

PRODUCT : CAMERA MODULE

MODEL NO. : CM8063-A130BF-E

SUPPLIER : TRULY SEMICONDUCTORS LTD.

DATE : November 8, 2007



CERT. No. 946535

ISO9001

TL9000

SPECIFICATION

Revision: 1.0

CM8063-A130BF-E

If there is no special request from customer, TRULY SEMICONDUCTORS Co., Ltd will not reserve the tooling of the product under the following conditions:

1. There is no response from customer in two years after TRULY SEMICONDUCTORS Co., Ltd submit the samples;

2. There is no order in two years after the latest mass production.

And correlated data (include quality record) will be reserved one year more after tooling was discarded.

TRULY SEMICONDUCTORS LTD:

CUSTOMER:

Quality Assurance Department: _____

Approved by:

Technical Department: _____

Approved by:

CONTENTS

- n KEY INFORMATION
- n PIN ASSIGNMENT
- n ELECTRICAL CHARACTERISTICS
- n MECHANICAL DRAWING
- n APPEARANCE SPECIFICATION
- n IMAGE SPECIFICATION
- n QA PLAN
- n PACKAGE SPECIFICATION
- n PRIOR CONSULT MATTER
- n FACTORY CONTACT INFORMATION

WRITTEN BY	CHECKED BY	APPROVED BY
LI JING	YAN SI ZHI	LIU TIE NAN

Key Information

Module No.		CM8063-A130BF-E
Module Size		8.0mm x 8.0mm x 4.50mm
Image Quality		≥500 TV line
Sensor Type		S5K5AAFx
Array Size		1280 X 1024(SXGA)
Power supply	Core	1.8V
	Analog	2.8V
	I/O	2.8V
Lens		1/5 inch 3Plastic+IR
Focus(F.NO)		2.8
View Angle		67°
Object distance		50cm-infinity
Frame rate		19fps@SXGA
Pixel size		2.8μm x 2.8μm
IR Cutter		650+/-10nm
Color filter		RGB Bayer Pattern
Sensor Temperature Range	Operation	-20° C to 60° C
	Storage	-40° C to 85° C
Output Formats	Parallel	.CIS Raw Data
Image scaling		SXGA,VGA,QVGA,QQVGA,CIF,QCIF And Any-size scaling down under SXGA
Maximum Pixel(data output) clock		60MHz
ADC resolution		10-Bit
IC Package		COB
Substrate		FPC

Pin Assignment

No.	Name	Pin type	Description
1	NC		
2	AGND	Power	Analog Ground
3	SIOD	I/O	I2C Serial Data
4	AVDD	Power	2.8V Supply Voltage
5	SIOC	Input	I2C Serial Clock
6	RESET	Input	Master Reset
7	VSYNC	Output	Vertical sync
8	PWDN	Power	Regulator Power Down (Open in Internal Regulator operation mode, IF Not using Internal Regulator tie to VDDA)
9	HREF	Output	Horizontal Sync
10	DVDD	Power	1.8V Supply Voltage
11	DOVDD	Power	2.8V Supply Voltage
12	Y9	Output	Pixel Data [9]
13	XCLK	Output	Master clock
14	Y8	Output	Pixel Data [8]
15	GND	Power	Ground
16	Y7	Output	Pixel Data [7]
17	PCLK	Output	Pixel Clock
18	Y6	Output	Pixel Data [6]
19	Y2	Output	Pixel Data [2]
20	Y5	Output	Pixel Data [5]
21	Y3	Output	Pixel Data [3]
22	Y4	Output	Pixel Data [4]
23	Y1	Output	Pixel Data [1]
24	Y0	Output	Pixel Data [0]

Electrical Characteristics

1. Absolute Maximum Ratings

Characteristics	Symbol	Value	Unit
I/O Digital Power (2.8V or 1.8V)	$V_{DDIO1}^{(1)}$	-0.3 to 3.8	V
	$V_{DDIO2}^{(2)}$	-0.3 to 2.5	
Analog Power (2.8V)	V_{DD28_CIS}	-0.3 to 3.8	
Regulator Power (1.8V)	$V_{DD18_REG}^{(3)}$	-0.3 to 2.5	
Core Digital Power (1.5V)	$V_{DD15}^{(4)}$	-0.3 to 2.0	
Input Voltage	V_{IN}	-0.3 to 3.8	
Operating Temperature	V_{OPR}	-20 to +60	°C
Storage Temperature	V_{STG}	-40 to +85	

[NOTE]

(1) 2.8V I/O Power Applied to VDDIO pins

(2) 1.8V I/O Power Applied to VDDIO pins

(3) 1.8V Regulator Power Applied to VDD18_REG pins

(4) Internal Regulator is not used and 1.5V Digital Power Applied to VDD15 pins directly

2 DC Characteristics

($V_{DDH} = 2.8V \pm 0.25V$, $V_{DDL} = 1.5V \pm 0.1V$, $T_a = -20$ to $+60$ °C)

Characteristics	Symbol	Condition	Min	Typ	Max	Unit
Operating voltage	V_{DD28_CIS}	Applied to VDD28_CIS	2.55	2.8	3.05	V
	V_{DD18_REG}	Applied to VDD18_REG	1.65	1.8	1.95	
	V_{DD15}	Applied to VDD15	1.40	1.5	1.60	
	V_{DDIO1}	Applied to VDDIO	2.55	2.8	3.05	
	V_{DDIO2}	Applied to VDDIO	1.65	1.8	1.95	
Input voltage ⁽¹⁾	V_{IH}	-	$0.7 \cdot V_{DDIO}$	-	-	
	V_{IL}	-	-	-	$0.2 \cdot V_{DDIO}$	
Input leakage current ⁽²⁾	I_{IL}	$V_{IN} = V_{DDH}$ to V_{SS}	-10	-	10	uA
Input leakage current with pull-down ⁽³⁾	I_{ILD}	$V_{IN} = V_{DDH}$	-	-	72	
Input leakage current with pull-up ⁽⁴⁾	I_{ILU}	$V_{IN} = V_{SS}$	-72	-	-	

High level output voltage	V_{OH}	$I_{OH} = -100\mu A^{(4)(5)}$	$V_{DDIO}-0.2$	-	-	V	
		$I_{OH} = -4mA^{(4)}$ $I_{OH} = -2,-4,-6,-8mA^{(5)}$	$0.7*V_{DDIO}$				
Low level output voltage	V_{OL}	$I_{OL} = 100\mu A^{(4)(5)}$	-	-	0.2		
		$I_{OL} = 4mA^{(4)}$ $I_{OL} = 2,4,6,8mA^{(5)}$			$0.3*V_{DDIO}$		
High-Z output leakage current (6)	I_{OZ}	$V_{OUT} = V_{SS}$ or V_{DDH}	-10	-	10		μA
Input capacitance(1)	C_{IN}	-	-	-	4		pF
Supply current	I_{STB}	STBYN=Low(Active) All input clocks = Low 0 lux illumination	-	30	120	μA	
	I_{DD}	$f_{MCLK} = 27MHz$	-	100	130	mA	
Operation Power Consumption	P_{OP}	-	-	200	250	mW	

[NOTE]

(1) Applied to STBYN, FLASH, SCE, TST, MCLK, RSTN, CLKSEL, SCL, SDA pins

(2) Applied to STBYN, MCLK, RSTN, CLKSEL, SCL, SDA pins

(3) Applied to FLASH, SCE, TST pins

(4) Applied to HSYNC, VSYNC pins

(5) Applied to SCL, SDA, PCLK, D0 to D9 pins

(6) Applied to SCL, SDA pins when in High-Z output state

Applied to HSYNC, VSYNC, PCLK, D0 to D9 pins when in Stand-by Mode

3 AC Characteristics

Characteristic		Symbol	Condition	Min	Typ	Max	Unit
Main input clock frequency	Using PLL	f_{MCLK}	Duty = 50%	13.5	-	40	MHz
	Not using PLL	f_{MCLK}	Duty = 50%	13.5	-	60	MHz
Data output clock frequency		f_{PCLK}	-	13.5	-	60	MHz
Using PLL	Data Setup Time	T1	D[7:0] output	2.9	-	6.1	ns
	Hsync Setup Time	T2	HSYNC output	3.2	-	6.4	ns
	Vsync Setup Time	T3	VSYNC output	3.4	-	6.7	ns
	Data Hold Time	T4	D[7:0] output	8.5	-	14.0	ns
	Hsync Hold Time	T5	HSYNC output	8.7	-	13.5	ns
	Vsync Hold Time	T6	VSYNC output	9.1	-	14.2	ns
Not Using PLL	Data Setup Time	T1	D[7:0] output	5.4	-	9.1	ns
	Hsync Setup Time	T2	HSYNC output	6.2	-	9.3	ns
	Vsync Setup Time	T3	VSYNC output	6.7	-	9.5	ns
	Data Hold Time	T4	D[7:0] output	7.3	-	12.0	ns
	Hsync Hold Time	T5	HSYNC output	7.7	-	11.5	ns
	Vsync Hold Time	T6	VSYNC output	8.0	-	12.2	ns

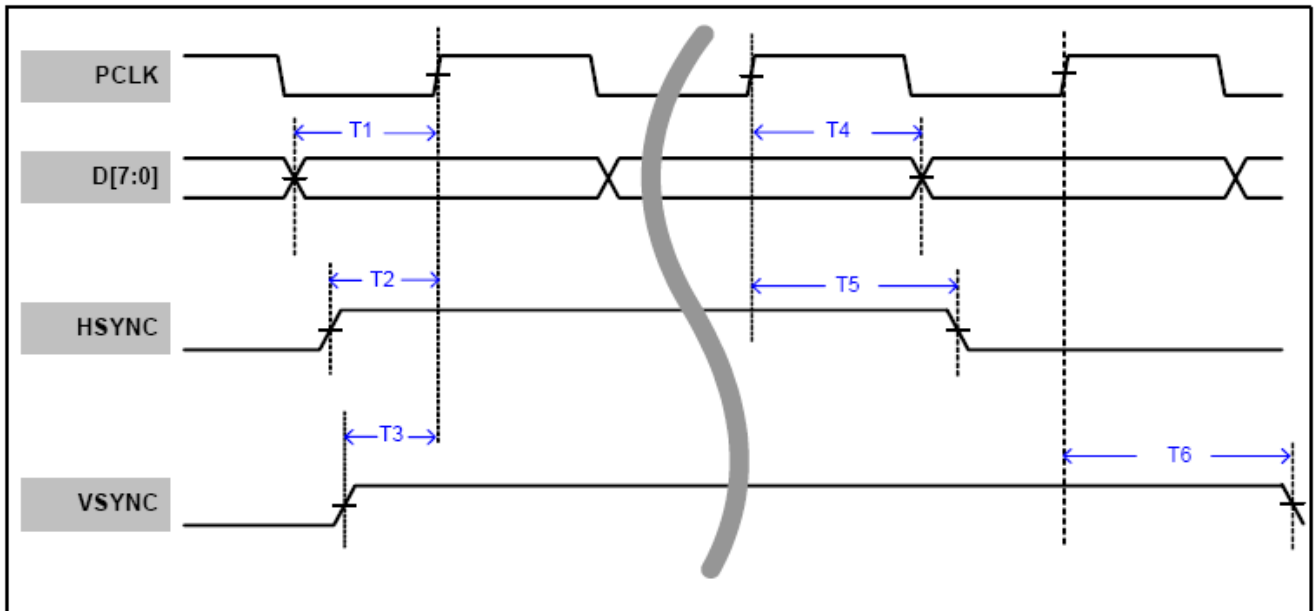

[NOTE]

(1) T1~T6 at PCLK(50MHz)=6mA, Data=6mA, Sync=4mA, External Cap=10pF

Note: For more information of sensor please refer to the S5K5AAFx specification.

Appearance Specification

NO.	Item	Standard	Importance Class
1	Top side of Lens	No obvious impurity and oil impurity on the front of lens within the half area; The defect(unfeeling) limitation: width \leq 1mm, length \leq 2mm, the defect number \leq 2; No feeling defect; The width of defects and gaps on the outside of Lens \leq 0.3mm. Others are unlimited.	A
2	Screw glue	Normally screw glue shall be symmetrical distributed around lens circle side. Particular circs, glue distribution must not disturb customer's assembly operation.	A
3	L1 Glass	No defect and dust check from 45° angle under the reflexing light and from 0° under the highlight	A
4	Holder	No obvious impurity and distortion of outline. The width and length of defect is unlimited, the depth \leq 0.1mm and \leq 1/4 of the thickness of Holder.	B
5	Sealed glue	Sealed glue distributing between holder and FPC must be symmetrical and smooth. Not allow glue leakage and asymmetric thickness. After holder assembly, the thickness distance between one side and its opposite side shall be less than 0.2mm. Excess glue over the holder shall not make the outside dimension be out of control.	A
6	FPC/PCB	Edge defect limitation: width \leq 1/2H (H is minimum.)、 length \leq 1mm、 defect numbers per edge \leq 2(No tearing gap inby edge for FPC); Edge outshoot limitation (width \leq 0.3mm, length \leq 1mm). No obvious impurity and crease on the surface. If there was shield film on the surface, the spot size of the film shall be less than 0.3mm \times 1mm and no line is exposed. If it was not be cleaned and did not influence the total thickness, it would be permitted. Label and mark shall be clear enough to be discerned.	A
7	Connector	No dust, fingerprint, and not allows to turning colors, distortion; Solder must be well; No open circuit or short circuit	A

8	Gold finger	No dust, fingerprint, and not allows to turning colors, burned, unsmoothed and peeled; No open circuit or short circuit; The defect width shall be smaller than 20% of gold finger's width. No copper/nickel exposed in defect. Numbers of defected pin shall be less than 3. The defect limitation:width \leq 0.08mm,length \leq 5mm.	A
9	Stiffener	Holder anchor pole length overtopping the steel plate shall be less than 0.2mm. No dust, rust and deep scratch on the steel surface without Double coated tapes.	B
10	Double coated tapes	Adhered direction shall be right. Not allows to excess steel plate edge. No alveoli and stick. Not allows to peel glue and rip protective paper when tear the protective paper.	B
11	Protective film	No dust in the glue side. Not allows to float or drop. Adhered direction shall be right.	B

Remark:

1. The definition of the appearance importance class

- A: The defect can be found in the finished product, or have obvious visual differences from good products, such as crack, defect and dust, or influence image quality, or are appointed by the customer. We will emphasize these items and check all products.
- B: The defect can be found in the finished product and has visual difference from the good one, but will not affect customer's aesthetic judgement. Or the defect can not be found in the finished product and will not generate functional problem, but will slightly influence sequential manufacture process or condition. We will supervise these items in the manufacturing process and check products selectively.

2. Sampling standard

Referenced standard: GB/T 2828.1-2003/ISO 2859-1:1999 and ANSI/ASQC.4-1993 II

Image Specification

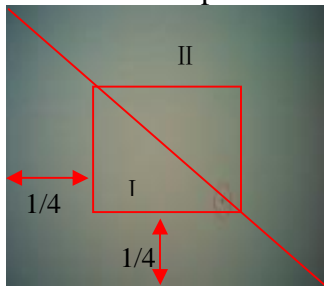
NO.	Item	Standard	Important Class
1	TV Line	Center \geq 650 8 point of 0.7 viewing field \geq 500	A
2	Shading	The lightness of 90% viewing area \geq 40% of center lightness(Lens correction Shading [Turn off]); The lightness of 90% viewing area \geq 60% of center lightness(Lens correction Shading [Turn on])	A
3	Dust	No dust in the center viewing area; Border area according to the limit samples	A
4	Dead pixel	No in the viewing area.	A
5	Wound pixel 	I area: Blemish number \leq 1 II area: Blemish number \leq 4	B
6	Color	Color distortion ratio of center \pm 15%	B
7	Gray Scale	Margin of two near scales' brightness \geq 6	B
8	Distortion	$<$ 1%	B
9	Flare	No flare in 45° viewing angle; No ghost in full viewing angle	B

QA Plan

NO.	Item	Sampling frequency	Measure	Remark
Image and reliability item				
1	TV Line	AQL 0.65 II Class	Same as production	100% Inspection
2	Shading	AQL 0.65 II Class	Same as production	100% Inspection
3	Dust	AQL 0.65 II Class	Same as production	100% Inspection
4	Dead pixel	AQL 0.65 II Class	Same as production	100% Inspection
5	Wound pixel	AQL 1.5 II Class	Same as production	100% Inspection
6	Color	AQL 1.5 II Class	Same as production	100% Inspection
7	Gray Scale	AQL 1.5 II Class	Same as production	100% Inspection
8	Distortion	N=5,c=0 per batch	Same as production	Sampling by QA
9	Flare	N=5,c=0 per batch	Same as production	Sampling by QA
Appearance Check Items				
1	Top side of Lens	AQL 1.0 II Class	Same as production	100% Inspection
2	Screw glue	AQL 1.0 II Class	Same as production	100% Inspection
3	L1 Glass	AQL 1.0 II Class	Same as production	100% Inspection
4	Holder	AQL 1.5 II Class	Same as production	100% Inspection
5	Sealed glue	AQL 1.0 II Class	Same as production	100% Inspection
6	FPC/PCB	AQL 1.0 II Class	Same as production	100% Inspection
7	Connector	AQL 1.0 II Class	Same as production	100% Inspection
8	Gold finger	AQL 1.0 II Class	Same as production	100% Inspection
9	Stiffener	AQL 1.5 II Class	Same as production	100% Inspection
10	Double coated tapes	AQL 1.5 II Class	Same as production	100% Inspection
11	Protective film	AQL 1.5 II Class	Same as production	100% Inspection

Sample:

Referenced standard: GB/T 2828.1-2003/ISO 2859-1:1999 and ANSI/ASQC.4-1993 II

Package Specification

Packaging Design One

Product No.	CM8063-A130BF-E	Release date									
Product name	Compact Camera Module	Releaser									
Supplier	TRULY SEMI CONDUCTORS LTD	Recycle	<input type="checkbox"/> YES <input checked="" type="checkbox"/> NO								
Quantity/ each box	TBD	Material for box	<input checked="" type="checkbox"/> paper <input type="checkbox"/> plastic								
Outer carton box size	405mm*290mm*290mm	Box type	<input checked="" type="checkbox"/> new <input type="checkbox"/> update								
Quantity / inner box * Quantity / outer box	TBD	Weight	<table border="1"> <tr> <td></td> <td>g / pcs</td> <td>BOX=TYPE Record of SRF Dept.</td> <td>TBD</td> </tr> <tr> <td></td> <td>Kg / outer box</td> <td></td> <td>Kg(Max)</td> </tr> </table>		g / pcs	BOX=TYPE Record of SRF Dept.	TBD		Kg / outer box		Kg(Max)
	g / pcs	BOX=TYPE Record of SRF Dept.	TBD								
	Kg / outer box		Kg(Max)								

Packing Standards:

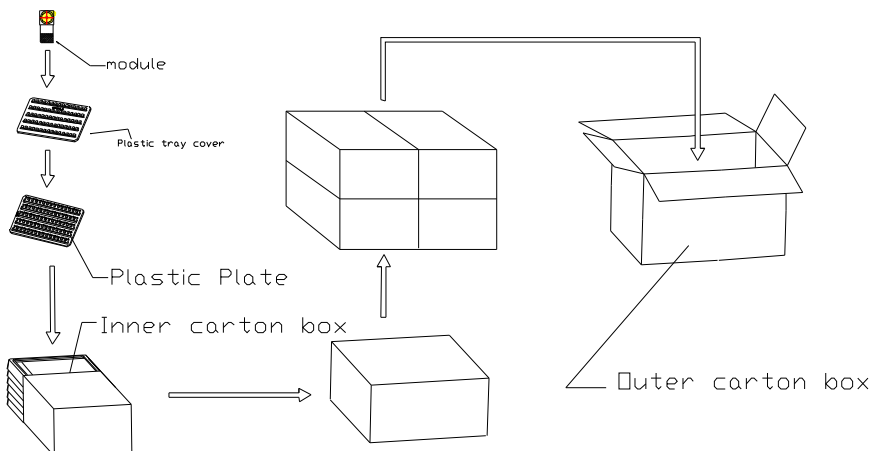

There are TBD modules each plastic plate.

There are TBD modules each inner carton box..

There are 4 each outer carton box.

Requirements of outer carton box :

1. Weight(Max): TBD Kg
2. Height (Max): 0.29 M
3. Prohibition: Box made by log

Material for Plastic tray

It is made of antistatic polystyrene which has no chemical pollution. Surface resistivity : 10^6 ohm/sq

Packaging Design Two

Product No.	CM8063-A130BF-E	Release date							
Product name	Compact Camera Module	Releaser							
Supplier	TRULY SEMI CONDUCTORS LTD	Recycle	<input type="checkbox"/> YES <input checked="" type="checkbox"/> NO						
Quantity/ each box	TBD	Material for box	<input checked="" type="checkbox"/> paper <input type="checkbox"/> plastic						
Outer carton box size	405 mm *280 mm *170 mm	Box type	<input checked="" type="checkbox"/> new <input type="checkbox"/> update						
Quantity / inner box * Quantity / outer box	TBD	Weight	<table border="1"> <tr> <td>g / pcs</td> <td>BOX=TYPE Record of SRF Dept.</td> <td>TBD</td> </tr> <tr> <td>Kg / outer box</td> <td></td> <td>Kg(Max)</td> </tr> </table>	g / pcs	BOX=TYPE Record of SRF Dept.	TBD	Kg / outer box		Kg(Max)
g / pcs	BOX=TYPE Record of SRF Dept.	TBD							
Kg / outer box		Kg(Max)							

Packing Standards:

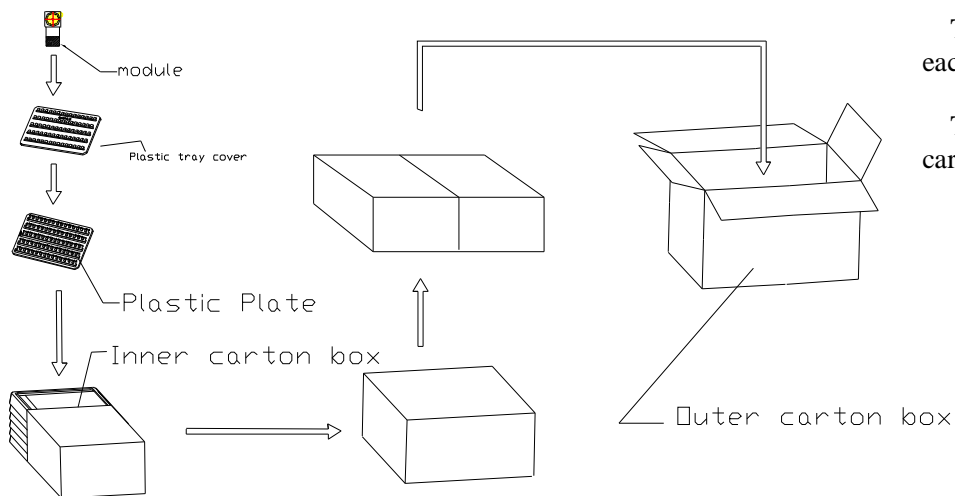

There are TBD modules each plastic plate.

There are TBD modules each inner carton box..

There are 2 each outer carton box.

Requirements of outer carton box :

4. Weight(Max): TBD Kg
5. Height (Max): 0.17 M
6. Prohibition: Box made by log

Material for Plastic tray

It is made of antistatic polystyrene which has no chemical pollution. Surface resistivity : 10^6 ohm/sq

PRIOR CONSULT MATTER

- 1.①For Truly standard products, we keep the right to change material, process for improving the product property without notice on our customer.
②For OEM products, if any change needed which may affect the product property, we will consult with our customer in advance.
2. If you have special requirement about reliability condition, please let us know before you start the test on our samples.

FACTORY CONTACT INFORMATION

FACTORY NAME: TRULY SEMICONDUCTORS LTD.

FACTORY ADDRESS: Truly Industrial Area, ShanWei City, GuangDong, China

FACTORY PHONE: 86-0660-3380061 **FAX:** 86-0660-3371772