

**PRODUCT** : CAMERA MODULE**MODEL NO.** : CM1360-A200SF-E**SUPPLIER** : TRULY SEMICONDUCTORS LTD.**DATE** : April 19, 2007

CERT. No. 946535  
 ISO9001  
 TL9000

# SPECIFICATION

Revision: 0.4

**CM1360-A200SF-E**

preliminary

If there is no special request from customer, TRULY SEMICONDUCTORS Co., Ltd will not reserve the tooling of the product under the following conditions:

1. There is no response from customer in two years after TRULY SEMICONDUCTORS Co., Ltd submit the samples;
2. There is no order in two years after the latest mass production.

And correlated data (include quality record) will be reserved one year more after tooling was discarded.

**TRULY SEMICONDUCTORS LTD:**

**CUSTOMER:**

Quality Assurance Department: \_\_\_\_\_

Approved by:

Technical Department: \_\_\_\_\_

Approved by:



# CONTENTS

- n KEY INFORMATION
- n PIN ASSIGNMENT
- n ELECTRICAL CHARACTERISTICS
- n MECHANICAL DRAWING
- n APPEARANCE SPECIFICATION
- n IMAGE SPECIFICATION
- n QA PLAN
- n RELIABILITY SPECIFICATION
- n PACKAGE SPECIFICATION
- n PRIOR CONSULT MATTER
- n FACTORY CONTACT INFORMATION

WRITTEN BY	CHECKED BY	APPROVED BY
HUANG LI LING	LIU TIE NAN	HUANG YU XIN

**Key Information**

<b>Module No.</b>		<b>CM1360-A200SF-E</b>
Module Size		8.0mm x 8.0mm x 5.15mm
Image Quality		≥600 TV line
Sensor Type		OV2640
Array Size	UXGA	1600 X 1200
Power supply	core	1.3VDC +/-5%
	Analog	2.5~3.0 VDC
	I/O	1.7V to 3.3V
Lens		1/4 inch 3Plastic+ IR
Focus(F.NO)		2.8
View Angle		66.2°
Image Area		3590μm x 2684μm
Object distance		80cm-infinity
sensitivity		0.6V/Lux-sec
Pixel size		2.2μm x 2.2μm
IR Cutter		650+/-10nm
Operating Temperature		0° C to 50° C
Output Formats(8-bit)		YUV(422/420)/YCbCr422 RGB565/555 8-bit compressed data 8-/10-bit Raw RGB Data
Maximum Image Transfer Rate	UXGA	15 fps
	SVGA	30 fps
	CIF	60 fps
S/N Rate		40dB
Dynamic Range		50dB
substrate		FPC
IC Package		CSP-38PIN
Power requirement	Active	125mW(for 15fps, UXGA YUV mode) 140mW(for 15fps,UXGA compressed mode)
	Standby	TBD
Fixed Pattern noise		<1% of Vpeak-to-peak
Scan Mode		Progressive
Dark current		15mV/s at 60°C
Package		Antistatic Plastic

## Pin Assignment

No.	Name	Pin type	Description
1	NC		
2	AGND	Ground	Analog Ground
3	SIO_D	I/O	SCCB serial interface data I/O
4	AVDD	Power	Analog power supply
5	SIO_C	Input	SCCB serial interface clock input
6	RESET	Input	Reset mode, active low Note: There is no internal pull-up/pull-down resistor.
7	VSYNC	I/O	Vertical sync output Default: Input
8	PWDN	Input	Power Down Mode Enable, active high Note: There is an internal pull-down resistor.
9	HREF	I/O	HREF output Default: Input
10	DVDD	Power	Sensor digital power (Core)
11	DOVDD	Power	Power for digital video port
12	Y9	I/O	Video port output bit[9] Default: Input
13	XVCLK1	Input	System clock input Note: There is no internal pull-up/pull-down resistor
14	Y8	I/O	Video port output bit[8] Default: Input
15	GND	Ground	Ground
16	Y7	I/O	Video port output bit[7] Default: Input
17	PCLK	I/O	Pixel clock output Default: Input
18	Y6	I/O	Video port output bit[6] Default: Input
19	Y2	I/O	Video port output bit[2] Default: Input
20	Y5	I/O	Video port output bit[5] Default: Input
21	Y3	I/O	Video port output bit[3] Default: Input
22	Y4	I/O	Video port output bit[4] Default: Input
23	Y1	I/O	Video port output bit[1] Default: Input
24	Y0	I/O	Video port output bit[0] Default: Input

## Electrical Characteristics

### 1. Absolute Maximum Ratings

<b>Ambient Storage Temperature</b>		-40°C to +95°C
<b>Supply Voltages (with respect to Ground)</b>	<b>V<sub>DD-A</sub></b>	4.5V
	<b>V<sub>DD-C</sub></b>	3V
	<b>V<sub>DD-IO</sub></b>	4.5V
<b>All Input/Output Voltages (with respect to Ground)</b>		-0.3V to V <sub>DD-IO</sub> +1V
<b>Lead-free Temperature, Surface-mount process</b>		245°C

**NOTE:** Exceeding the Absolute Maximum ratings shown above invalidates all AC and DC electrical specifications and may result in permanent device damage.

### 2. DC Characteristics (-30°C < Ta < 70°C)

Symbol	Parameter	Min	Typ	Max	Unit
<b>Supply</b>					
V <sub>DD-A</sub>	Supply voltage	2.5 <sup>a</sup>	2.8	3.0	V
V <sub>DD-D</sub>	Supply voltage	1.24	1.3	1.36	V
V <sub>DD-IO</sub>	Supply voltage <sup>b</sup>	1.71	2.8	3.3	V
I <sub>DDA-A</sub>	Active (Operating) Current <sup>c</sup>		30	40	mA
I <sub>DDA-D</sub>	Active (Operating) Current <sup>c</sup>		30 (YUV) 45 (Compressed)	40 (YUV) 60 (Compressed)	mA
I <sub>DDA-IO</sub>	Active (Operating) Current <sup>c</sup>		6	15	mA
I <sub>DDS-SCCB</sub>	Standby Current <sup>d</sup>		1	2	mA
I <sub>DDS-PWDN</sub>			600	1200	μA
<b>Digital Inputs</b>					
V <sub>IL</sub>	Input voltage LOW			0.54	V
V <sub>IH</sub>	Input voltage HIGH	1.26			V
C <sub>IN</sub>	Input capacitor			10	pF
<b>Digital Outputs (standard loading 25 pF)</b>					
V <sub>OH</sub>	Output voltage HIGH	1.62			V
V <sub>OL</sub>	Output voltage LOW			0.18	V
<b>Serial Interface Inputs</b>					
V <sub>IL</sub>	SIO_C and SIO_D	-0.5	0	0.54	V
V <sub>IH</sub>	SIO_C and SIO_D	1.26	1.8	2.3	V

a. If using internal regulator for DVDD, V<sub>DD-A</sub> requires greater than or equal to 2.65V

b. 1.8V I/O is supported. Contact your local OmniVision FAE for further details.

c. V<sub>DD-A</sub> = 2.8V, V<sub>DD-D</sub> = 1.3V, and V<sub>DD-IO</sub> = 1.8V for 15 fps in UXGA mode

d. I<sub>DDS-SCCB</sub> refers to SCCB-initiated Standby, while I<sub>DDS-PWDN</sub> refers to PWDN pad-initiated Standby

3. AC Characteristics ( $T_A=25^{\circ}\text{C}$ ,  $V_{DD-A}=2.8\text{V}^{\circ}\text{C}$ )

Symbol	Parameter	Min	Typ	Max	Unit
<b>ADC Parameters</b>					
B	Analog bandwidth		20		MHz
DLE	DC differential linearity error		0.5		LSB
ILE	DC integral linearity error		1		LSB
	Settling time for hardware reset			<1	ms
	Settling time for software reset			<1	ms
	Settling time for UXGA/SVGA mode change			<1	ms
	Settling time for register setting			<300	ms

## 4. Timing Characteristics

Symbol	Parameter	Min	Typ	Max	Unit
<b>Oscillator and Clock Input</b>					
$f_{\text{OSC}}$	Frequency (XVCLK)	6	24		MHz
$t_r, t_f$	Clock input rise/fall time			5	ns
	Clock input duty cycle	45	50	55	%

**Note:** For more information of sensor please refer to the OV2640 specification.

# ROHS

## CM1360-A200SF-E Camera Module

Customer No.:

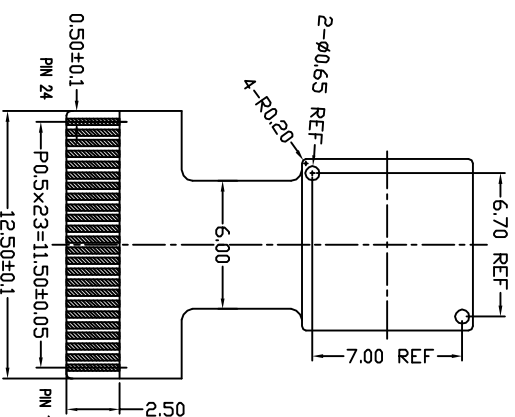
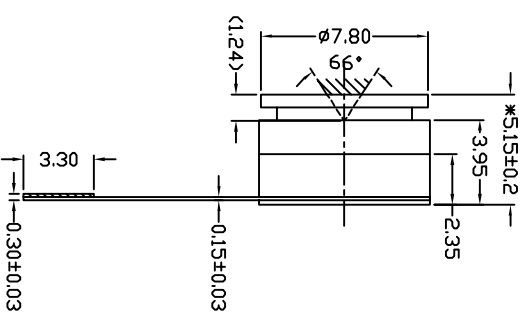
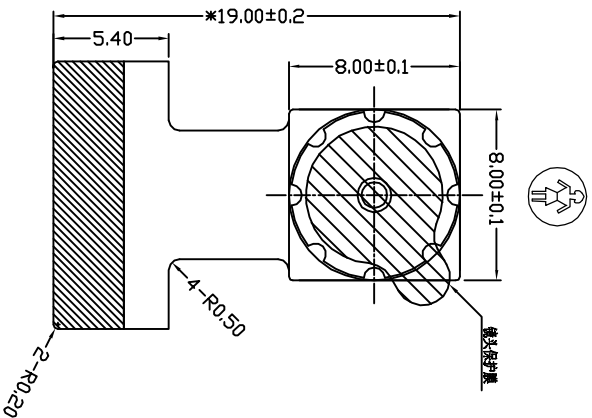

### 24PIN DESCRIPTION

NO.	SIGNAL	NO.	SIGNAL
1	NC	24	Y0
2	AGND	23	Y1
3	SIO_D	22	Y4
4	AVDD(2.8V)	21	Y3
5	SIO_C	20	Y5
6	RESET	19	Y2
7	VSYNC	18	Y6
8	PWDN	17	PCLK
9	HREF	16	Y7
10	DVDD(1.3V)	15	GND
11	DOVDD	14	Y8
12	Y9	13	XVCLK1

DVDD(1.3V+/-5%)  
AVDD(2.5~3.0V)  
DOVDD(1.7~3.3V)

### 主要参数 (Module Specification)

焦距 (FPL)	3.6 mm
光圈 (F.NO)	2.8
视场角 (View Angle)	66.2°
畸变 (Distortion)	< 1 %
解象力 (Image Quality)	≥ 600 TV Line
景深 (Focusing Range)	80 cm~Infinity
感光芯片 (Chip Type)	OV2640
像素 (Array Size)	2.0M
镜头类型 (Lens Size)	1/4 INCH 3P+1R

### CUSTOMER APPROVE

Mechanical Electrical

### AMEND

NO. NAME QTY Part No. VENDOR

### 光电感应模组

TOLERANCE :  
DECIMAL  
.x ± .30  
.xx ± .20  
∠ ± 1/4

### TRULY SEMICONDUCTORS LTD.

PRODUCT NO. DRAW NO. REV  
CM1360-A200SF-E D D

NO.	CONTENT	DATE
1	修正镜头参数	20070419
2	修改HOLDER位置	20070226
3	更换镜头	20060929

CHKD	VIND	WANG	20070419	APPD	黄育新	20070419
NDT IN SCALE UNIT mm SHEET: 1/1						

### Appearance Specification

NO.	Item	Standard	Importanc e Class	Designated sample	Method/ Tool
1	Outline	Checked according to product dimension and tolerance spec	A	No	Vernier ,C hecking tool
2	Appearance cleanness and defect	No impurity and oil impurity [Non-glass area]	B	Yes	Fluoresce nt lamp or appointed light source
3	Glass clearness and defect	No defect and dust check from 45° angle under the reflexing light and from 0° under the highlight	A	No	Fluoresce nt lamp
4	Screw glue	Glue homogeneous distributing around lens circle side .Not allows to excess glue over the height of Lens and Holder outside.	A	No	Fluoresce nt lamp
5	Sealed glue	Glue distributing between holder and FPC must be homogeneous and smooth. Not allows to excess glue over the width of holder.	A	Yes	Fluoresce nt lamp
6	FPC impurity	No obvious impurity on the surface	B	Yes	Fluoresce nt lamp
7	FPC label or mark	Recognizable and Clear	C	Yes	Fluoresce nt lamp
8	FPC edge	Edge outshoot limitation (width≤0.3mm,length≤1mm)	B	No	Fluoresce nt lamp
9	FPC defect	Edge defect limitation: width≤1/2H(H is minimum.)、 length≤1mm、 defect numbers per edge≤2(no tearing gap inby edge)	A	No	Fluoresce nt lamp
10	FPC shield [FPC with silver or silver-platinum coverfilm]	Surface shield pastern must cover the whole silver or silver-platinum area. No exposed copper line	B	No	Fluoresce nt lamp
11	Gold finger appearance	No dust, fingerprint, and not allows to turning colors, burned, unsmoothed and peeled. No open circuit or short circuit	A	Yes	Fluoresce nt lamp

12	Gold finger defect	The defect width shall be smaller than 20% of gold finger's width. No copper/nickel exposed in defect. Numbers of defected pin shall be less than 3. The defect limitation: width $\leq$ 0.08mm, length $\leq$ 5mm.	B	No	Fluorescent lamp
13	Stiffener	Holder anchor pole length overtopping the steel plate shall be less than 0.3mm. No dust, rust and deep scratch on the steel surface without Double coated tapes.	C	Yes	Fluorescent lamp
14	Double coated tapes	Adhered direction shall be right. Not allows to excess steel plate edge. No alveoli and stick. Not allows to peel glue and rip protective paper when tear the protective paper.	B	No	Fluorescent lamp
15	Protective film	No dust in the glue side. Not allows to float or drop.	B	No	Fluorescent lamp

Remark:

1. The definition of the appearance importance class

- A: The defect can be found in the finished product, or have obvious visual differences from good products, such as crack, defect and dust, or influence image quality, or are appointed by the customer. We will emphasize these items and check all products.
- B: The defect can be found in the finished product and has visual difference from the good one, but will not affect customer's aesthetic judgement. Or the defect can not be found in the finished product and will not generate functional problem, but will slightly influence sequential manufacture process or condition. We will supervise these items in the manufacturing process and check products selectively.
- C: The defect can not be found in the finished product. It has no any effect on the product quality but a little difference from others of the same terms. We will supervise these items and check products selectively.

2. Sampling standard

Referenced standard: GB/T 2828.1 (SAMPLING PROCEDURES AND TABLES FOR INSPECTION BY ATTRIBUTES (REFER TO GB/T 2828.1))

Exterior standards: Class II

**Image Specification**

NO.	Item	Standard	Important level	Sample limit	Tool	Inspecting Method	Inspection numbers
1	Product height	5.15mm +/- 0.2 (Without protective film )	A	No	Tool of inspecting height	Pass tool of inspecting height	100% Inspection
2	TV Line	≥600	A	No	Testing machine	Inspecting Automatically by machine	100% Inspection
3	Shading	The lightness of 90% viewing area must reach 45% of center lightness .The size of sampling area is 40×40 pixels.(Shading correction function of sensor disabled)	A	No	Testing machine	Inspecting Automatically by machine	100% Inspection
4	Dust	No dust in the viewing area.	A	No	Testing machine	Inspecting Automatically by machine	100% Inspection
5	Dead & Wound (size ≤4 ×4 pixels)	0.3Mega Module A area: Blemish number ≤2 B area: Blemish number ≤4 1.3Mega module and upwards A area: Blemish number ≤1 B area: Blemish number ≤2	A	No	Testing machine	Inspecting Automatically by machine	100% Inspection
6	Color	Color distortion ratio <20%	A	No	Testing machine	Inspecting Automatically by machine	100% Inspection
7	Gray Scale	Margin of two near scales' brightness >8	A	No	Testing machine	Inspecting Automatically by machine	100% Inspection
8	Screw torsion measure	1. Lens φ ≤6, no less than 0.5Kgf.cm 2. Others no less than 1Kgf.cm	A	No	Torsional dynamometer	Apparatus display	Sampling by QA

9	Thrust test	No less than 2kgf	A	No	Thrust dynamometer	Apparatus display	Sampling by QA
10	Wearing test	Inspecting selective samples with all above items after reliability testing was finished.	A	No	AF-600/ Tool of inspecting height/ Torsional dynamometer	Eyeballing	100% inspecting in Sample term. Selective inspecting in mass production term.

## QA Plan

NO.	Item	Sampling frequency	Measure	Remark
Image and reliability item				
1	Product height	0.65 II Class	Same as production	100% Inspection
2	TV Line	0.65 II Class	Same as production	100% Inspection
3	Shading	0.65 II Class	Same as production	100% Inspection
4	Dust	0.65 II Class	Same as production	100% Inspection
5	Dead & Wound pixel	0.65 II Class	Same as production	100% Inspection
6	Color	0.65 II Class	Same as production	100% Inspection
7	Gray Scale	0.65 II Class	Same as production	100% Inspection
8	TV Distortion	N=5,c=0 per batch	Same as production	Sampling by QA
9	Flare	N=5,c=0 per batch	Same as production	Sampling by QA
10	Screw torsion	N=5,c=0 per batch	Special torsional dynamometer	Sampling by QA
11	Holder thrust	N=5,c=0 per batch	Special thrust dynamometer	Sampling by QA
12	Reliability test	N=5,c=0 per style of mass production on the first time	1. Use reliability testing instrument 2. Inspecting all items of QA plan after reliability test finished.	1. Test 1 time in Sample term. 2. Test along sampling frequency in mass production term.
Appearance Check Items				
1	External dimension	AQL 1.0 II Class	Same as production	100% Inspection
2	Appearance clear and defect	AQL 1.0 II Class	Same as production	100% Inspection
3	Glass clear and defect	AQL 1.0 II Class	Same as production	100% Inspection
4	Screw glue	AQL 1.0 II Class	Same as production	100% Inspection
5	Fluid sealant	AQL 1.0 II Class	Same as production	100% Inspection
6	FPC sully	AQL 1.0 II Class	Same as production	100% Inspection
7	FPC printing	AQL 1.0 II Class	Same as production	100% Inspection
8	FPC coarse	AQL 1.0 II Class	Same as production	100% Inspection
9	FPC defect	AQL 1.0 II Class	Same as production	100% Inspection

10	FPC shield	AQL 1.0 II Class	Same as production	100% Inspection (only for FPC with silver coverfilm)
11	Gold finger appearance	AQL 1.0 II Class	Same as production	100% Inspection
12	Gold defect	AQL 1.0 II Class	Same as production	100% Inspection
13	Stiffener	AQL 1.0 II Class	Same as production	100% Inspection
14	Double coated tapes	AQL 1.0 II Class	Same as production	100% Inspection
15	Protective film	AQL 1.0 II Class	Same as production	100% Inspection

Sample reference standard: GB/T 2828.1 (SAMPLING PROCEDURES AND TABLES FOR INSPECTION BY ATTRIBUTES (REFER TO GB/T 2828.1) )

**Reliability Specification**

No.	Test item	Test condition
1	Temperature strike cycle [Power off]	Low temperature:-30°C±2°C for 30 min High temperature:+80°C±2°C for 30 min Cycle:10 times
2	High temperature and high humidity operating	Temperature:40°C Humidity:90%RH Time:48 hours
3	High temperature and high humidity storage	Temperature:60°C Humidity:90%RH Time:120 hours
4	Low temperature operating	Temperature:-20°C±2°C Time:120 hours
5	High temperature operating	Temperature:70°C±2°C Time:120 hours
6	Low temperature storage	Temperature:-30°C±2°C Time:120 hours
7	High temperature storage	Temperature:80°C±2°C Time:120 hours
8	ESD test [Power off]	C:150pF R:330Ω Voltage:+/-2KV Air discharge: Cycle:10 times
9	Vibration Test [Packaged]	Frequency:10Hz~55Hz~10Hz Amplitude:1.5 mm Times: each X,Y,Z directions for 60mins
10	Dropping test [Packaged]	Product dropping from 150cm height to smooth marble Drop style:1 coner,3 arris,6 faces Test times:10

## Package Specification

### Packaging Design

Product No.	CM1360-A200SF-E	Release date	
Product name	Compact Camera Module	Releaser	
Supplier	TRULY SEMI CONDUCTORS LTD	Recycle	( )YES ( )NO
Quantity/ each box	TBD	Material for box	( ) paper ( ) plastic
Outer carton box size	TBD	Box type	( )new ( )update
Quantity / inner box * Quantity / outer box	TBD	Weight	BOX=TYPE Record of SRF Dept.      Kg(Max)

#### Packing Standards:

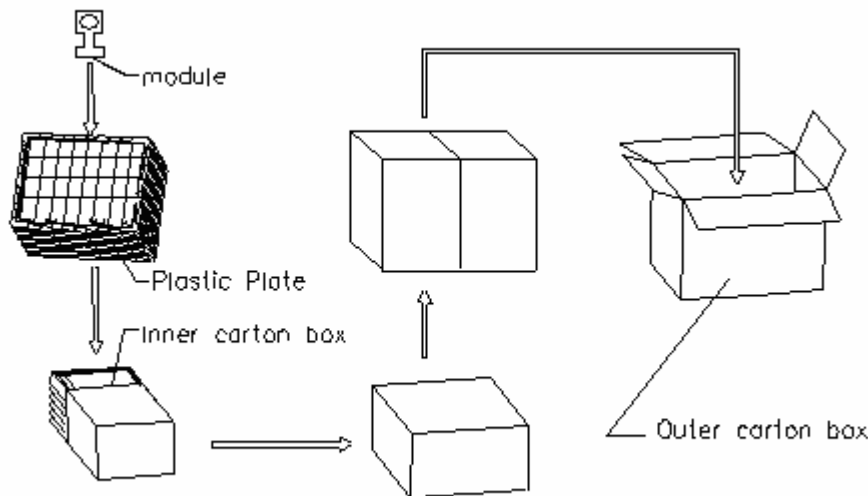

There are **TBD** modules each plastic plate.

There are **TBD** modules each inner carton box..

There are **TBD** inner carton boxes each outer carton box.

#### Requirements of outer carton box :

1. Weight(Max): **TBD** Kg
2. Height (Max): **TBD** M
3. Prohibition: Box made by log

#### Material for Plastic tray

It is made of antistatic polystyrene which has no chemical pollution. Surface resistivity :  $10^6$  ohm/sq

## **PRIOR CONSULT MATTER**

- 1.①For Truly standard products, we keep the right to change material, process for improving the product property without notice on our customer.  
②For OEM products, if any change needed which may affect the product property, we will consult with our customer in advance.
2. If you have special requirement about reliability condition, please let us know before you start the test on our samples.

## **FACTORY CONTACT INFORMATION**

**FACTORY NAME:** TRULY SEMICONDUCTORS LTD.

**FACTORY ADDRESS:** Truly Industrial Area, ShanWei City, GuangDong, China

**FACTORY PHONE:** 86-0660-3380061      **FAX:** 86-0660-3371772