

PRODUCT : CAMERA MODULE

MODEL NO. : CM8021-A200SM-E

SUPPLIER : TRULY SEMICONDUCTORS LTD.

DATE : September 24, 2007



CERT. No. 946535

ISO9001

TL9000

SPECIFICATION

Revision: 1.0

CM8021-A200SM-E

If there is no special request from customer, TRULY SEMICONDUCTORS Co., Ltd will not reserve the tooling of the product under the following conditions:

1. There is no response from customer in two years after TRULY SEMICONDUCTORS Co., Ltd submit the samples;

2. There is no order in two years after the latest mass production.

And correlated data (include quality record) will be reserved one year more after tooling was discarded.

TRULY SEMICONDUCTORS LTD:

CUSTOMER:

Quality Assurance Department: _____

Approved by:

Technical Department: _____

Approved by:

CONTENTS

- n KEY INFORMATION
- n PIN ASSIGNMENT
- n ELECTRICAL CHARACTERISTICS
- n MECHANICAL DRAWING
- n APPEARANCE SPECIFICATION
- n IMAGE SPECIFICATION
- n QA PLAN
- n PACKAGE SPECIFICATION
- n PRIOR CONSULT MATTER
- n FACTORY CONTACT INFORMATION

WRITTEN BY	CHECKED BY	APPROVED BY
LI JING	YAN SI ZHI	LIU TIE NAN

Key Information

Module No.		CM8021-A200SM-E
Module Size		9.0mm X 9.0mm X (5.50-5.75)mm
Image Quality		≥600 TV line
Sensor Type		OV2640
Array Size	UXGA	1600 X 1200
Power supply	core	1.3VDC +/-5%
	Analog	2.5~3.0 VDC
	I/O	1.7V to 3.3V
Lens		1/4 inch 3Plastic+ IR
Focus(F.NO)		2.8
View Angle		65°
Image Area		3590μm x 2684μm
Object distance		80cm-infinity(NORMAL) 7cm (MACRO)
Sensitivity		0.6V/Lux-sec
Pixel size		2.2μm x 2.2μm
IR Cutter		650+/-10nm
Sensor Operating Temperature	Stable Image	0° C to 50° C
Output Formats(8-bit)		YUV(422/420)/YCbCr422 RGB565/555 8-bit compressed data 8-/10-bit Raw RGB Data
Maximum Image Transfer Rate	UXGA	15 fps
	SVGA	30 fps
	CIF	60 fps
S/N Rate		40dB
Dynamic Range		50dB
substrate		FPC
IC Package		CSP-38PIN
Power requirement	Active	125mW(for 15fps, UXGA YUV mode) 140mW(for 15fps,UXGA compressed mode)
	Standby	900μA
Fixed Pattern noise		<1% of Vpeak-to-peak
Scan Mode		Progressive
Dark current		15mV/s at 60°C
Package		Antistatic Plastic

Pin Assignment

No.	Name	Pin type	Description
1	NC		
2	AGND	Ground	Analog Ground
3	SIO_D	I/O	SCCB serial interface data I/O
4	AVDD	Power	Analog power supply
5	SIO_C	Input	SCCB serial interface clock input
6	RESET	Input	Reset mode, active low Note: There is no internal pull-up/pull-down resistor.
7	VSYNC	I/O	Vertical sync output Default: Input
8	PWDN	Input	Power Down Mode Enable, active high Note: There is no internal pull-up/pull-down resistor.
9	HREF	I/O	HREF output Default: Input
10	DVDD	Power	Sensor digital power (Core)
11	DOVDD	Power	Power for digital video port
12	Y9	I/O	Video port output bit[9] Default: Input
13	XVCLK	Input	System clock input Note: There is no internal pull-up/pull-down resistor
14	Y8	I/O	Video port output bit[8] Default: Input
15	DGND	Ground	Digital Ground
16	Y7	I/O	Video port output bit[7] Default: Input
17	PCLK	I/O	Pixel clock output Default: Input
18	Y6	I/O	Video port output bit[6] Default: Input
19	Y2	I/O	Video port output bit[2] Default: Input
20	Y5	I/O	Video port output bit[5] Default: Input
21	Y3	I/O	Video port output bit[3] Default: Input
22	Y4	I/O	Video port output bit[4] Default: Input
23	Y1	I/O	Video port output bit[1] Default: Input
24	Y0	I/O	Video port output bit[0] Default: Input

Electrical Characteristics

1. Absolute Maximum Ratings

Ambient Storage Temperature		-40°C to +95°C
Supply Voltages (with respect to Ground)	V _{DD-A}	4.5V
	V _{DD-C}	3V
	V _{DD-IO}	4.5V
All Input/Output Voltages (with respect to Ground)		-0.3V to V _{DD-IO} +1V
Lead-free Temperature, Surface-mount process		245°C

NOTE: Exceeding the Absolute Maximum ratings shown above invalidates all AC and DC electrical specifications and may result in permanent device damage.

2. DC Characteristics (-30°C < Ta < 70°C)

Symbol	Parameter	Min	Typ	Max	Unit
Supply					
V _{DD-A}	Supply voltage	2.5 ^a	2.8	3.0	V
V _{DD-D}	Supply voltage	1.24	1.3	1.36	V
V _{DD-IO}	Supply voltage ^b	1.71	2.8	3.3	V
I _{DDA-A}	Active (operating) current ^c		30	40	mA
I _{DDA-D}	Active (operating) current ^c		30 (YUV) 45 (Compressed)	40 (YUV) 60 (Compressed)	mA
I _{DDA-IO}	Active (operating) current ^c		6	15	mA
I _{DDS-SCCB}	Standby current ^d		1	2	mA
I _{DDS-PWDN}			900	2000	μA
Digital Inputs					
V _{IL}	Input voltage LOW			0.54	V
V _{IH}	Input voltage HIGH	1.26			V
C _{IN}	Input capacitor			10	pF
Digital Outputs (standard loading 25 pF)					
V _{OH}	Output voltage HIGH	1.62			V
V _{OL}	Output voltage LOW			0.18	V
Serial Interface Inputs					
V _{IL}	SIO_C and SIO_D	-0.5	0	0.54	V
V _{IH}	SIO_C and SIO_D	1.26	1.8	2.3	V

a. If using internal regulator for DVDD, V_{DD-A} requires greater than or equal to 2.65V

b. 1.8V I/O is supported. Contact your local OmniVision FAE for further details.

c. At 25°C, V_{DD-A} = 2.8V, V_{DD-D} = 1.3V, and V_{DD-IO} = 1.8V for 15 fps in UXGA mode

d. I_{DDS-SCCB} refers to SCCB-initiated Standby, while I_{DDS-PWDN} refers to PWDN pad-initiated Standby

3. AC Characteristics ($T_A=25^{\circ}\text{C}$, $V_{DD-A}=2.8\text{V}$)

Symbol	Parameter	Min	Typ	Max	Unit
ADC Parameters					
B	Analog bandwidth		20		MHz
DLE	DC differential linearity error		0.5		LSB
ILE	DC integral linearity error		1		LSB
	Settling time for hardware reset			<1	ms
	Settling time for software reset			<1	ms
	Settling time for UXGA/SVGA mode change			<1	ms
	Settling time for register setting			<300	ms

4. Timing Characteristics

Symbol	Parameter	Min	Typ	Max	Unit
Oscillator and Clock Input					
f_{OSC}	Frequency (XVCLK)	6	24		MHz
t_r, t_f	Clock input rise/fall time			5	ns
	Clock input duty cycle	45	50	55	%

Note: For more information of sensor please refer to the OV2640 specification.

Appearance Specification

NO.	Item	Standard	Importance Class
1	Top side of Lens	No obvious impurity and oil impurity on the front of lens within the half area; The defect(unfeeling) limitation: width \leq 1mm, length \leq 2mm, the defect number \leq 2; No feeling defect; The width of defects and gaps on the outside of Lens \leq 0.3mm. Others are unlimited.	A
2	Screw glue	Normally screw glue shall be symmetrical distributed around lens circle side. Particular circs, glue distribution must not disturb customer's assembly operation.	A
3	L1 Glass	No defect and dust check from 45° angle under the reflexing light and from 0° under the highlight	A
4	Holder	No obvious impurity and distortion of outline. The width and length of defect is unlimited, the depth \leq 0.1mm and \leq 1/4 of the thickness of Holder.	B
5	Sealed glue	Sealed glue distributing between holder and FPC must be symmetrical and smooth. Not allow glue leakage and asymmetric thickness. After holder assembly, the thickness distance between one side and its opposite side shall be less than 0.2mm. Excess glue over the holder shall not make the outside dimension be out of control.	A
6	FPC/PCB	Edge defect limitation: width \leq 1/2H (H is minimum.), length \leq 1mm, defect numbers per edge \leq 2(No tearing gap inby edge for FPC); Edge outshoot limitation (width \leq 0.3mm, length \leq 1mm). No obvious impurity and crease on the surface. If there was shield film on the surface, the spot size of the film shall be less than 0.3mm \times 1mm and no line is exposed. If it was not be cleaned and did not influence the total thickness, it would be permitted. Label and mark shall be clear enough to be discerned.	A
7	Connector	No dust, fingerprint, and not allows to turning colors, distortion; Solder must be well; No open circuit or short circuit	A

8	Gold finger	No dust, fingerprint, and not allows to turning colors, burned, unsmoothed and peeled; No open circuit or short circuit; The defect width shall be smaller than 20% of gold finger's width. No copper/nickel exposed in defect. Numbers of defected pin shall be less than 3. The defect limitation:width \leq 0.08mm,length \leq 5mm.	A
9	Stiffener	Holder anchor pole length overtopping the steel plate shall be less than 0.2mm. No dust, rust and deep scratch on the steel surface without Double coated tapes.	B
10	Double coated tapes	Adhered direction shall be right. Not allows to excess steel plate edge. No alveoli and stick. Not allows to peel glue and rip protective paper when tear the protective paper.	B
11	Protective film	No dust in the glue side. Not allows to float or drop. Adhered direction shall be right.	B

Remark:

1. The definition of the appearance importance class

A: The defect can be found in the finished product, or have obvious visual differences from good products, such as crack, defect and dust, or influence image quality, or are appointed by the customer. We will emphasize these items and check all products.

B: The defect can be found in the finished product and has visual difference from the good one, but will not affect customer's aesthetic judgement. Or the defect can not be found in the finished product and will not generate functional problem, but will slightly influence sequential manufacture process or condition. We will supervise these items in the manufacturing process and check products selectively.

2. Sampling standard

Referenced standard: GB/T 2828.1-2003/ISO 2859-1:1999 and ANSI/ASQC.4-1993 II

Image Specification

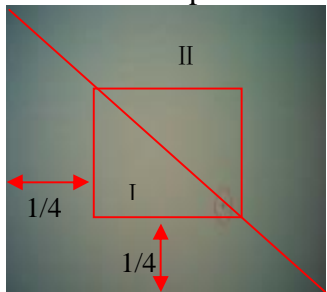
NO.	Item	Standard	Important Class
1	TV Line	Center \geq 700 8 point of 0.7 viewing field \geq 600	A
2	Shading	The lightness of 90% viewing area \geq 40% of center lightness(Lens correction Shading [Turn off]); The lightness of 90% viewing area \geq 60% of center lightness(Lens correction Shading [Turn on])	A
3	Dust	No dust in the center viewing area; Border area according to the limit samples	A
4	Dead pixel	No in the viewing area.	A
5	Wound pixel 	I area: Blemish number \leq 1 II area: Blemish number \leq 4	B
6	Color	Color distortion ratio of center \pm 15%	B
7	Gray Scale	Margin of two near scales' brightness \geq 6	B
8	Distortion	<1%	B
9	Flare	No flare in 45° viewing angle; No ghost in full viewing angle	B

QA Plan

NO.	Item	Sampling frequency	Measure	Remark
Image and reliability item				
1	TV Line	AQL 0.65 II Class	Same as production	100% Inspection
2	Shading	AQL 0.65 II Class	Same as production	100% Inspection
3	Dust	AQL 0.65 II Class	Same as production	100% Inspection
4	Dead pixel	AQL 0.65 II Class	Same as production	100% Inspection
5	Wound pixel	AQL 1.5 II Class	Same as production	100% Inspection
6	Color	AQL 1.5 II Class	Same as production	100% Inspection
7	Gray Scale	AQL 1.5 II Class	Same as production	100% Inspection
8	Distortion	N=5,c=0 per batch	Same as production	Sampling by QA
9	Flare	N=5,c=0 per batch	Same as production	Sampling by QA
Appearance Check Items				
1	Top side of Lens	AQL 1.0 II Class	Same as production	100% Inspection
2	Screw glue	AQL 1.0 II Class	Same as production	100% Inspection
3	L1 Glass	AQL 1.0 II Class	Same as production	100% Inspection
4	Holder	AQL 1.5 II Class	Same as production	100% Inspection
5	Sealed glue	AQL 1.0 II Class	Same as production	100% Inspection
6	FPC/PCB	AQL 1.0 II Class	Same as production	100% Inspection
7	Connector	AQL 1.0 II Class	Same as production	100% Inspection
8	Gold finger	AQL 1.0 II Class	Same as production	100% Inspection
9	Stiffener	AQL 1.5 II Class	Same as production	100% Inspection
10	Double coated tapes	AQL 1.5 II Class	Same as production	100% Inspection
11	Protective film	AQL 1.5 II Class	Same as production	100% Inspection

Sample:

Referenced standard: GB/T 2828.1-2003/ISO 2859-1:1999 and ANSI/ASQC.4-1993 II

Package Specification

Packaging Design One

Product No.	CM8021-A200SM-E	Release date									
Product name	Compact Camera Module	Releaser									
Supplier	TRULY SEMI CONDUCTORS LTD	Recycle	<input type="checkbox"/> YES <input checked="" type="checkbox"/> NO								
Quantity/ each box	TBD	Material for box	<input checked="" type="checkbox"/> paper <input type="checkbox"/> plastic								
Outer carton box size	405mm*290mm*290mm	Box type	<input checked="" type="checkbox"/> new <input type="checkbox"/> update								
Quantity / inner box * Quantity / outer box	TBD	Weight	<table border="1"> <tr> <td></td> <td>g / pcs</td> <td>BOX=TYPE Record of SRF Dept.</td> <td>TBD</td> </tr> <tr> <td></td> <td>Kg / outer box</td> <td></td> <td>Kg(Max)</td> </tr> </table>		g / pcs	BOX=TYPE Record of SRF Dept.	TBD		Kg / outer box		Kg(Max)
	g / pcs	BOX=TYPE Record of SRF Dept.	TBD								
	Kg / outer box		Kg(Max)								

Packing Standards:

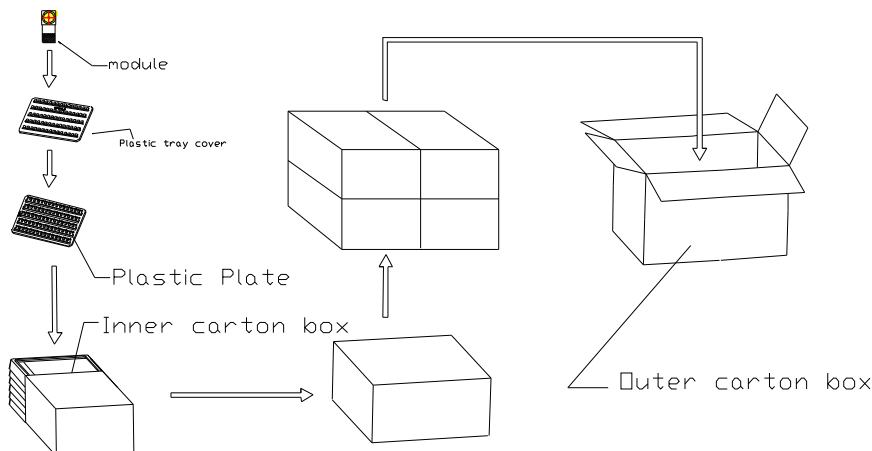

There are TBD modules each plastic plate.

There are TBD modules each inner carton box..

There are 4 each outer carton box.

Requirements of outer carton box :

1. Weight(Max): TBD Kg
2. Height (Max): 0.29 M
3. Prohibition: Box made by log

Material for Plastic tray

It is made of antistatic polystyrene which has no chemical pollution. Surface resistivity : 10^6 ohm/sq

Packaging Design Two

Product No.	CM8021-A200SM-E	Release date	
Product name	Compact Camera Module	Releaser	
Supplier	TRULY SEMI CONDUCTORS LTD	Recycle	<input type="checkbox"/> YES <input checked="" type="checkbox"/> NO
Quantity/ each box	TBD	Material for box	<input checked="" type="checkbox"/> paper <input type="checkbox"/> plastic
Outer carton box size	405 mm *280 mm *170 mm	Box type	<input checked="" type="checkbox"/> new <input type="checkbox"/> update
Quantity / inner box * Quantity / outer box	TBD	Weight	BOX=TYPE Record of SRF Dept.
		g / pcs Kg / outer box	TBD Kg(Max)

Packing Standards:

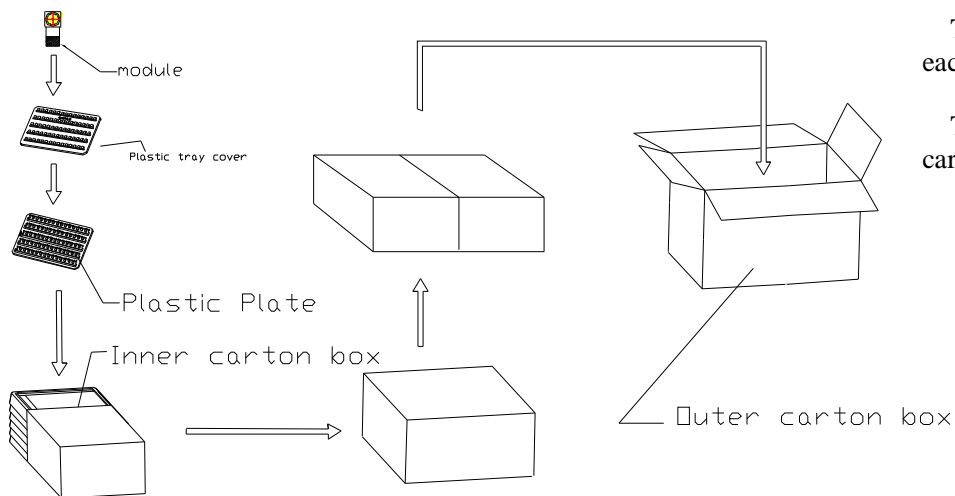

There are **TBD** modules each plastic plate.

There are **TBD** modules each inner carton box..

There are **2** each outer carton box.

Requirements of outer carton box :

4. Weight(Max): **TBD** Kg
5. Height (Max): 0.17 M
6. Prohibition: Box made by log

Material for Plastic tray

It is made of antistatic polystyrene which has no chemical pollution. Surface resistivity : 10^6 ohm/sq

PRIOR CONSULT MATTER

- 1.①For Truly standard products, we keep the right to change material, process for improving the product property without notice on our customer.
②For OEM products, if any change needed which may affect the product property, we will consult with our customer in advance.
2. If you have special requirement about reliability condition, please let us know before you start the test on our samples.

FACTORY CONTACT INFORMATION

FACTORY NAME: TRULY SEMICONDUCTORS LTD.

FACTORY ADDRESS: Truly Industrial Area, ShanWei City, GuangDong, China

FACTORY PHONE: 86-0660-3380061 **FAX:** 86-0660-3371772