

**PRODUCT** : CAMERA MODULE

**MODEL NO.** : CM2021-A200SM-E

**SUPPLIER** : TRULY SEMICONDUCTORS LTD.

**DATE** : June 7, 2007



CERT. No. 946535  
ISO9001  
TL9000

# SPECIFICATION

Revision: 0.2

**CM2021-A200SM-E**

preliminary

If there is no special request from customer, TRULY SEMICONDUCTORS Co., Ltd will not reserve the tooling of the product under the following conditions:

1. There is no response from customer in two years after TRULY SEMICONDUCTORS Co., Ltd submit the samples;
2. There is no order in two years after the latest mass production.

And correlated data (include quality record) will be reserved one year more after tooling was discarded.

**TRULY SEMICONDUCTORS LTD:**

**CUSTOMER:**

Quality Assurance Department: \_\_\_\_\_

Approved by:

Technical Department: \_\_\_\_\_

Approved by:



# CONTENTS

- n KEY INFORMATION
- n PIN ASSIGNMENT
- n ELECTRICAL CHARACTERISTICS
- n MECHANICAL DRAWING
- n APPEARANCE SPECIFICATION
- n IMAGE SPECIFICATION
- n QA PLAN
- n PACKAGE SPECIFICATION
- nPRIOR CONSULT MATTER
- nFACTORY CONTACT INFORMATION

WRITTEN BY	CHECKED BY	APPROVED BY
HUANG WEI NA	LIU TIE NAN	HUANG YU XIN

**Key Information**

<b>Module No.</b>		<b>CM2021-A200SM-E</b>
Module Size		9.0mm X9.0mm X 5.85~6.00mm
Image Quality		≥600 TV line
Sensor Type		OV2640
Array Size	UXGA	1600 X 1200
Power supply	core	1.3VDC +/-5%
	Analog	2.5~3.0 VDC
	I/O	1.7V to 3.3V
Lens		1/4 inch 4Plastic+ IR
Focus(F.NO)		2.8
View Angle		58.9°
Image Area		3590μm x 2684μm
Object distance		60cm-infinity (NORMAL) 8.8cm-10.2 cm(MACRO)
sensitivity		0.6V/Lux-sec
Pixel size		2.2μm x 2.2μm
IR Cutter		650+/-10nm
Temperature Range	Stable Image	0° C to 50° C
Output Formats(8-bit)		YUV(422/420)/YCbCr422 RGB565/555 8-bit compressed data 8-/10-bit Raw RGB Data
Maximum Image Transfer Rate	UXGA	15 fps
	SVGA	30 fps
	CIF	60 fps
S/N Rate		40dB
Dynamic Range		50dB
substrate		FPC
IC Package		CSP-38PIN
Power requirement	Active	125mW(for 15fps, UXGA YUV mode) 140mW(for 15fps,UXGA compressed mode)
	Standby	TBD
Fixed Pattern noise		<1% of Vpeak-to-peak
Scan Mode		Progressive
Dark current		15mV/s at 60°C
Package		Antistatic Plastic

## Pin Assignment

No.	Name	Pin type	Description
1	MF-VDD	Power	Macro driver voltage
2	AGND	Ground	Analog Ground
3	SIO_D	I/O	SCCB serial interface data I/O
4	AVDD	Power	Analog power supply
5	SIO_C	Input	SCCB serial interface clock input
6	RESET	Input	Reset mode, active low Note: There is no internal pull-up/pull-down resistor.
7	VSYNC	I/O	Vertical sync output Default: Input
8	PWDN	Input	Power Down Mode Enable, active high Note: There is an internal pull-down resistor.
9	HREF	I/O	HREF output Default: Input
10	DVDD	Power	Sensor digital power (Core)
11	DOVDD	Power	Power for digital video port
12	Y9	I/O	Video port output bit[9]      Default: Input
13	XVCLK1	Input	System clock input Note: There is no internal pull-up/pull-down resistor
14	Y8	I/O	Video port output bit[8]      Default: Input
15	GND	Ground	Ground
16	Y7	I/O	Video port output bit[7]      Default: Input
17	PCLK	I/O	Pixel clock output              Default: Input
18	Y6	I/O	Video port output bit[6]      Default: Input
19	Y2	I/O	Video port output bit[2]      Default: Input
20	Y5	I/O	Video port output bit[5]      Default: Input
21	Y3	I/O	Video port output bit[3]      Default: Input
22	Y4	I/O	Video port output bit[4]      Default: Input
23	MF-CTR2	Input	Macro control pin2
24	MF-CTR1	Input	Macro control pin1

## Electrical Characteristics

### 1. Absolute Maximum Ratings

<b>Ambient Storage Temperature</b>		-40°C to +95°C
<b>Supply Voltages (with respect to Ground)</b>	<b>V<sub>DD-A</sub></b>	4.5V
	<b>V<sub>DD-C</sub></b>	3V
	<b>V<sub>DD-IO</sub></b>	4.5V
<b>All Input/Output Voltages (with respect to Ground)</b>		-0.3V to V <sub>DD-IO</sub> +1V
<b>Lead-free Temperature, Surface-mount process</b>		245°C

**NOTE:** Exceeding the Absolute Maximum ratings shown above invalidates all AC and DC electrical specifications and may result in permanent device damage.

### 2. DC Characteristics (-30°C < T<sub>a</sub> < 70°C)

Symbol	Parameter	Min	Typ	Max	Unit
<b>Supply</b>					
V <sub>DD-A</sub>	Supply voltage	2.5 <sup>a</sup>	2.8	3.0	V
V <sub>DD-D</sub>	Supply voltage	1.24	1.3	1.36	V
V <sub>DD-IO</sub>	Supply voltage <sup>b</sup>	1.71	2.8	3.3	V
I <sub>DDA-A</sub>	Active (Operating) Current <sup>c</sup>		30	40	mA
I <sub>DDA-D</sub>	Active (Operating) Current <sup>c</sup>		30 (YUV) 45 (Compressed)	40 (YUV) 60 (Compressed)	mA
I <sub>DDA-IO</sub>	Active (Operating) Current <sup>c</sup>		6	15	mA
I <sub>DDS-SCCB</sub>	Standby Current <sup>d</sup>		1	2	mA
I <sub>DDS-PWDN</sub>			600	1200	μA
<b>Digital Inputs</b>					
V <sub>IL</sub>	Input voltage LOW			0.54	V
V <sub>IH</sub>	Input voltage HIGH	1.26			V
C <sub>IN</sub>	Input capacitor			10	pF
<b>Digital Outputs (standard loading 25 pF)</b>					
V <sub>OH</sub>	Output voltage HIGH	1.62			V
V <sub>OL</sub>	Output voltage LOW			0.18	V
<b>Serial Interface Inputs</b>					
V <sub>IL</sub>	SIO_C and SIO_D	-0.5	0	0.54	V
V <sub>IH</sub>	SIO_C and SIO_D	1.26	1.8	2.3	V

a. If using internal regulator for DVDD, V<sub>DD-A</sub> requires greater than or equal to 2.65V

b. 1.8V I/O is supported. Contact your local OmniVision FAE for further details.

c. V<sub>DD-A</sub> = 2.8V, V<sub>DD-D</sub> = 1.3V, and V<sub>DD-IO</sub> = 1.8V for 15 fps in UXGA mode

d. I<sub>DDS-SCCB</sub> refers to SCCB-initiated Standby, while I<sub>DDS-PWDN</sub> refers to PWDN pad-initiated Standby

### 3. AC Characteristics (T<sub>A</sub>=25°C, V<sub>DD-A</sub>=2.8V)

Symbol	Parameter	Min	Typ	Max	Unit
<b>ADC Parameters</b>					
B	Analog bandwidth		20		MHz
DLE	DC differential linearity error		0.5		LSB
ILE	DC integral linearity error		1		LSB
	Settling time for hardware reset			<1	ms
	Settling time for software reset			<1	ms
	Settling time for UXGA/SVGA mode change			<1	ms
	Settling time for register setting			<300	ms

#### 4. Timing Characteristics

Symbol	Parameter	Min	Typ	Max	Unit
<b>Oscillator and Clock Input</b>					
f <sub>osc</sub>	Frequency (XVCLK)	6	24		MHz
t <sub>r</sub> , t <sub>f</sub>	Clock input rise/fall time			5	ns
	Clock input duty cycle	45	50	55	%

**Note:** For more information of sensor please refer to the OV2640 specification.

## CM2021-A200SM-E Camera Module

Customer No.:

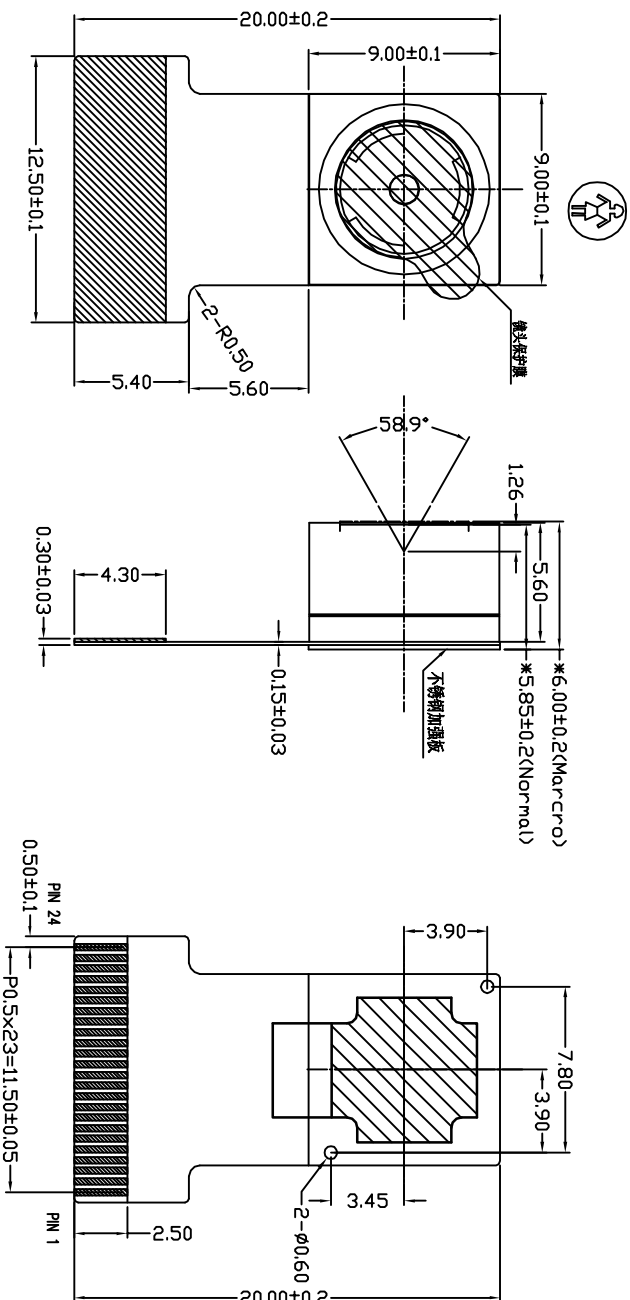

### 24PIN DESCRIPTION

NO.	SIGNAL	NO.	SIGNAL
1	MF_VDD	24	MF_CTR1
2	AGND	23	MF_CTR2
3	SIO_D	22	Y4
4	AVDD(2.8V)	21	Y3
5	SIO_C	20	Y5
6	RESET	19	Y2
7	VSYNC	18	Y6
8	PWDN	17	PCLK
9	HREF	16	Y7
10	DVDD(1.3V)	15	GND
11	DOVDD	14	Y8
12	Y9	13	XVCLK1

\* 为关键尺寸  
未注圆角R0.2MM

AVDD: 2.5~3.0V  
DOVDD: 1.7~3.3V  
DVDD: 1.3V±5%  
MF\_VDD: 2.8V

### CUSTOMER APPROVE

Mechanical Electrical

### AMEND

光电感应模组

TRULY SEMICONDUCTORS LTD.

PRODUCT NO. CM2021-A200SM-E DRAW NO. REV C

D/WN 严思志 20070406 DSN 严思志 20070406

CHKD 马亮 20070406 APPD 黄育新 20070406

UNIT mm SHEET:

NOT IN SCALE

### 主要参数 (Module Specification)

焦距 (FFL)	3.85mm
光圈 (F. NO)	2.8
视场角 (View Angle)	58.9°
畸变 (Distortion)	< 1 %
解析力 (Image Quality)	≥600 TV line
景深 (Focusing Range)	60 cm~Infinity (NORMAL) 8.8cm~10.2cm (MACRO)
感光芯片 (Chip Type)	OV2640
像素 (Array Size)	2.0M
镜头类型 (Lens Size)	1/4 INCH 4P+1R

NAME QTY Part No.

TOLERANCE :

DECIMAL

x ± .30

xx ± .20

≤ ± 1/4

### Appearance Specification

NO.	Item	Standard	Importance Class
1	Top side of Lens	No obvious impurity and oil impurity on the front of lens within the half area; The defect(unfeeling) limitation: width $\leq$ 1mm, length $\leq$ 2mm, the defect number $\leq$ 2; No feeling defect; The width of defects and gaps on the outside of Lens $\leq$ 0.3mm. Others are unlimited.	A
2	Screw glue	Glue homogeneous distributing around lens circle side .Not allows to excess glue over the height of Lens and Holder outside.	A
3	L1 Glass	No defect and dust check from 45° angle under the reflexing light and from 0° under the highlight	A
4	Holder	No obvious impurity and distortion of outline. The width and length of defect is unlimited, the depth $\leq$ 0.1mm and $\leq$ 1/4 of the thickness of Holder.	B
5	Sealed glue	Glue distributing between holder and FPC must be homogeneous and smooth. Not allows to excess glue over the width of holder.	A
6	FPC/PCB	Edge defect limitation: width $\leq$ 1/2H(H is minimum.)、 length $\leq$ 1mm、 defect numbers per edge $\leq$ 2(No tearing gap inby edge for FPC); Edge outshoot limitation (width $\leq$ 0.3mm,length $\leq$ 1mm); No obvious impurity on the surface, label and mark shall be recognizable and Clear	A
7	Connector	No dust, fingerprint, and not allows to turning colors, distortion; Solder must be well; No open circuit or short circuit	A
8	Gold finger	No dust, fingerprint, and not allows to turning colors, burned, unsmoothed and peeled; No open circuit or short circuit; The defect width shall be smaller than 20% of gold finger's width. No copper/nickel exposed in defect. Numbers of defected pin shall be less than 3. The defect limitation:width $\leq$ 0.08mm,length $\leq$ 5mm.	A
9	Stiffener	Holder anchor pole length overtopping the steel plate shall be less than 0.2mm. No dust, rust and deep scratch on the steel surface without Double coated tapes.	B

10	Double coated tapes	Adhered direction shall be right. Not allows to excess steel plate edge. No alveoli and stick. Not allows to peel glue and rip protective paper when tear the protective paper.	B
11	Protective film	No dust in the glue side. Not allows to float or drop. Adhered direction shall be right.	B

## Remark:

## 1. The definition of the appearance importance class

A: The defect can be found in the finished product, or have obvious visual differences from good products, such as crack, defect and dust, or influence image quality, or are appointed by the customer. We will emphasize these items and check all products.

B: The defect can be found in the finished product and has visual difference from the good one, but will not affect customer's aesthetic judgement. Or the defect can not be found in the finished product and will not generate functional problem, but will slightly influence sequential manufacture process or condition. We will supervise these items in the manufacturing process and check products selectively.

## 2. Sampling standard

Referenced standard: GB/T 2828.1-2003/ISO 2859-1:1999 and ANSI/ASQC.4-1993 II

### Image Specification

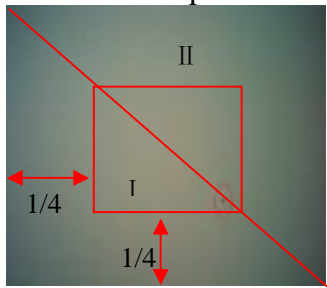
NO.	Item	Standard	Important Class
1	TV Line	Center $\geq$ 700 8 point of 0.7 viewing field $\geq$ 600	A
2	Shading	The lightness of 90% viewing area $\geq$ 40% of center lightness(Lens correction Shading [Turn off]); The lightness of 90% viewing area $\geq$ 60% of center lightness(Lens correction Shading [Turn on])	A
3	Dust	No dust in the center viewing area; Border area according to the limit samples	A
4	Dead pixel	No in the viewing area.	A
5	Wound pixel	 <p>I area: Blemish number <math>\leq</math> 1 II area: Blemish number <math>\leq</math> 4</p>	B
6	Color	Color distortion ratio of center $\pm$ 15%	B
7	Gray Scale	Margin of two near scales' brightness $\geq$ 6	B
8	Distortion	$<$ 1%	B
9	Flare	No flare in 45° viewing angle; No ghost in full viewing angle	B

## QA Plan

NO.	Item	Sampling frequency	Measure	Remark
Image and reliability item				
1	TV Line	AQL 0.65 II Class	Same as production	100% Inspection
2	Shading	AQL 0.65 II Class	Same as production	100% Inspection
3	Dust	AQL 0.65 II Class	Same as production	100% Inspection
4	Dead pixel	AQL 0.65 II Class	Same as production	100% Inspection
5	Wound pixel	AQL 1.5 II Class	Same as production	100% Inspection
6	Color	AQL 1.5 II Class	Same as production	100% Inspection
7	Gray Scale	AQL 1.5 II Class	Same as production	100% Inspection
8	Distortion	N=5,c=0 per batch	Same as production	Sampling by QA
9	Flare	N=5,c=0 per batch	Same as production	Sampling by QA
Appearance Check Items				
1	Top side of Lens	AQL 1.0 II Class	Same as production	100% Inspection
2	Screw glue	AQL 1.0 II Class	Same as production	100% Inspection
3	L1 Glass	AQL 1.0 II Class	Same as production	100% Inspection
4	Holder	AQL 1.5 II Class	Same as production	100% Inspection
5	Sealed glue	AQL 1.0 II Class	Same as production	100% Inspection
6	FPC/PCB	AQL 1.0 II Class	Same as production	100% Inspection
7	Connector	AQL 1.0 II Class	Same as production	100% Inspection
8	Gold finger	AQL 1.0 II Class	Same as production	100% Inspection
9	Stiffener	AQL 1.5 II Class	Same as production	100% Inspection
10	Double coated tapes	AQL 1.5 II Class	Same as production	100% Inspection
11	Protective film	AQL 1.5 II Class	Same as production	100% Inspection

Sample:

Referenced standard: GB/T 2828.1-2003/ISO 2859-1:1999 and ANSI/ASQC.4-1993 II

## Package Specification

### Packaging Design One

Product No.	CM2021-A200SM-E	Release date									
Product name	Compact Camera Module	Releaser									
Supplier	TRULY SEMI CONDUCTORS LTD	Recycle	<input type="checkbox"/> YES <input checked="" type="checkbox"/> NO								
Quantity/ each box	TBD	Material for box	<input checked="" type="checkbox"/> paper <input type="checkbox"/> plastic								
Outer carton box size	405mm*290mm*290mm	Box type	<input checked="" type="checkbox"/> new <input type="checkbox"/> update								
Quantity / inner box * Quantity / outer box	TBD	Weight	<table border="1"> <tr> <td></td> <td>g / pcs</td> <td>BOX=TYPE Record of SRF Dept.</td> <td>TBD</td> </tr> <tr> <td></td> <td>Kg / outer box</td> <td></td> <td>Kg(Max)</td> </tr> </table>		g / pcs	BOX=TYPE Record of SRF Dept.	TBD		Kg / outer box		Kg(Max)
	g / pcs	BOX=TYPE Record of SRF Dept.	TBD								
	Kg / outer box		Kg(Max)								

#### Packing Standards:

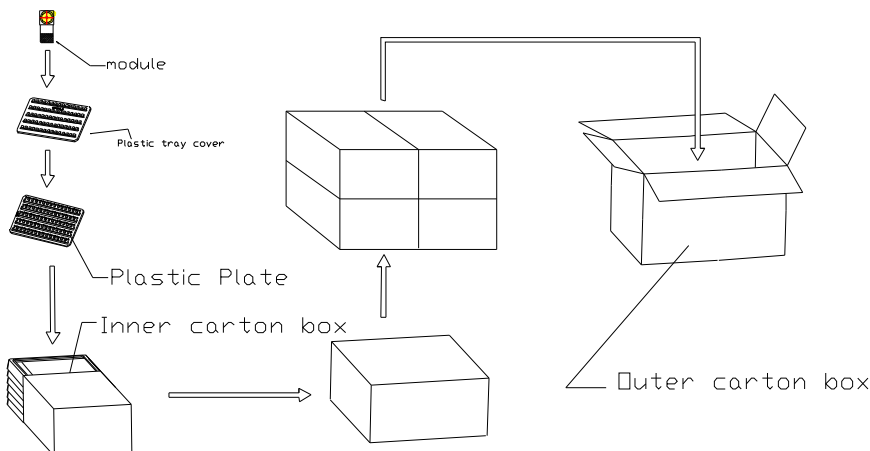

There are TBD modules each plastic plate.

There are TBD modules each inner carton box..

There are 4 each outer carton box.

#### Requirements of outer carton box :

1. Weight(Max): TBD Kg
2. Height (Max): 0.29 M
3. Prohibition: Box made by log

#### Material for Plastic tray

It is made of antistatic polystyrene which has no chemical pollution. Surface resistivity :  $10^6$  ohm/sq

## Packaging Design Two

Product No.	CM2021-A200SM-E	Release date							
Product name	Compact Camera Module	Releaser							
Supplier	TRULY SEMI CONDUCTORS LTD	Recycle	<input type="checkbox"/> YES <input checked="" type="checkbox"/> NO						
Quantity/ each box	TBD	Material for box	<input checked="" type="checkbox"/> paper <input type="checkbox"/> plastic						
Outer carton box size	405 mm *280 mm *170 mm	Box type	<input checked="" type="checkbox"/> new <input type="checkbox"/> update						
Quantity / inner box * Quantity / outer box	TBD	Weig ht	<table border="1"> <tr> <td>g / pcs</td> <td>BOX=TYPE Record of SRF Dept.</td> <td>TBD</td> </tr> <tr> <td>Kg / outer box</td> <td></td> <td>Kg(Max)</td> </tr> </table>	g / pcs	BOX=TYPE Record of SRF Dept.	TBD	Kg / outer box		Kg(Max)
g / pcs	BOX=TYPE Record of SRF Dept.	TBD							
Kg / outer box		Kg(Max)							

### Packing Standards:

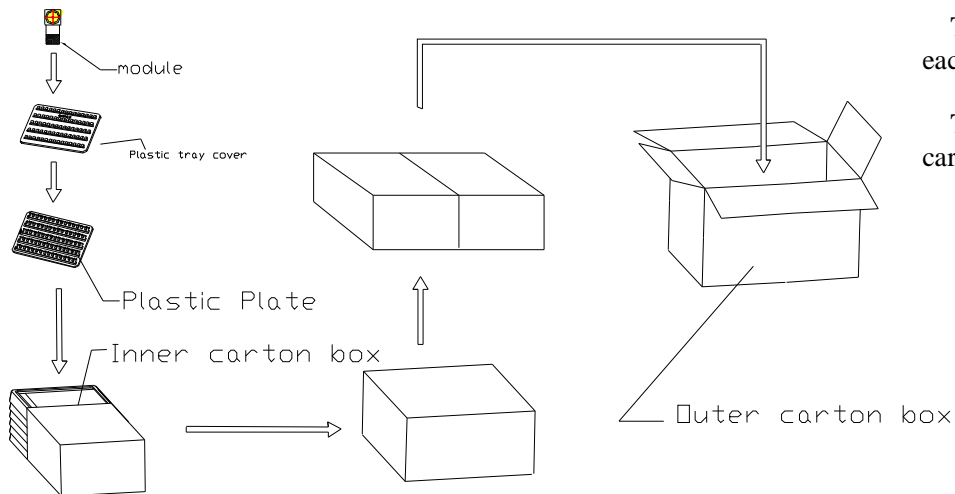

There are TBD modules each plastic plate.

There are TBD modules each inner carton box..

There are 2 each outer carton box.

### Requirements of outer carton box :

4. Weight(Max): TBD Kg
5. Height (Max): 0.17 M
6. Prohibition: Box made by log

### Material for Plastic tray

It is made of antistatic polystyrene which has no chemical pollution. Surface resistivity :  $10^6$  ohm/sq

## **PRIOR CONSULT MATTER**

- 1.①For Truly standard products, we keep the right to change material, process for improving the product property without notice on our customer.  
②For OEM products, if any change needed which may affect the product property, we will consult with our customer in advance.
2. If you have special requirement about reliability condition, please let us know before you start the test on our samples.

## **FACTORY CONTACT INFORMATION**

**FACTORY NAME:** TRULY SEMICONDUCTORS LTD.

**FACTORY ADDRESS:** Truly Industrial Area, ShanWei City, GuangDong, China

**FACTORY PHONE:** 86-0660-3380061    **FAX:** 86-0660-3371772