

**PRODUCT** : CAMERA MODULE  
**MODEL NO.** : CM8078-A300BA-E  
**SUPPLIER** : TRULY SEMICONDUCTORS LTD.  
**DATE** : November 28, 2007



CERT. No. 946535  
ISO9001  
TL9000

# SPECIFICATION

Revision: 1.1

**CM8078-A300BA-E**

If there is no special request from customer, TRULY SEMICONDUCTORS Co., Ltd will not reserve the tooling of the product under the following conditions:  
1. There is no response from customer in two years after TRULY SEMICONDUCTORS Co., Ltd submit the samples;  
2. There is no order in two years after the latest mass production.  
And correlated data (include quality record) will be reserved one year more after tooling was discarded.

**TRULY SEMICONDUCTORS LTD:      CUSTOMER:**

Quality Assurance Department: \_\_\_\_\_  
Approved by:  
  
Technical Department: \_\_\_\_\_

Approved by:



# CONTENTS

- n KEY INFORMATION
- n PIN ASSIGNMENT
- n ELECTRICAL CHARACTERISTICS
- n MECHANICAL DRAWING
- n APPEARANCE SPECIFICATION
- n IMAGE SPECIFICATION
- n QA PLAN
- n PACKAGE SPECIFICATION
- n PRIOR CONSULT MATTER
- n FACTORY CONTACT INFORMATION

WRITTEN BY	CHECKED BY	APPROVED BY
LI JING	YAN SI ZHI	LIU TIE NAN

**Key Information**

<b>Module No.</b>		<b>CM8078-A300BA-E</b>
Module Size		10.0mm x 10.0mm x 7.30mm
Image Quality		≥800 TV line
Sensor Type		NOON300PC51
Array Size		2048 X 1536(QXGA)
Power Supply		2.8V/1.5V
Power Consumption		TBD@15fps,QXGA
Lens		1/3 inch 4Plastic+ IR
Focus(F.NO)		2.8
View Angle		64°
Object distance		10cm-infinity
Frame Rate		15fps@QXGA,30fps@XGA
Color Filter		RGB Bayer
Master Clock		48MHz (Max)
Sensor Temperature Range	Operation	-20° C to 60° C
	Storage	-30° C to 80° C
Output Formats(10-bit)		.YUV 4:2:2 .RGB 5:6:5 .RGB 4:4:4,ITU656-like
Sub-sample	QVGA,	1/4
	QQVGA,	1/16
IC Package		COB
substrate		FPC
Assembly technique		Plastic Rivet+Glue
ADC		10bit
Package		Antistatic Plastic

## Pin Assignment

No.	Name	Pin type	Description
1	AF_VDD	Power	VCM Power Supply
2	AGND	Power	Analog Circuit Ground
3	SIOD	Bi-direction	Data for two-wire serial interface
4	AVDD	Power	Analog Circuit Power Supply Voltage
5	SIOC	Input	Clock for two-wire serial interface
6	RESET	Input	RESEB initializes sensor. Active Low
7	VSYNC	Output	Vertical synchronization
8	POWN	Input	CHIP_ENABLE enables sensor. 1: chip_enable, 0:power down
9	HREF	Output	Horizontal synchronization
10	DVDD	Power	Digital Core Circuit Power Supply Voltage
11	DOVDD	Power	Digital I/O Circuit Power Supply Voltage
12	Y9	Output	Image Data<9>
13	XCLK	Input	Master Clock
14	Y8	Output	Image Data<8>
15	DGND	Power	Digital Core Circuit ground
16	Y7	Output	Image Data<7>
17	PCLK	Output	PCLK synchronizes D<9:0>.
18	Y6	Output	Image Data<6>
19	Y2	Output	Image Data<2>
20	Y5	Output	Image Data<5>
21	Y3	Output	Image Data<3>
22	Y4	Output	Image Data<4>
23	Y1	Output	Image Data<1>
24	Y0	Output	Image Data<0>

## Electrical Characteristics

### 1. DC Characteristics

Item	Symbol	Min	Typ	Max	Unit	Note
Digital Core Circuit Power Supply Voltage	$V_{DD:D}$	1.4	1.5	1.6	V	
Analog Circuit Power Supply Voltage	$V_{DD:A}$	2.6	2.8	3.0	V	
Analog Pixel Circuit Power Supply Voltage	$V_{DD:P}$	2.6	2.8	3.0	V	
Digital I/O Circuit Power Supply Voltage	$V_{DD:I}$	1.4		3.0	V	
H level Input Voltage	$V_{IH}$	$0.7 \cdot V_{DD:I}$			V	
L level Input Voltage	$V_{IL}$			$0.3 \cdot V_{DD:I}$	V	
Output High Current ( $V_{DD:I} = 2.8V$ , $V_{OH} = 2.4V$ )	$I_{OH}$		4.3		mA	1
Output High Current ( $V_{DD:I} = 1.5V$ , $V_{OH} = 1.1V$ )	$I_{OH}$		2.4		mA	1
Output Low Current ( $V_{DD:I} = 2.8V$ , $V_{OL} = 0.4V$ )	$I_{OL}$		5.5		mA	1
Output Low Current ( $V_{DD:I} = 1.5V$ , $V_{OL} = 0.4V$ )	$I_{OL}$		3.8		mA	1

Note1) User can control the amount of current by controlling bit[7:4] of PWRCTL[0x01:P0].

Above values are output current when bit[7:4] of PWRCTL[0x01:P0] is 4'b0101.

### 2. AC Characteristics

Item	Symbol	Min	Typ	Max	Unit	Note
MCLK	Frequency	12		48	MHz	
MCLK	Duty Cycle	45	50	55	%	
PCLK	Frequency			110	MHz	
PCLK	Duty Cycle	40	50	60	%	
SC	Frequency			400	KHz	
HSYNC(VSYNC) rising time	$T_1$			4.6	ns	2
HSYNC(VSYNC) falling time	$T_2$			3.6	ns	2
PCLK rising time	$T_5$			4.6	ns	2
PCLK falling time	$T_6$			3.6	ns	2
HSYNC(VSYNC) rising time	$T_1$			6.2	ns	3
HSYNC(VSYNC) falling time	$T_2$			3.8	ns	3
PCLK rising time	$T_5$			6.2	ns	3
PCLK falling time	$T_6$			3.8	ns	3
Setup time of PCLK - HSYNC	$T_7$	2			ns	
Hold time of PCLK - HSYNC	$T_8$	2			ns	
Setup time of PCLK - D[7:0]	$T_3$	2			ns	
Hold time of PCLK - D[7:0]	$T_4$	2			ns	

Note2) Output load capacitance = 20pF,  $V_{DD:A}$  &  $V_{DD:P} = 2.8V$ ,  $V_{DD:C} = 1.5V$ ,  $V_{DD:I} = 2.8V$ ,  $V_{OH} = 2.4V$ ,  $V_{OL} = 0.4V$

Note3) Output load capacitance = 20pF,  $V_{DD:A}$  &  $V_{DD:P} = 2.8V$ ,  $V_{DD:C} = 1.5V$ ,  $V_{DD:I} = 1.5V$ ,  $V_{OH} = 1.1V$ ,  $V_{OL} = 0.4V$

User can control the rising(falling) time by controlling bit[7:4] of PWRCTL[0x01:P0].

Above values are rising(falling) time when bit[7:4] of PWRCTL[0x01:P0] is 4'b0101.

### 3. Temperature Characteristics

Item	Symbol	Rating	Unit	Note
Storage Temperature	T <sub>STR</sub>	-30 ~ 80	°C	
Functional Operating Temperature	T <sub>FUN</sub>	-20 ~ 60	°C	Camera fully functional
Optimum Operation Temperature	T <sub>OPT</sub>	5 ~30	°C	No visible degradation in image quality

### 4. Power Consumption

Item	Condition	Min	Typ	Max	Unit	Note
QXGA @15fps	V <sub>DD:A</sub> & V <sub>DD:P</sub> =2.8V		TBD		mA	4
	V <sub>DD:I</sub> =2.8V		TBD		mA	5
	V <sub>DD:C</sub> =1.5V		TBD		mA	
XGA @ 30fps	V <sub>DD:A</sub> & V <sub>DD:P</sub> =2.8V		TBD		mA	4
	V <sub>DD:I</sub> =2.8V		TBD		mA	5
	V <sub>DD:C</sub> =1.5V		TBD		mA	
Stand by Current			TBD		uA	6

Note4) Because current of analog circuit depends on the registers' values, refer to the recommended registers' values.

Note5) Because power consumption of VDD:I depends on the output load and system environment, user should supply enough current to sensor for stable operation. It is measured when output load is floated.

Note6) Stand by current is measured at Chip Enable = LO and MCLK = LO.

We recommend that power should be turned off, when low standby power consumption is required.

### Timing Specifications

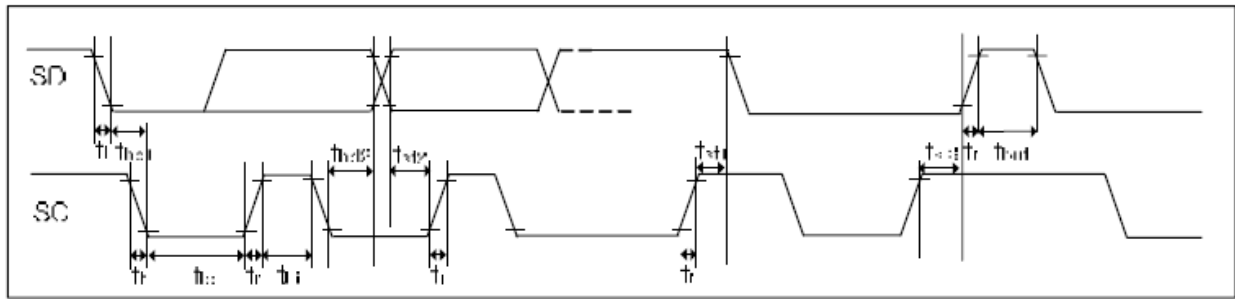

Parameter	Symbol	Min.	Typ.	Max.	Unit
SC frequency	$f_{sok}$			400	KHz
SC low period	$t_{lo}$	1.2		-	us
SC high period	$t_{hi}$	0.6		-	us
SC setup time for START condition	$t_{st1}$	0.6		-	us
SC setup time for STOP condition	$t_{st3}$	0.6		-	us
SC hold time for START condition	$t_{hd1}$	0.6		-	us
SD setup time	$t_{st2}$	0.6		-	us
SD hold time	$t_{hd2}$	0.6		-	us
Bus free time Between a STOP and START condition	$t_{buf}$	0.6		-	us
Rising time of both SD and SC	$t_r$	-		0.3	us
Falling time of both SD and SC	$t_f$	-		0.3	us
Capacitive load of SC/SD	$C_b$	-		200	pF
Pull-up resistor on SC and SD			4.7		k $\Omega$

**Note:** For more information of sensor please refer to the NOON300PC51 specification.

# ROHS

## CM8078-A300BA-E Camera Module

Customer No.:

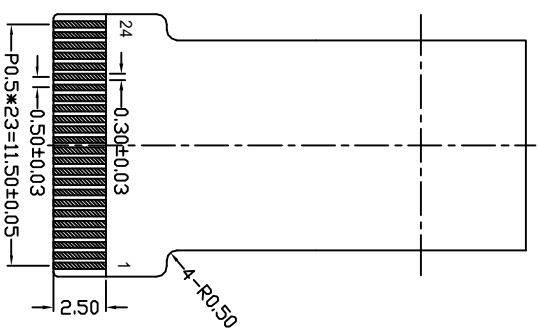
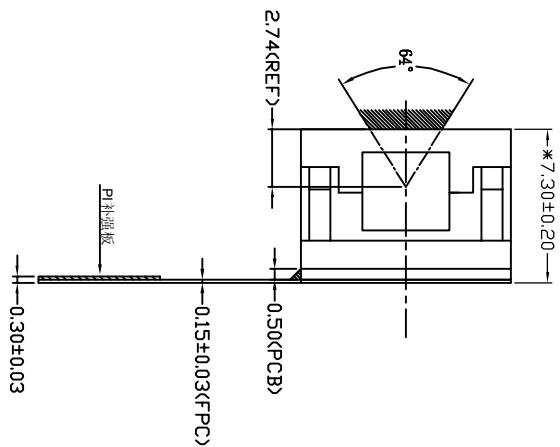
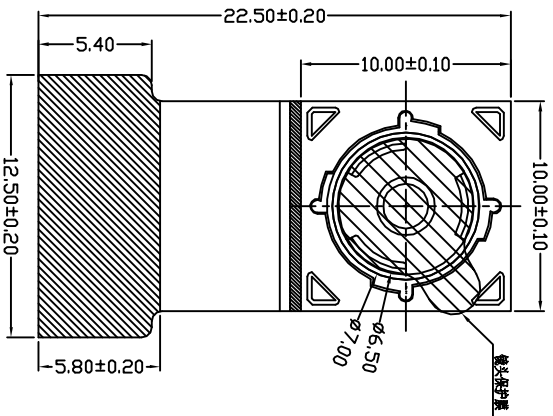

备注:  
1. 带\*尺寸为关键尺寸;  
2. 未标注圆角为R0.2.

Lens Specification	
EFL	4.79mm
F.NO	2.8
Field Of View	64°
Distortion	<1%
Image Quality	≥800TV Line
Chip Type	NOON300PC51
Array Size	3.0M
Lens Size	1/3 INCH
Lens Construction	4P+IR
Focus Area	10cm-infinity

CUSTOMER APPROVE		AMEND		光电感应模组		TRULY SEMICONDUCTORS LTD.	
Mechanical	Electrical			TOLERANCE !	PRODUCT NO.	DRAW NO.	REV
△	△			× ± .30	CM8078-A300BA-E		B
△	△			xxx ± .20	DVN 黄丽玲 20071114	DSN 黄丽玲 20071114	
△	△			< ± 1/4	修改PIN定义、影像方向	APPD 刘铁楠 20071114	
		NO.	CONTENT	DATE			

24PIN DESCRIPTION	
PIN NO	NAME
1	AF_VDD
2	AGND
3	STDD
4	AVDD
5	SDIC
6	RESET
7	VSYNC
8	PVDN
9	HREF
10	DVDD
11	DDVDD
12	Y9
13	XCLK
14	Y8
15	DGND
16	Y7
17	PCLK
18	Y6
19	Y2
20	Y5
21	Y3
22	Y4
23	Y1
24	Y0

**Appearance Specification**

NO.	Item	Standard	Importance Class
1	Top side of Lens	No obvious impurity and oil impurity on the front of lens within the half area; The defect(unfeeling) limitation: width $\leq$ 1mm, length $\leq$ 2mm, the defect number $\leq$ 2; No feeling defect; The width of defects and gaps on the outside of Lens $\leq$ 0.3mm. Others are unlimited.	A
2	Screw glue	Normally screw glue shall be symmetrical distributed around lens circle side. Particular circs, glue distribution must not disturb customer's assembly operation.	A
3	L1 Glass	No defect and dust check from 45° angle under the reflexing light and from 0° under the highlight	A
4	Holder	No obvious impurity and distortion of outline. The width and length of defect is unlimited, the depth $\leq$ 0.1mm and $\leq$ 1/4 of the thickness of Holder.	B
5	Sealed glue	Sealed glue distributing between holder and FPC must be symmetrical and smooth. Not allow glue leakage and asymmetric thickness. After holder assembly, the thickness distance between one side and its opposite side shall be less than 0.2mm. Excess glue over the holder shall not make the outside dimension be out of control.	A
6	FPC/PCB	Edge defect limitation: width $\leq$ 1/2H (H is minimum.)、 length $\leq$ 1mm、 defect numbers per edge $\leq$ 2(No tearing gap inby edge for FPC); Edge outshoot limitation (width $\leq$ 0.3mm, length $\leq$ 1mm). No obvious impurity and crease on the surface. If there was shield film on the surface, the spot size of the film shall be less than 0.3mm $\times$ 1mm and no line is exposed. If it was not be cleaned and did not influence the total thickness, it would be permitted. Label and mark shall be clear enough to be discerned.	A
7	Connector	No dust, fingerprint, and not allows to turning colors, distortion; Solder must be well; No open circuit or short circuit	A

8	Gold finger	No dust, fingerprint, and not allows to turning colors, burned, unsmoothed and peeled; No open circuit or short circuit; The defect width shall be smaller than 20% of gold finger's width. No copper/nickel exposed in defect. Numbers of defected pin shall be less than 3. The defect limitation:width $\leq$ 0.08mm,length $\leq$ 5mm.	A
9	Stiffener	Holder anchor pole length overtopping the steel plate shall be less than 0.2mm. No dust, rust and deep scratch on the steel surface without Double coated tapes.	B
10	Double coated tapes	Adhered direction shall be right. Not allows to excess steel plate edge. No alveoli and stick. Not allows to peel glue and rip protective paper when tear the protective paper.	B
11	Protective film	No dust in the glue side. Not allows to float or drop. Adhered direction shall be right.	B

Remark:

1. The definition of the appearance importance class

- A: The defect can be found in the finished product, or have obvious visual differences from good products, such as crack, defect and dust, or influence image quality, or are appointed by the customer. We will emphasize these items and check all products.
- B: The defect can be found in the finished product and has visual difference from the good one, but will not affect customer's aesthetic judgement. Or the defect can not be found in the finished product and will not generate functional problem, but will slightly influence sequential manufacture process or condition. We will supervise these items in the manufacturing process and check products selectively.

2. Sampling standard

Referenced standard: GB/T 2828.1-2003/ISO 2859-1:1999 and ANSI/ASQC.4-1993 II

### Image Specification

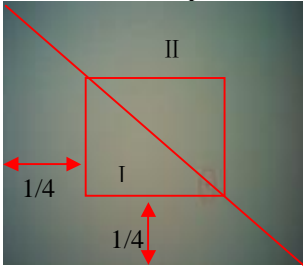
NO.	Item	Standard	Important Class
1	TV Line	Center $\geq 1000$ 8 point of 0.7 viewing field $\geq 800$	A
2	Shading	The lightness of 90% viewing area $\geq 40\%$ of center lightness(Lens correction Shading [Turn off]); The lightness of 90% viewing area $\geq 60\%$ of center lightness(Lens correction Shading [Turn on])	A
3	Dust	No dust in the center viewing area; Border area according to the limit samples	A
4	Dead pixel	No in the viewing area.	A
5	Wound pixel 	I area: Blemish number $\leq 1$ II area: Blemish number $\leq 4$	B
6	Color	Color distortion ratio of center $\pm 15\%$	B
7	Gray Scale	Margin of two near scales' brightness $\geq 6$	B
8	Distortion	$< 1\%$	B
9	Flare	No flare in $45^\circ$ viewing angle; No ghost in full viewing angle	B

**QA Plan**

NO.	Item	Sampling frequency	Measure	Remark
Image and reliability item				
1	TV Line	AQL 0.65 II Class	Same as production	100% Inspection
2	Shading	AQL 0.65 II Class	Same as production	100% Inspection
3	Dust	AQL 0.65 II Class	Same as production	100% Inspection
4	Dead pixel	AQL 0.65 II Class	Same as production	100% Inspection
5	Wound pixel	AQL 1.5 II Class	Same as production	100% Inspection
6	Color	AQL 1.5 II Class	Same as production	100% Inspection
7	Gray Scale	AQL 1.5 II Class	Same as production	100% Inspection
8	Distortion	N=5,c=0 per batch	Same as production	Sampling by QA
9	Flare	N=5,c=0 per batch	Same as production	Sampling by QA
Appearance Check Items				
1	Top side of Lens	AQL 1.0 II Class	Same as production	100% Inspection
2	Screw glue	AQL 1.0 II Class	Same as production	100% Inspection
3	L1 Glass	AQL 1.0 II Class	Same as production	100% Inspection
4	Holder	AQL 1.5 II Class	Same as production	100% Inspection
5	Sealed glue	AQL 1.0 II Class	Same as production	100% Inspection
6	FPC/PCB	AQL 1.0 II Class	Same as production	100% Inspection
7	Connector	AQL 1.0 II Class	Same as production	100% Inspection
8	Gold finger	AQL 1.0 II Class	Same as production	100% Inspection
9	Stiffener	AQL 1.5 II Class	Same as production	100% Inspection
10	Double coated tapes	AQL 1.5 II Class	Same as production	100% Inspection
11	Protective film	AQL 1.5 II Class	Same as production	100% Inspection

Sample:

Referenced standard: GB/T 2828.1-2003/ISO 2859-1:1999 and ANSI/ASQC.4-1993 II

## Package Specification

### Packaging Design One

Product No.	CM8078-A300BA-E	Release date							
Product name	Compact Camera Module	Releaser							
Supplier	TRULY SEMI CONDUCTORS LTD	Recycle	<input type="checkbox"/> YES <input checked="" type="checkbox"/> NO						
Quantity/ each box	TBD	Material for box	<input checked="" type="checkbox"/> paper <input type="checkbox"/> plastic						
Outer carton box size	405mm*290mm*290mm	Box type	<input checked="" type="checkbox"/> new <input type="checkbox"/> update						
Quantity / inner box * Quantity / outer box	TBD	Weight	<table border="1"> <tr> <td>g / pcs</td> <td>BOX=TYPE</td> <td>TBD</td> </tr> <tr> <td>Kg / outer box</td> <td>Record of SRF Dept.</td> <td>Kg(Max)</td> </tr> </table>	g / pcs	BOX=TYPE	TBD	Kg / outer box	Record of SRF Dept.	Kg(Max)
g / pcs	BOX=TYPE	TBD							
Kg / outer box	Record of SRF Dept.	Kg(Max)							

#### Packing Standards:

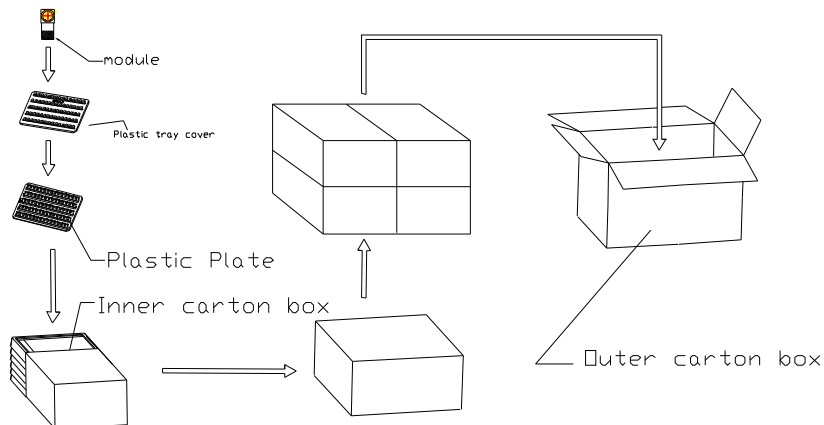

There are TBD modules each plastic plate.

There are TBD modules each inner carton box..

There are 4 each outer carton box.

#### Requirements of outer carton box :

1. Weight(Max): TBD Kg
2. Height (Max): 0.29 M
3. Prohibition: Box made by log

#### Material for Plastic tray

It is made of antistatic polystyrene which has no chemical pollution. Surface resistivity :  $10^6$  ohm/sq

## Packaging Design Two

Product No.	CM8078-A300BA-E	Release date	
Product name	Compact Camera Module	Releaser	
Supplier	TRULY SEMI CONDUCTORS LTD	Recycle	<input type="checkbox"/> YES <input checked="" type="checkbox"/> NO
Quantity/ each box	TBD	Material for box	<input checked="" type="checkbox"/> paper <input type="checkbox"/> plastic
Outer carton box size	405 mm *280 mm *170 mm	Box type	<input checked="" type="checkbox"/> new <input type="checkbox"/> update
Quantity / inner box * Quantity / outer box	TBD	Weight	BOX-TYPE Record of SRF Dept.
		ht	TBD Kg(Max)
		g / pcs Kg / outer box	

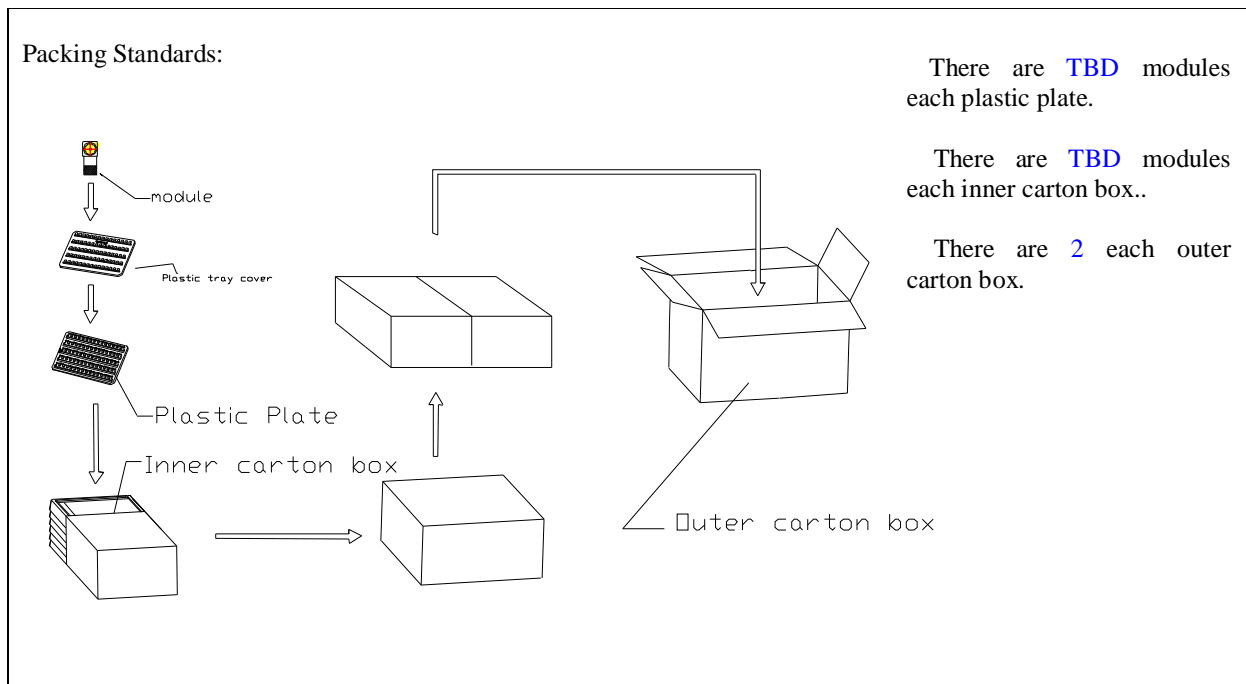

### Requirements of outer carton box :

4. Weight(Max): **TBD** Kg
5. Height (Max): 0.17 M
6. Prohibition: Box made by log

### Material for Plastic tray

It is made of antistatic polystyrene which has no chemical pollution. Surface resistivity :  $10^6$  ohm/sq

**PRIOR CONSULT MATTER**

- 1.①For Truly standard products, we keep the right to change material, process for improving the product property without notice on our customer.  
②For OEM products, if any change needed which may affect the product property, we will consult with our customer in advance.
2. If you have special requirement about reliability condition, please let us know before you start the test on our samples.

**FACTORY CONTACT INFORMATION**

**FACTORY NAME:** TRULY SEMICONDUCTORS LTD.

**FACTORY ADDRESS:** Truly Industrial Area, ShanWei City, GuangDong, China

**FACTORY PHONE:** 86-0660-3380061    **FAX:** 86-0660-3371772