

PRODUCT : CAMERA MODULE
MODEL NO. : CM4302-B030SF-E-V1
SUPPLIER : TRULY OPTO-ELECTRONICS LTD.
DATE : July 9, 2009



CERT. No. 946535
ISO9001
TL9000

SPECIFICATION

Revision: 1.0

CM4302-B030SF-E-V1

If there is no special request from customer, TRULY OPTO-ELECTRONICS LTD. will not reserve the tooling of the product under the following conditions:
1. There is no response from customer in two years after TRULY OPTO-ELECTRONICS LTD submit the samples;
2. There is no order in two years after the latest mass production.
And correlated data (include quality record) will be reserved one year more after tooling was discarded.

TRULY OPTO-ELECTRONICS LTD: **CUSTOMER:**

Quality Assurance Department: _____
Approved by:
Technical Department: _____

Approved by:

CONTENTS

- n KEY INFORMATION
- n PIN ASSIGNMENT
- n ELECTRICAL CHARACTERISTICS
- n MECHANICAL DRAWING
- n APPEARANCE SPECIFICATION
- n IMAGE SPECIFICATION
- n QA PLAN
- n PRECAUTIONS FOR USING CCM MODULES
- n PACKAGE SPECIFICATION
- n PRIOR CONSULT MATTER
- n FACTORY CONTACT INFORMATION

WRITTEN BY	CHECKED BY	APPROVED BY
HUANG WEI NA	WEI YOU XING	LIU TIE NAN

Key Information

Module No.		CM4302-B030SF-E-V1
Module Size		8.25mm x 6.5mm x 4.35mm
Image Quality		≥200 TV line
Sensor Type		YACBAA0SDDAS
Array Size		640 X 480(VGA)
Power Supply		2.8V/1.8V
Lens		1/10 inch 2Plastic+IR
Focus(F.NO)		2.4
View Angle		56.1°
Image Area		2.36mm x 1.76mm
Object distance		20cm-infinity
ADC		10 bit
Pixel size		2.25um x 2.25um
IR Cutter		650+/-10nm
Sensor Temperature Range	Operation	-20° C to 60° C
	Stable Image	-30° C to 80° C
Output Formats		.YUV 4:2:2 .RGB 5:6:5 RGB 4:4:4
Frame Rate		30 fps for VGA
Power Consumption		TBD
Color Filter		RGB Bayer
Sub -Sample		1/4(QVGA)
Substrate		PCB
Master Clock		24MHz(Max)
IC Package		34pin W-CSP
Package		Antistatic Plastic

Pin Assignment

No.	Name	Pin type	Description
1	NC		
2	AGND	Power	Analog Ground
3	SIO_D	I/O	Data for two-wire serial interface
4	AVDD	Power	Analog power supply
5	SIO_C	Input	Clock for two-wire serial interface
6	RESET	Input	RESET initializes sensor. Active Low
7	VSYNC	Output	Vertical Synchronization
8	PWDN	Input	CHIP_ENABLE enables sensor. Active high
9	HREF	Output	Horizontal Synchronization
10	DVDD	Power	Digital Core Circuit Power Supply Voltage
11	DOVDD	Power	I/O Power Supply Voltage
12	Y7	Output	Image Data[7]
13	XCLK	Input	Master Clock
14	Y6	Output	Image Data [6]
15	DGND	Power	Digital Ground
16	Y5	Output	Image Data [5]
17	PCLK	Output	PCLK synchronizes D[7:0]
18	Y4	Output	Image Data [4]
19	Y0	Output	Image Data [0]
20	Y3	Output	Image Data [3]
21	Y1	Output	Image Data [1]
22	Y2	Output	Image Data [2]
23	NC		
24	NC		

Electrical Characteristics

1. Absolute Maximum Ratings

Item	Symbol	Min	Max	Note
Digital Core Power	$V_{DD:C}$	-0.3V	2.3 V	7
Analog and Pixel Power	$V_{DD:A}$ & $V_{DD:P}$	-0.3V	3.3V	7
Digital I/O Power	$V_{DD:I}$	-0.3V	3.3V	7
Input Pin Voltage	V_{IN}	-0.2V	$V_{DD:I}$	7
Output Pin Voltage	V_{OUT}	-0.2V	$V_{DD:I}$	7

Note7) Exposure to absolute maximum rating conditions for extended periods may affect reliability.

2.DC Characteristics

Item	Symbol	Min	Typ	Max	Unit	Note
Digital Core Circuit Power Supply Voltage	$V_{DD:D}$	1.7	1.8	1.9	V	
Analog Circuit Power Supply Voltage	$V_{DD:A}$	2.6	2.8	3.0	V	
Analog Pixel Circuit Power Supply Voltage	$V_{DD:P}$	2.6	2.8	3.0	V	
Digital I/O Circuit Power Supply Voltage	$V_{DD:I}$	1.7	1.8/2.8	3.0	V	
H level Input Voltage	V_{IH}	$0.7 \cdot V_{DD:I}$			V	
L level Input Voltage	V_{IL}			$0.3 \cdot V_{DD:I}$	V	
Output High Current ($V_{DD:I} = 2.8V, V_{OH} = 2.4V$)	I_{OH}		7		mA	1
Output High Current ($V_{DD:I} = 1.8V, V_{OH} = 1.4V$)	I_{OH}		4		mA	1
Output Low Current ($V_{DD:I} = 2.8V, V_{OH} = 0.4V$)	I_{OL}		9		mA	1
Output Low Current ($V_{DD:I} = 1.8V, V_{OH} = 0.4V$)	I_{OL}		6		mA	1

Note1) User can control the amount of current by controlling bit[7:4] of PWRCTL[0x01:P0].

Above values are output current when bit[7:4] of PWRCTL[0x01:P0] is 4'b0101.

3. AC Characteristics of Two Wire Serial Bus

Parameter	Symbol	Min.	Typ.	Max.	Unit
SC frequency	f_{sck}			400	KHz
SC low period	t_{lo}	1.2		-	us
SC high period	t_{hi}	0.6		-	us
SC setup time for START condition	t_{st1}	0.6		-	us
SC setup time for STOP condition	t_{st3}	0.6		-	us
SC hold time for START condition	t_{hd1}	0.6		-	us
SD setup time	t_{st2}	0.6		-	us
SD hold time	t_{hd2}	0.6		-	us
Bus free time Between a STOP and START condition	t_{bur}	0.6		-	us
Rising time of both SD and SC	t_r	-		0.3	us
Falling time of both SD and SC	t_f	-		0.3	us
Capacitive load of SC/SD	C_D	-		200	pF
Pull-up resistor on SC and SD			1.5		k Ω

Note: For more information of sensor please refer to the YACBAA0SDDAS specification.

ROHS

CM4302-B030SF-E-V1 Camera Module

Customer No.:

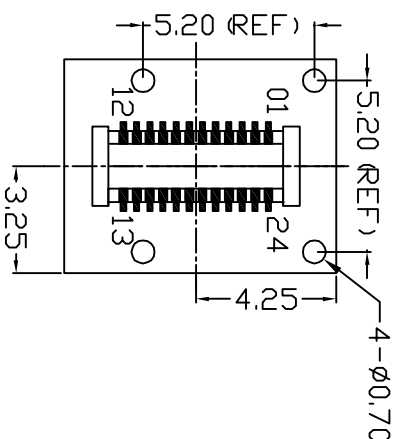
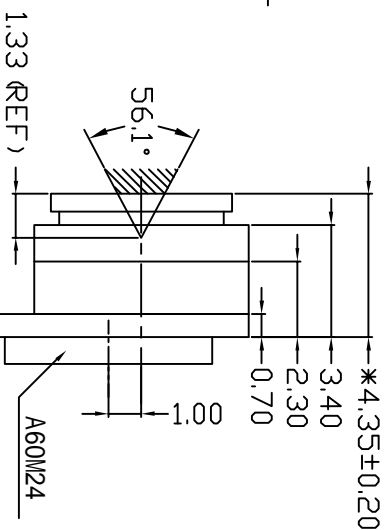
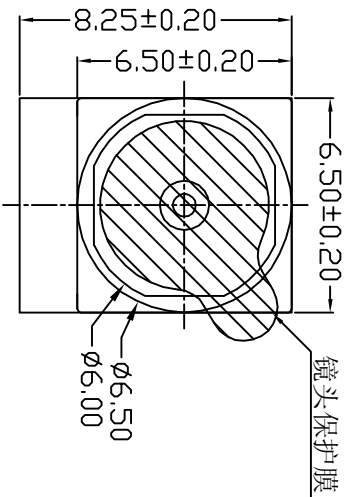

PIN NO	NAME
1	NC
2	AGND
3	SI0D
4	AVDD 2.8V
5	SI0C
6	RESET
7	VSYN
8	PW/DN
9	HREF
10	DVDD 1.8V
11	DDVDD 2.8V
12	Y7
13	XCLK
14	Y6
15	DGND
16	Y5
17	PCLK
18	Y4
19	Y0
20	Y3
21	Y1
22	Y2
23	NC
24	NC

主要参数 (Module Specification)

焦距 (EFL)	1.65 mm
光圈 (F. NO)	2.4
视场角 (View Angle)	56.1°
畸变 (Distortion)	< 1 %
解象力 (Image Quality)	≥ 200 TV Line
景深 (Focusing Range)	20 cm ~ Infinity
感光芯片 (Chip Type)	YACBA0SDAS
像素 (Array Size)	0.3M
镜头类型 (Lens Size)	1/10 INCH 2P+1R

- 备注:
1. 带* 尺寸为关键尺寸;
 2. 未标注圆角为R0.2.

CUSTOMER APPROVE		AMEND		手机摄像头模组	
Mechanical	Electrical			TOLERANCE DECIMAL	PRDUCT NO.
△	△			.x ± .30	CM4302-B030SF-E-V1
△	△			.xx ± .20	D/VN 杨永超 20090702
△	△			≤ ± 1/4'	DSN 杨永超 20090702
ND.		CONTENT	DATE		CHKD 赖路平 20090702
					APPD 刘铁楠 20090702
					DRAY NO. REV A
					TRULY SEMICONDUCTORS LTD.

NDT IN SCALE UNIT mm SHEET:

Appearance Specification

NO.	Item	Standard	Importance Class
1	Top side of Lens	No obvious impurity and oil impurity on the front of lens within the half area; The defect(unfeeling) limitation: width \leq 1mm, length \leq 2mm, the defect number \leq 2; No feeling defect; The width of defects and gaps on the outside of Lens \leq 0.3mm. Others are unlimited.	A
2	Screw glue	Normally screw glue shall be symmetrical distributed around lens circle side. Particular circs, glue distribution must not disturb customer's assembly operation.	A
3	L1 Glass	No defect and dust check from 45° angle under the reflexing light and from 0° under the highlight	A
4	Holder	No obvious impurity and distortion of outline. The width and length of defect is unlimited, the depth \leq 0.1mm and \leq 1/4 of the thickness of Holder.	B
5	Sealed glue	Sealed glue distributing between holder and FPC must be symmetrical and smooth. Not allow glue leakage and asymmetric thickness. After holder assembly, the thickness distance between one side and its opposite side shall be less than 0.2mm. Excess glue over the holder shall not make the outside dimension be out of control.	A
6	FPC/PCB	Edge defect limitation: width \leq 1/2H (H is minimum.)、 length \leq 1mm、 defect numbers per edge \leq 2(No tearing gap inby edge for FPC); Edge outshoot limitation (width \leq 0.3mm, length \leq 1mm). No obvious impurity and crease on the surface. If there was shield film on the surface, the spot size of the film shall be less than 0.3mm \times 1mm and no line is exposed. If it was not be cleaned and did not influence the total thickness, it would be permitted. Label and mark shall be clear enough to be discerned.	A
7	Connector	No dust, fingerprint, and not allows to turning colors, distortion; Solder must be well; No open circuit or short circuit	A

8	Gold finger	No dust, fingerprint, and not allows to turning colors, burned, unsmoothed and peeled; No open circuit or short circuit; The defect width shall be smaller than 20% of gold finger's width. No copper/nickel exposed in defect. Numbers of defected pin shall be less than 3. The defect limitation:width \leq 0.08mm,length \leq 5mm.	A
9	Stiffener	Holder anchor pole length overtopping the steel plate shall be less than 0.2mm. No dust, rust and deep scratch on the steel surface without Double coated tapes.	B
10	Double coated tapes	Adhered direction shall be right. Not allows to excess steel plate edge. No alveoli and stick. Not allows to peel glue and rip protective paper when tear the protective paper.	B
11	Protective film	No dust in the glue side. Not allows to float or drop. Adhered direction shall be right.	B

Remark:

1. The definition of the appearance importance class

- A: The defect can be found in the finished product, or have obvious visual differences from good products, such as crack, defect and dust, or influence image quality, or are appointed by the customer. We will emphasize these items and check all products.
- B: The defect can be found in the finished product and has visual difference from the good one, but will not affect customer's aesthetic judgement. Or the defect can not be found in the finished product and will not generate functional problem, but will slightly influence sequential manufacture process or condition. We will supervise these items in the manufacturing process and check products selectively.

2. Sampling standard

Referenced standard: GB/T 2828.1-2003/ISO 2859-1:1999 and ANSI/ASQC.4-1993 II

Image Specification

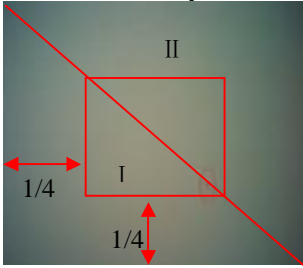
NO.	Item	Standard	Important Class
1	TV Line	Center \geq 300 8 point of 0.7 viewing field \geq 200	A
2	Shading	The lightness of 90% viewing area \geq 40% of center lightness(Lens correction Shading [Turn off]); The lightness of 90% viewing area \geq 60% of center lightness(Lens correction Shading [Turn on])	A
3	Dust	No dust in the center viewing area; Border area according to the limit samples	A
4	Dead pixel	No in the viewing area.	A
5	Wound pixel 	I area: Blemish number \leq 2 II area: Blemish number \leq 6	B
6	Color	Color distortion ratio of center \pm 15%	B
7	Gray Scale	Margin of two near scales' brightness \geq 6	B
8	Distortion	$<$ 1%	B
9	Flare	No flare in 45° viewing angle; No ghost in full viewing angle	B

QA Plan

NO.	Item	Sampling frequency	Measure	Remark
Image and reliability item				
1	TV Line	AQL 0.65 II Class	Same as production	100% Inspection
2	Shading	AQL 0.65 II Class	Same as production	100% Inspection
3	Dust	AQL 0.65 II Class	Same as production	100% Inspection
4	Dead pixel	AQL 0.65 II Class	Same as production	100% Inspection
5	Wound pixel	AQL 1.5 II Class	Same as production	100% Inspection
6	Color	AQL 1.5 II Class	Same as production	100% Inspection
7	Gray Scale	AQL 1.5 II Class	Same as production	100% Inspection
8	Distortion	N=5,c=0 per batch	Same as production	Sampling by QA
9	Flare	N=5,c=0 per batch	Same as production	Sampling by QA
Appearance Check Items				
1	Top side of Lens	AQL 1.0 II Class	Same as production	100% Inspection
2	Screw glue	AQL 1.0 II Class	Same as production	100% Inspection
3	L1 Glass	AQL 1.0 II Class	Same as production	100% Inspection
4	Holder	AQL 1.5 II Class	Same as production	100% Inspection
5	Sealed glue	AQL 1.0 II Class	Same as production	100% Inspection
6	FPC/PCB	AQL 1.0 II Class	Same as production	100% Inspection
7	Connector	AQL 1.0 II Class	Same as production	100% Inspection
8	Gold finger	AQL 1.0 II Class	Same as production	100% Inspection
9	Stiffener	AQL 1.5 II Class	Same as production	100% Inspection
10	Double coated tapes	AQL 1.5 II Class	Same as production	100% Inspection
11	Protective film	AQL 1.5 II Class	Same as production	100% Inspection

Sample:

Referenced standard: GB/T 2828.1-2003/ISO 2859-1:1999 and ANSI/ASQC.4-1993 II

PRECAUTIONS FOR USING CCM MODULES

Handling Precautions

- DO NOT try to open the unit enclosure as there is no user-serviceable component inside. To prevent damage to the camera module by electrostatic discharge, handling the camera module only after discharging all static electricity from yourself and ensuring a static-free environment for the camera module.
- DO NOT touch the top surface of the lens.
- DO NOT press down on the lens.
- DO NOT try to focus the lens.
- DO NOT put the camera module in a dusty environment.
- To reduce the risk of electrical shock and damage to the camera module, turn off the power before connect and disconnect the camera module.
- DO NOT drop the camera module more than 60 cm onto any hard surface.
- DO NOT expose camera module to rain or moisture.
- DO NOT expose camera module to direct sunlight.
- DO NOT put camera in a high temperature environment.
- DO NOT use liquid or aerosol cleaners to clean the lens.
- DO NOT make any changes or modifications to camera module.
- DO NOT subject camera module to strong electromagnetic field.
- DO NOT subject the camera module to excessive vibration or shock.
- DO NOT Impact or nip CCM module with spiculate things
- DO NOT alter, modify or change the shape of the tab on the metal frame.
- DO NOT make extra holes on the printed circuit board, modify its shape or change the positions of components to be attached.
- DO NOT damage or modify the pattern writing on the printed circuit board.
- Absolutely DO NOT modify the zebra rubber strip (conductive rubber) or heat seal connector
- Except for soldering the interface, DO NOT make any alterations or modifications with a soldering iron.
- DO NOT twist FPC of CCM.

Precaution for assemble the module with ZIF connector:

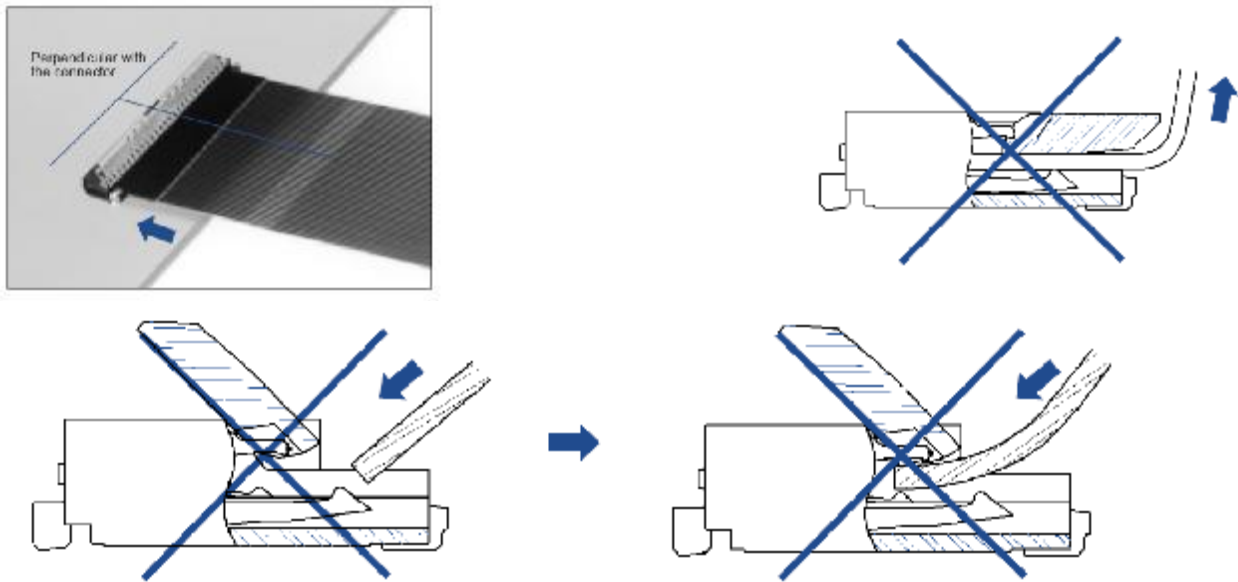

Precaution for soldering the CCM:

	Manual soldering	Machine drag soldering	Machine press soldering
No ROHS product	290°C ~350°C. Time: 3-5S.	330°C ~350°C. Speed: 4-8 mm/s.	300°C ~330°C. Time: 3-6S. Press: 0.8~1.2Mpa
ROHS product	340°C ~370°C. Time: 3-5S.	350°C ~370°C. Speed: 4-8 mm/s.	330°C ~360°C. Time: 3-6S. Press: 0.8~1.2Mpa

- (1) If soldering flux is used, be sure to remove any remaining flux after finishing to soldering operation. (This does not apply in the case of a non-halogen type of flux.) It is recommended that you protect the lens surface with a cover during soldering to prevent any damage due to flux spatters.
- (2) The CCM module and board should not be detached more than three times. This maximum number is determined by the temperature and time conditions mentioned above, though there may be some variance depending on the temperature of the soldering iron.

Other precautions

For correct using please refer to the relative criterions of electronic products.

Limited Warranty

Unless agreed between TRULY and customer, TRULY will replace or repair any of its CCM modules which are found to be functionally defective when inspected in accordance with TRULY CCM acceptance standards for a period of one year from date of shipments. Cosmetic/visual defects must be returned to TRULY within 90 days of shipment. Confirmation of such date shall be based on freight documents. The warranty liability of TRULY limited to repair and/or replacement on the terms set forth above. TRULY will not be responsible for any subsequent or consequential events.

Return CCM under warranty

No warranty can be granted if the precautions stated above have been disregarded. The typical examples of violations are:

- Holder is apart from module.
- Holder or Connector is anamorphic.
- Connector is turnup.
- FPC is lacerated or disconnection, and so on.

Module repairs will be invoiced to the customer upon mutual agreement. Modules must be returned with sufficient description of the failures or defects. Any connectors or cable installed by the customer must be removed completely without damaging the PCB eyelet, conductors and terminals.

Package Specification

Packaging Design One

Product No.	CM4302-B030SF-E-V1	Release date							
Product name	Compact Camera Module	Releaser							
Supplier	TRULY OPTO-ELECTRONICS LTD	Recycle	<input type="checkbox"/> YES <input checked="" type="checkbox"/> NO						
Quantity/ each box	TBD	Material for box	<input checked="" type="checkbox"/> paper <input type="checkbox"/> plastic						
Outer carton box size	405mm*290mm*290mm	Box type	<input checked="" type="checkbox"/> new <input type="checkbox"/> update						
Quantity / inner box * Quantity / outer box	TBD	Weight	<table border="1"> <tr> <td>g / pcs</td> <td>BOX=TYPE</td> <td>TBD</td> </tr> <tr> <td>Kg / outer box</td> <td>Record of SRF Dept.</td> <td>Kg(Max)</td> </tr> </table>	g / pcs	BOX=TYPE	TBD	Kg / outer box	Record of SRF Dept.	Kg(Max)
g / pcs	BOX=TYPE	TBD							
Kg / outer box	Record of SRF Dept.	Kg(Max)							

Packing Standards:

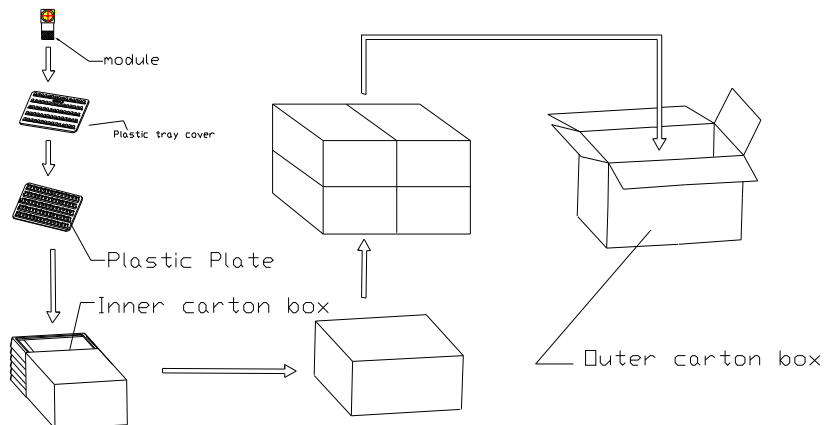

There are TBD modules each plastic plate.

There are TBD modules each inner carton box..

There are 4 each outer carton box.

Requirements of outer carton box :

1. Weight(Max): TBD Kg
2. Height (Max): 0.29 M
3. Prohibition: Box made by log

Material for Plastic tray

It is made of antistatic polystyrene which has no chemical pollution. Surface resistivity : 10^6 ohm/sq

Packaging Design Two

Product No.	CM4302-B030SF-E-V1	Release date					
Product name	Compact Camera Module	Releaser					
Supplier	TRULY OPTO-ELECTRONICS LTD	Recycle	<input type="checkbox"/> YES <input checked="" type="checkbox"/> NO				
Quantity/ each box	TBD	Material for box	<input checked="" type="checkbox"/> paper <input type="checkbox"/> plastic				
Outer carton box size	405 mm *290 mm *170 mm	Box type	<input checked="" type="checkbox"/> new <input type="checkbox"/> update				
Quantity / inner box * Quantity / outer box	TBD	Weig ht	<table border="1"> <tr> <td>g / pcs</td> <td rowspan="2">BOX-TYPE Record of SRF Dept.</td> <td rowspan="2">TBD Kg(Max)</td> </tr> <tr> <td>Kg / outer box</td> </tr> </table>	g / pcs	BOX-TYPE Record of SRF Dept.	TBD Kg(Max)	Kg / outer box
g / pcs	BOX-TYPE Record of SRF Dept.	TBD Kg(Max)					
Kg / outer box							

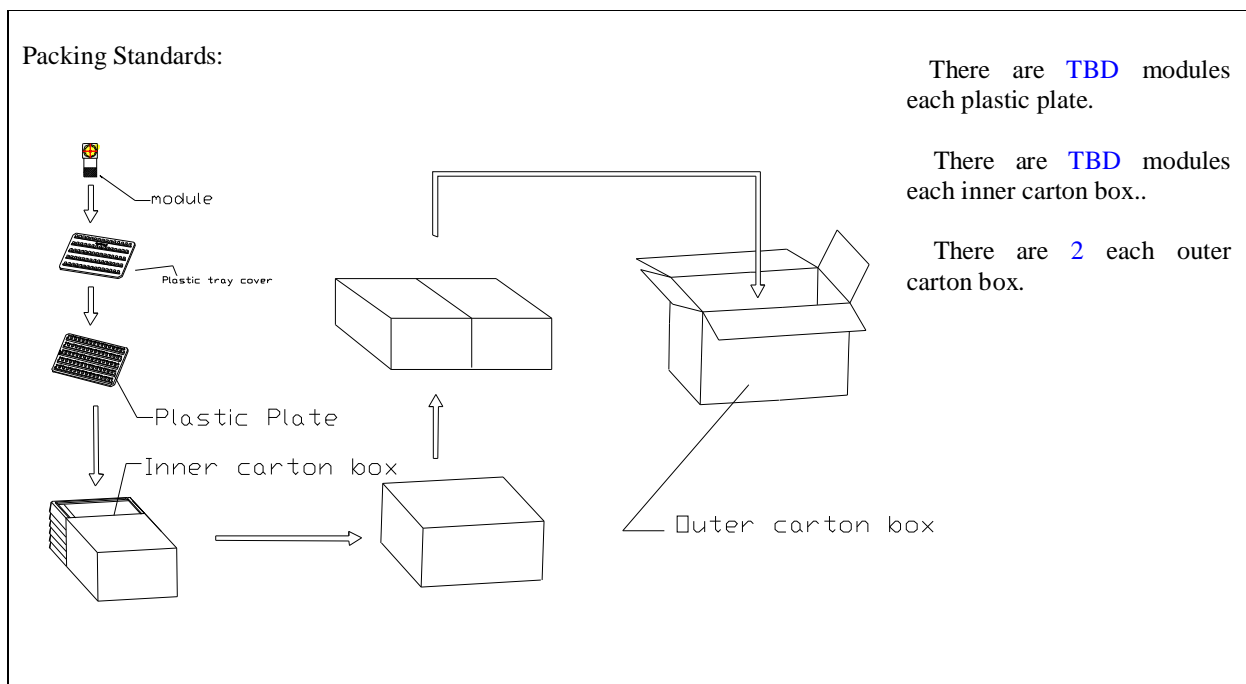

Requirements of outer carton box :

4. Weight(Max): TBD Kg
5. Height (Max): 0.17 M
6. Prohibition: Box made by log

Material for Plastic tray

It is made of antistatic polystyrene which has no chemical pollution. Surface resistivity : 10^6 ohm/sq

PRIOR CONSULT MATTER

- 1.①For Truly standard products, we keep the right to change material, process for improving the product property without notice on our customer.
②For OEM products, if any change needed which may affect the product property, we will consult with our customer in advance.
2. If you have special requirement about reliability condition, please let us know before you start the test on our samples.

FACTORY CONTACT INFORMATION

FACTORY NAME: TRULY OPTO-ELECTRONICS LTD

FACTORY ADDRESS: Truly Industrial Area, ShanWei City, GuangDong, China

FACTORY PHONE: 86-0660-3380061 **FAX:** 86-0660-3371772