

PRODUCT : CAMERA MODULE**MODEL NO.** : CP8171-D130BF-E**SUPPLIER** : TRULY SEMICONDUCTORS LTD.**DATE** : May 15, 2009

CERT. No. 946535
 ISO9001
 TL9000

SPECIFICATION

Revision: 0.1

CP8171-D130BF-E

If there is no special request from customer, TRULY SEMICONDUCTORS Co., Ltd will not reserve the tooling of the product under the following conditions:
 1. There is no response from customer in two years after TRULY SEMICONDUCTORS Co., Ltd submit the samples;
 2. There is no order in two years after the latest mass production.
 And correlated data (include quality record) will be reserved one year more after tooling was discarded.

TRULY SEMICONDUCTORS LTD: **CUSTOMER:**

Quality Assurance Department: _____
 Approved by: _____
 Technical Department: _____

Approved by: _____

CONTENTS

- n GENERAL DESCRIPTION
- n KEY INFORMATION
- n PIN ASSIGNMENT
- n ELECTRICAL CHARACTERISTICS
- n MECHANICAL DRAWING
- n APPEARANCE SPECIFICATION
- n IMAGE SPECIFICATION
- n QA PLAN
- n PRECAUTIONS FOR USING CCM MODULES
- n PACKAGE SPECIFICATION
- n PRIOR CONSULT MATTER
- n FACTORY CONTACT INFORMATION

WRITTEN BY	CHECKED BY	APPROVED BY
LI JING	WEI YOU XING	LIU TIE NAN

General Description

Truly's camera module for notebook 1.3MP is a 1.3 Mega-Pixel, USB 2.0 high-speed camera module designed to provide high quality colorful videos and still images, for instant visual communication applications on a notebook platform. The camera module is a sensor on board module designed for notebook application where low power consumption and small size are of utmost importance. It combines the CMOS sensor and platform for high quality camera products.

◆. SN9C233AJG Feature

SN9C233 is a USB 2.0 compatible PC Camera controller. The built-in extreme low-power transceiver provides the superior compatibility with various USB host and the best quality for image applications. It is fully compliant with USB Video Class. With the integrated sensor interface and color processing engine, it can support most VGA and SXGA CMOS SOC sensors.

1. System

- 3.3V single power supply, 1.8V Core (generated by internal regulator) and 3.3V I/O
- Extreme low power consumption, <38mA when standby and <400uA when suspend (Power consumption of sensor is not included)
- Built-in PLL for internal clock generation with input crystal frequency of 12Mhz
- Using external serial flash to store customized code and data
- No external RAM needed
- 46-pin QFN package is available; please see later section for more detail.

2. USB Controller

- USB 2.0 compatible
- USB Video Class 1.1 compliant (Additional FW routines are required)
- USB 2.0 HS/FS auto sense and switch
- USB FS mode and USB disconnection are programmable
- 3 endpoints: CONTROL pipe, Interrupt IN and Isochronous-IN (video, 24MB/s max)
- 6 alternate setting for video streaming interface

3.0 Sensor Interface

- Support VGA and SXGA COMS ISP sensor
- Support YUY2 image data format from sensor
- Up to 24Mhz output clock for clock request of CMOS sensor silicon.
- Up to 48Mhz pixel clock is acceptable
- Support industrial standard 2-wire serial interface for sensor control

4.0 Image Pre-processing

- Configurable windowing function after sensor output

5.0 Color Processing

- Programmable gamma table for Y channel
- Configurable windowing function after processed image

6.0 Scaling Engine

- 1/2,1/4 smooth scaling for VGA input
- 3/5,4/5 second linear scaling for VGA input

7.0 Video/Still Image

- Output video/still image format
USB Video Class Uncompressed YUY2 payload(16 bit/pixel)
- Video streaming up to 30fps@VGA or [8.5fps@SXGA](#) at USB2.0 high-speed mode.
- Still image capture support UVC still image capture method 0/1/2

8.0 Frame Rate

- Frame rate considering USB bandwidth limitation

High-speed mode						
Output format	SXGA	VGA	CIF	QVGA	QCIF	QQVGA
YUY2	8.5fps	30fps	30fps	30fps	30fps	30fps

- Frame rate depends on sensor characteristic
The maximum frame rate is limited by how many frame per second that sensor can output under 48MHz pixel clock and is limited on High-Speed USB ISO bandwidth 24MB/s.

9.0 GPIO

- 4 GPIO are available, predefined as LED control, sensor reset pin(or snapshot button)and image flip detection.

10.0 Micro Controller and USB Device Feature

- Built-in 8032 micro controller with 3K bytes data memory ,and maximum CPU clock rate is 24Mhz
- Total 64K bytes code memory include 56K bytes mask ROM and 8K bytes SRAM
- Load extended 28KB F/W from external serial flash.
- Load VID/PID, manufacture, product and serial number string from external serial flash.
- Load UVC parameter definition from external serial flash.
- F/W is upgradeable from PC
- Force USB disconnect
- Interrupt at the end of H/W windowing
- CPU watch dog

11.0 Pre-defined Function for USB Video Class

- Brightness control(UVC defined)
- Contrast control(UVC defined)
- Hue control(UVC defined)
- Saturation control(UVC defined)
- Sharpness control(UVC defined)
- Gamma control(UVC defined)
- Privacy control(UVC defined)
- Image auto-flip control triggered by GPIO
- Extension unit support

12.0 Platform Support

- Microsoft Window XP 32bit SP2,Microsoft Window XP 64bit,Microsoft Windows Vista 32bit,Microsoft Windows 64bit
- Mac-OS X 10.4.8 or later
- Linux with UVC driver

Block Diagram

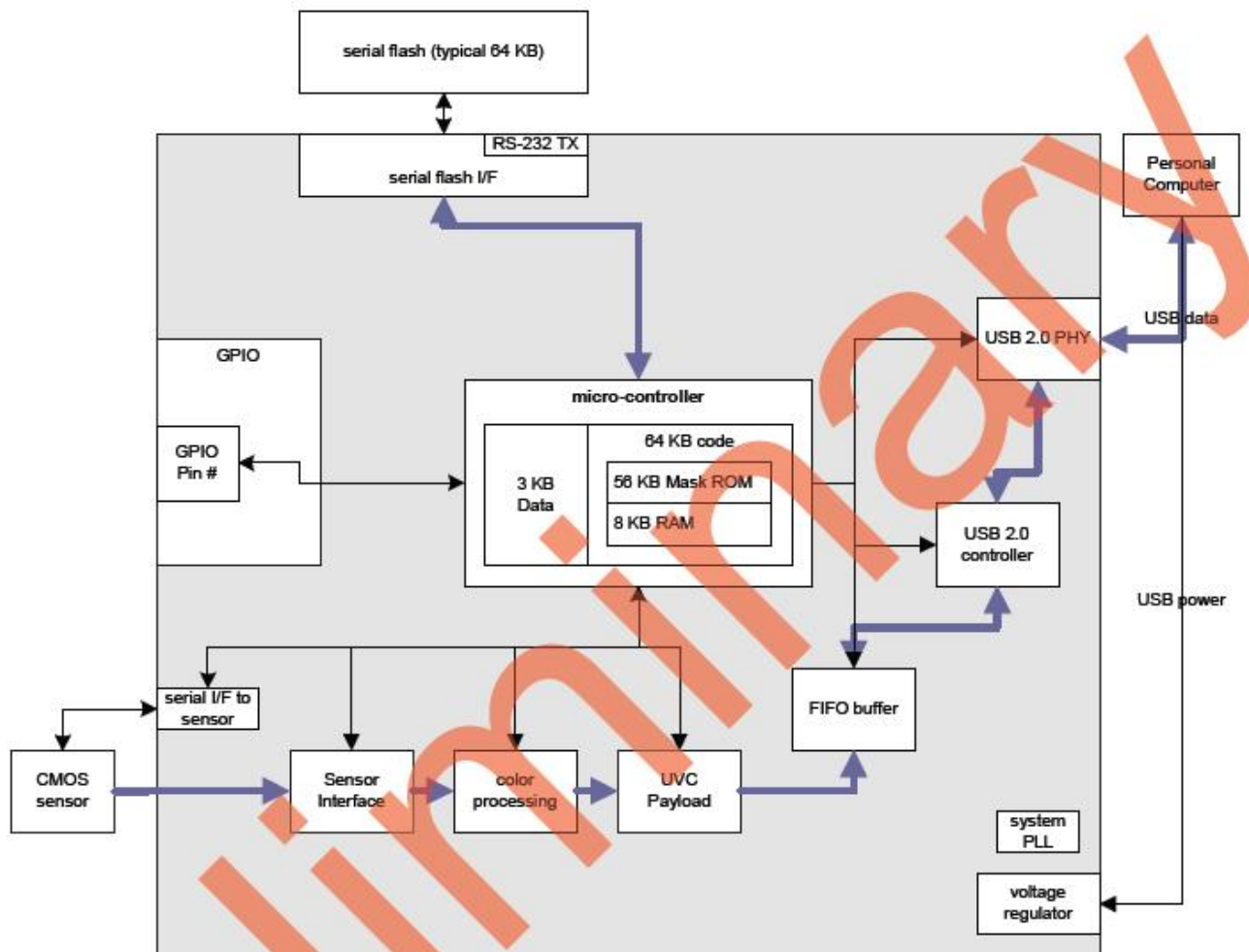

◆. S5K6AAFx Feature

The S5K6AAFx is a highly integrated 1.3Mp camera chip that includes a CMOS image sensor, an image processor and both 8-bit ITU-R 656/601 parallel interface and MIPI CSI2 compliant serial interface. It is fabricated by the SAMSUNG 0.13 μ m CMOS image sensor process developed for imaging applications to realize highefficiency and low-power photo sensor.

The CMOS image sensor consists of the 1284x1028 Active Pixel Sensor (APS) array, which has a 1/6-inch optical format, on-chip 10-bit ADC array to digitize the analog pixel output, and on-chip Correlated Double Sampling (CDS) to reduce Fixed Pattern Noise (FPN) drastically.

The image processor performs sophisticated image processing functions, including color recovery and correction, false color suppression, lens shading correction, noise removal, edge enhancement, programmable gamma correction, image down scaling, auto defect correction, auto dark level compensation, auto flicker correction (50/60Hz), auto exposure (AE), auto white balance (AWB). The auto functions are performed by F/W on an embedded RISC processor. The host controller is able to access and control this device via general IIC bus.

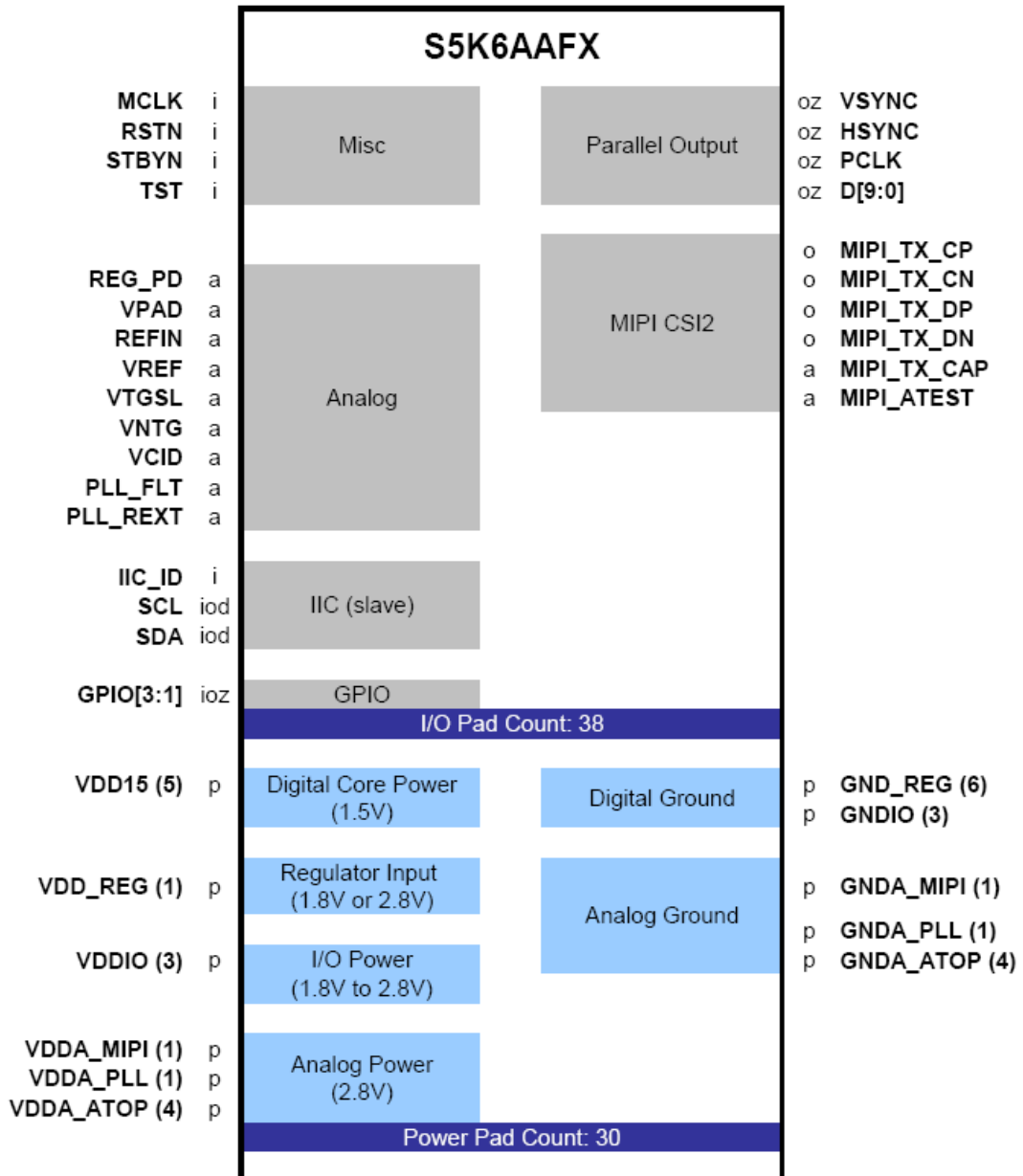

Key Information

Camera Module No. CP8171-D130BF-E			
Camera Module	Module Size		60.0mm x 8.0mm x 3.7mm
	Resolution		≥400 TV line (@0.7Field)
	Input Supply Power		5V ± 5%
	Driver On Current		TBD mA
	Video Streaming Current		TBD mA
	Suspend Current		TBD μA
	Focal Range		40cm-infinity
	Temperature Range	Operation	-20° C to 70° C
		Stable Image	0° C to 50° C
Application Area		Notebook,UMPC,Netbook,PC MID etc.	
DSP	DSP Type		SN9C233AJG (Controller IC for NB Embedded)
	Support Sensor		up to 1.3Mega CMOS Sensor
	Frame Rate	VGA	30fps
		SXGA	8.5fps
	Campture Still Image Size		Up To 1.3M Pixel Resolution
	Compatibility		USB 2.0 Compliant,Microsoft WHQL Certified USB Video Class 1.1
	OS Supported		Windows XP(with service pack 2)&Vista
	Power Supply Voltage	Core	1.8V(1.62V to 1.98V)
		I/O	3.3V(3.0V to 3.6V)
	Output Video Fromat		YUY2(16bits/pixel)
	Suspend Supply Current		<400μA
	Package		48-Pin Tiny QFN at 6.5mmx5mmx0.85mm
	Clock		TBD
	UVC		Support
Image Reverse		Support(Flip and Mirror)	
SENSOR	Sensor Type		S5K6AAFX
	Array Size		1284 X 1028
	Power supply	Analog	2.8V
		Digita Core	1.5V
		I/O	1.8V or 2.8V
	Image Area		2.247mm*1.80mm
	Sensitivity		600 mV/(Lux.sec)
	S/N Ratio		38.3 dB
	Dynamic Range		>60 dB
	Power requirement	Active	TBD
		Standby	TBD
	Output Formats		YUV422,RGB565,RGB888,RAW10
Dark current		<5 Mv/sec	
Pixel size		1.75μm x 1.75μm	
LENS	EFL		2.28mm
	F.NO		2.4 ± 5%
	FOV(Max/D/H/V)		68.6° /64.2° /52° /42.5°
	TV Distortion		<1%
	Construction		3Plastic+ IR(650+/-10nm@50%)
	Focus		Fixed

Pin Assignment

No.	Name	Pin type	Description
1	USB-POWER (+5V)	Power Pin	USB power Input
2	USB-PADM (D-)	Data Pin	USB data Transmission
3	USB-PADP (D+)	Data Pin	USB data Transmission
4	GND	GND	Ground
5	SHIELD GND	GND	SHIELD ground

Electrical Characteristics

◆ S5K6AFX Characteristics

1. Absolute Maximum Ratings

Parameter	Symbol	Value	Unit
I/O Digital Power (2.8V or 1.8V)	V_{DDIO}	-0.3 to 3.8	V
Analog Power (2.8V)	V_{DDA}	-0.3 to 3.8	
Core Digital Power (1.5V)	V_{DDD}	-0.3 to 2.0	
Input Voltage	V_I	-0.3 to 3.8	
Ambient Temperature	T_A	-20 to +60	°C
Storage Temperature	T_S	-40 to +85	

2. DC Characteristics (-30°C < T_a < 70°C)

($V_{DDIO1} = 2.8V \pm 0.2V$, $V_{DDIO2} = 1.8V \pm 0.15V$, $V_{DDD} = 1.5V \pm 0.1V$, $T_a = -20$ to $+60$ °C)

Parameter	Symbol	Condition	Min	Typ	Max	Unit
Supply Voltage	V_{DDA}		2.6	2.8	3.0	V
	V_{DDD}		1.40	1.5	1.60	
	V_{DDIO1}		2.6	2.8	3.0	
	V_{DDIO2}		1.65	1.8	1.95	
High-Level Input Voltage	V_{IH}		0.7* V_{DDIO}	-	-	V
Low-Level Input Voltage	V_{IL}		-	-	0.2* V_{DDIO}	
High Level Output Voltage	V_{OH}		$V_{DDIO}-0.2$	-	-	
Low-Level Output Voltage	V_{OL}		-	-	0.2	
High-Level Input Current	I_{IH}	$V_I = V_{DDIO}$	-10	-	10	µA
		$V_I = V_{DDIO}$ (with Pull-Down)	-	-	72	
Low-Level Input Current	I_{IL}	$V_I = V_{SS}$	-10	-	10	
		$V_I = V_{SS}$ (with Pull-Up)	-72	-	-	
Standby Current	I_{STBY}	STBYN = Low, MCLK = Low (0 lux Illumination)	-	35	200	
Supply Current (Digital)	I_{DDD}	Parallel Output Mode @15fps	-	110	120	

Parameter	Symbol	Condition	Min	Typ	Max	Unit
Supply Current (Analog)	I_{DDA}	Parallel Output Mode @15fps	-	35	45	
Supply Current (Analog)	I_{DDIO} (2)	Parallel Output Mode @15fps	-	35	45	
Power Consumption	P_{DD}	Parallel Output Mode @15fps	-	359	423	mW
Input Capacitance	C_{IN}		-	-	5	pF

[Notes]

(1) 2.8V input to regulator is not recommended due to increased power consumption.

(2) I_{DDIO} is affected by external PCB capacitance.

3. Imaging Characteristics

Parameter	Unit	Value	Remark
Effective resolution	pixel	1280 x 1024	
Active resolution	pixel	1284 x 1028	
Optical format	Inch	1/6	
Pixel size	Um	1.75um	
Shutter type	-	Electronic rolling shutter	
Full saturation	mV	>900	
ADC saturation	mV	750	
Sensitivity@Green	mV/lux.sec	600	
Dark current	mV/sec	<5	
Random noise	e-	3	
Dynamic range	dB	>60	
Max. SNR	dB	38.3	
Max. Gr/Gb ratio		<2%	
Max. frame rate	fps	15fps@full resolution 30fps@VGA	
Max. CRA	degree	23.4	+/- 1.5 (21.9 ~ 24.9)
ADC resolution	bit	10	

Note: For more information of sensor please refer to the S5K6AAFX and SN9C233AJG specification.

Mechanical Drawing

CP8171-D130BF-E Camera Module

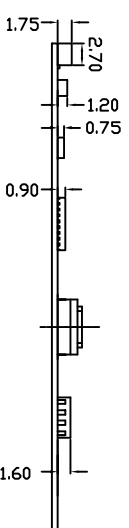
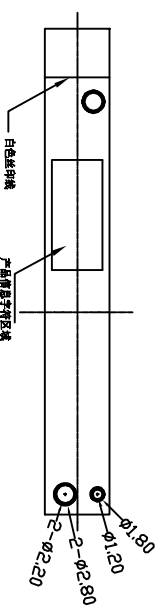
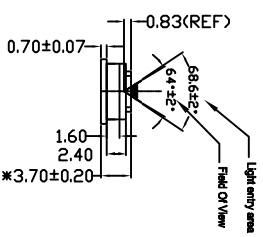
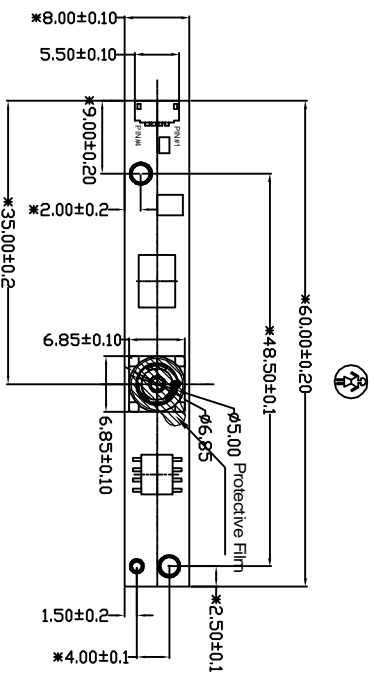

PIN DESCRIPTION

1	USB-POWER(+5V)
2	USB-DM(D-)
3	USB-DP(D+)
4	GND

主要参数 (Module Specification)	
焦距 (FFL)	2.28mm
光圈 (F/NO)	2.4±5%
视角 (View Angle)	64.2° ±2°
畸变 (Distortion)	< 1 %
解析力 (Image Quality)	≥ 400 TV line
景深 (Focusing Range)	40 cm ~ Infinity
感光芯片 (Chip Type)	SK6A6FX
像素 (Array Size)	1.3M
镜头类型 (Lens Size)	1/61MCH 3P+1R

Note: 1. * Critical Dimension
2. UNSPECIFIED TOLANCE ±0.1mm

CUSTOMER APPROVE		AMEND		光电感应模组	
Mechanical	Electrical			TOLERANCE DECIMAL	TRULY SEMICONDUCTORS LTD.
△	△			x ± .30	PRODUCT NO.
△	△			xx ± .20	CP8171-D130BF-E
△	△			± 1/4"	D/WN Francis 20090420
△	△				DSN Francis 20090420
△	△				CHKD Francis 20090420
△	△				APPD 刘铁楠 20090420
△	△				NDT IN SCALE UNIT mm SHEET: 1/1

Appearance Specification

NO.	Item	Standard	Importance Class
1	Top side of Lens	No obvious impurity and oil impurity on the front of lens within the half area; The defect(unfeeling) limitation: width \leq 1mm, length \leq 2mm, the defect number \leq 2; No feeling defect; The width of defects and gaps on the outside of Lens \leq 0.3mm. Others are unlimited.	A
2	Screw glue	Glue homogeneous distributing around lens circle side .Not allows to excess glue over the height of Lens and Holder outside.	A
3	L1 Plastic	No defect and dust check from 45° angle under the reflexing light and from 0° under the highlight	A
4	Holder	No obvious impurity and distortion of outline. The width and length of defect is unlimited, the depth \leq 0.1mm and \leq 1/4 of the thickness of Holder.	B
5	Sealed glue	Glue distributing between holder and FPC must be homogeneous and smooth. Not allows to excess glue over the width of holder.	A
6	FPC/PCB	Edge defect limitation: width \leq 1/2H(H is minimum.)、length \leq 1mm、 defect numbers per edge \leq 2(No tearing gap inby edge for FPC); Edge outshoot limitation (width \leq 0.3mm,length \leq 1mm); No obvious impurity on the surface, label and mark shall be recognizable and Clear	A
7	Double coated tapes	Adhered direction shall be right. Not allows to excess steel plate edge. No alveoli and stick. Not allows to peel glue and rip protective paper when tear the protective paper.	B
8	Protective film	No dust in the glue side. Not allows to float or drop. Adhered direction shall be right.	B

Remark:

1. The definition of the appearance importance class

A: The defect can be found in the finished product, or have obvious visual differences from good products, such as crack, defect and dust, or influence image quality, or are appointed by the customer. We will emphasize these items and check all products.

B: The defect can be found in the finished product and has visual difference from the good one, but will not affect customer's aesthetic judgement. Or the defect can not be found in the finished product and will not generate functional problem, but will slightly influence sequential manufacture process or condition. We will supervise these items in the manufacturing process and check products selectively.

2. Sampling standard

Referenced standard: GB/T 2828.1-2003/ISO 2859-1:1999 and ANSI/ASQC.4-1993 II

Image Specification

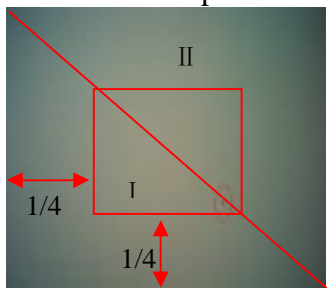
NO.	Item	Standard	Important Class
1	TV Line	Center \geq 500 8 point of 0.7 viewing field \geq 400	A
2	Shading	The lightness of 90% viewing area \geq 40% of center lightness(Lens correction Shading [Turn off]); The lightness of 90% viewing area \geq 60% of center lightness(Lens correction Shading [Turn on])	A
3	Dust	No dust in the center viewing area; Border area according to the limit samples	A
4	Dead pixel	No in the viewing area.	A
5	Wound pixel 	I area: Blemish number \leq 1 II area: Blemish number \leq 4	B
6	Color	Color distortion ratio of center \pm 15%	B
7	Gray Scale	Margin of two near scales' brightness \geq 6	B
8	Distortion	$<$ 1%	B
9	Flare	No flare in 45° viewing angle; No ghost in full viewing angle	B

QA Plan

NO.	Item	Sampling frequency	Measure	Remark
Image and reliability item				
1	TV Line	AQL 0.65 II Class	Same as production	100% Inspection
2	Shading	AQL 0.65 II Class	Same as production	100% Inspection
3	Dust	AQL 0.65 II Class	Same as production	100% Inspection
4	Dead pixel	AQL 0.65 II Class	Same as production	100% Inspection
5	Wound pixel	AQL 1.5 II Class	Same as production	100% Inspection
6	Color	AQL 1.5 II Class	Same as production	100% Inspection
7	Gray Scale	AQL 1.5 II Class	Same as production	100% Inspection
8	Distortion	N=5,c=0 per batch	Same as production	Sampling by QA
9	Flare	N=5,c=0 per batch	Same as production	Sampling by QA
Appearance Check Items				
1	Top side of Lens	AQL 1.0 II Class	Same as production	100% Inspection
2	Screw glue	AQL 1.0 II Class	Same as production	100% Inspection
3	L1 Plastic	AQL 1.0 II Class	Same as production	100% Inspection
4	Holder	AQL 1.5 II Class	Same as production	100% Inspection
5	Sealed glue	AQL 1.0 II Class	Same as production	100% Inspection
6	FPC/PCB	AQL 1.0 II Class	Same as production	100% Inspection
7	Double Coated Tapes	AQL 1.5 II Class	Same as production	100% Inspection
8	Protective Film	AQL 1.5 II Class	Same as production	100% Inspection

Sample:

Referenced standard: GB/T 2828.1-2003/ISO 2859-1:1999 and ANSI/ASQC.4-1993 II

PRECAUTIONS FOR USING CCM MODULES

Handling Precautions

- DO NOT try to open the unit enclosure as there is no user-serviceable component inside. To prevent damage to the camera module by electrostatic discharge, handling the camera module only after discharging all static electricity from yourself and ensuring a static-free environment for the camera module.
- DO NOT touch the top surface of the lens.
- DO NOT press down on the lens.
- DO NOT try to focus the lens.
- DO NOT put the camera module in a dusty environment.
- To reduce the risk of electrical shock and damage to the camera module, turn off the power before connect and disconnect the camera module.
- DO NOT drop the camera module more than 60 cm onto any hard surface.
- DO NOT expose camera module to rain or moisture.
- DO NOT expose camera module to direct sunlight.
- DO NOT put camera in a high temperature environment.
- DO NOT use liquid or aerosol cleaners to clean the lens.
- DO NOT make any charges or modifications to camera module.
- DO NOT subject camera module to strong electromagnetic field.
- DO NOT subject the camera module to excessive vibration or shock.
- DO NOT Impact or nip CCM module with spiculate things
- DO NOT alter, modify or change the shape of the tab on the metal frame.
- DO NOT make extra holes on the printed circuit board, modify its shape or change the positions of components to be attached.
- DO NOT damage or modify the pattern writing on the printed circuit board.
- Absolutely DO NOT modify the zebra rubber strip (conductive rubber) or heat seal connector
- Except for soldering the interface, DO NOT make any alterations or modifications with a soldering iron.
- DO NOT twist FPC of CCM.

Apply indication

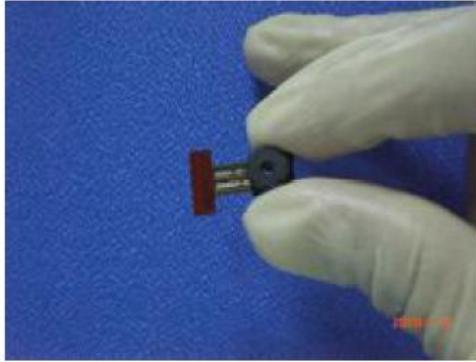

Correct

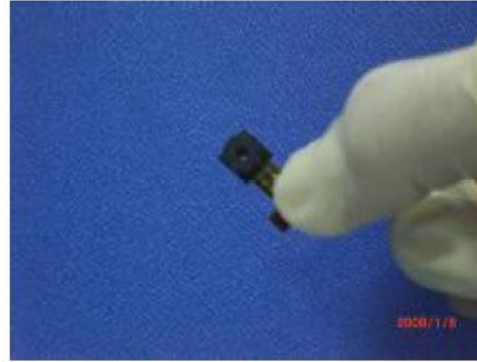

Incorrect

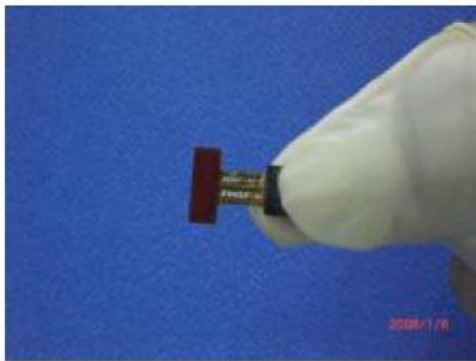

Incorrect

Precaution for soldering the CCM:

	Manual soldering	Machine drag soldering	Machine press soldering
No ROHS product	290°C ~350°C. Time: 3-5S.	330°C ~350°C. Speed: 4-8 mm/s.	300°C ~330°C. Time: 3-6S. Press: 0.8~1.2Mpa
ROHS product	340°C ~370°C. Time: 3-5S.	350°C ~370°C. Speed: 4-8 mm/s.	330°C ~360°C. Time: 3-6S. Press: 0.8~1.2Mpa

- (1) If soldering flux is used, be sure to remove any remaining flux after finishing to soldering operation. (This does not apply in the case of a non-halogen type of flux.) It is recommended that you protect the lens surface with a cover during soldering to prevent any damage due to flux spatters.
- (2) The CCM module and board should not be detached more than three times. This maximum number is determined by the temperature and time conditions mentioned above, though there may be some variance depending on the temperature of the soldering iron.

Other precautions

For correct using please refer to the relative criterions of electronic products.

Limited Warranty

Unless agreed between TRULY and customer, TRULY will replace or repair any of its CCM modules which are found to be functionally defective when inspected in accordance with TRULY CCM acceptance standards for a period of one year from date of shipments. Cosmetic/visual defects must be returned to TRULY within 90 days of shipment. Confirmation of such date shall be based on freight documents. The warranty liability of TRULY limited to repair and/or replacement on the terms set forth above. TRULY will not be responsible for any subsequent or consequential events.

Return CCM under warranty

No warranty can be granted if the precautions stated above have been disregarded. The typical examples of violations are:

- Holder is apart from module.
- Holder or Connector is anamorphic.
- Connector is turnup.
- FPC is lacerated or disconnection, and so on.

Module repairs will be invoiced to the customer upon mutual agreement. Modules must be returned with sufficient description of the failures or defects. Any connectors or cable installed by the customer must be removed completely without damaging the PCB eyelet, conductors and terminals.

Package Specification

Packaging Design

Product No.	CP8171-D130BF-E	Release date	
Product name	Compact Camera Module	Releaser	
Supplier	TRULY SEMI CONDUCTORS LTD	Recycle	()YES ()NO
Quantity/ each box	TBD	Material for box	() paper () plastic
Outer carton box size	TBD	Box type	()new ()update
Quantity / inner box * Quantity / outer box	TBD	Weight	g / pcs Kg / outer box BOX=TYPE Record of SRF Dept.

Packing Standards:

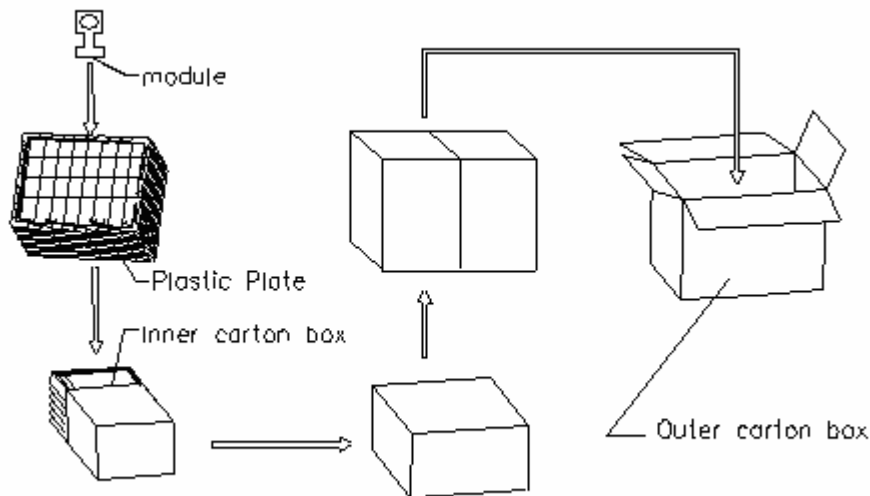

There are TBD modules each plastic plate.

There are TBD modules each inner carton box..

There are TBD inner carton boxes each outer carton box.

Requirements of outer carton box :

1. Weight(Max): TBD Kg
2. Height (Max): TBD M
3. Prohibition: Box made by log

Material for Plastic tray

It is made of antistatic polystyrene which has no chemical pollution. Surface resistivity : 10^6 ohm/sq

PRIOR CONSULT MATTER

- 1.①For Truly standard products, we keep the right to change material, process for improving the product property without notice on our customer.
②For OEM products, if any change needed which may affect the product property, we will consult with our customer in advance.
2. If you have special requirement about reliability condition, please let us know before you start the test on our samples.

FACTORY CONTACT INFORMATION

FACTORY NAME: TRULY SEMICONDUCTORS LTD.

FACTORY ADDRESS: Truly Industrial Area, ShanWei City, GuangDong, China

FACTORY PHONE: 86-0660-3380061 **FAX:** 86-0660-3371772