

**PRODUCT** : CAMERA MODULE  
**MODEL NO.** : CS2758-D030SF-E  
**SUPPLIER** : TRULY SEMICONDUCTORS LTD.  
**DATE** : April 14, 2008



CERT. No. 946535  
ISO9001  
TL9000

# SPECIFICATION

Revision:1.0

**CS2758-D030SF-E**

If there is no special request from customer, TRULY SEMICONDUCTORS Co., Ltd will not reserve the tooling of the product under the following conditions:  
1. There is no response from customer in two years after TRULY SEMICONDUCTORS Co., Ltd submit the samples;  
2. There is no order in two years after the latest mass production.  
And correlated data (include quality record) will be reserved one year more after tooling was discarded.

**TRULY SEMICONDUCTORS LTD:**      **CUSTOMER:**

Quality Assurance Department: \_\_\_\_\_  
Approved by:  
  
Technical Department: \_\_\_\_\_

Approved by:



# CONTENTS

- n KEY INFORMATION
- n PIN ASSIGNMENT
- n ELECTRICAL CHARACTERISTICS
- n MECHANICAL DRAWING
- n APPEARANCE SPECIFICATION
- n IMAGE SPECIFICATION
- n QA PLAN
- n PACKAGE SPECIFICATION
- n PRIOR CONSULT MATTER
- n FACTORY CONTACT INFORMATION

WRITTEN BY	CHECKED BY	APPROVED BY
HUANG WEI NA	YAN SI ZHI	LIU TIE NAN

**Key Information**

<b>Module No.</b>		<b>CS2758-D030SF-E</b>
Module Size		18.00mm x18.00mm x14.52mm
Image Quality		≥250 TV line
Sensor Type		OV7720
Array Size		640 X 480(VGA)
Power supply	Digital Core	1.8VDC+/-10%
	Analog	3.0V to3.3V
	I/o	1.7V to 3.3V
Lens		1/3.75 inch 2P+2G+IR
Focus(F.NO)		2.4
View Angle		93.9°
Image Area		3984μm x 2952μm
Object distance		TBD
Sensitivity		3.0V/(Lux-sec)
Pixel size		6.0μm x 6.0μm
IR Cutter		650+/-10nm
Temperature Range		-20° C to 70° C
Output Formats(8-bit)		.YUV/YCbCr 4:2:2 .RGB 565/555/444 .GRB 4:2:2 .Raw RGB Data
Max Image Transfer Rate		60 fps for VGA
S/N Rate		50dB
Dynamic Range		60dB
IC Package		28 pin CSP2
Substrate		FPC
Scan Mode		Progressive
Power requirement	Active	120mW typical (60fps VGA YUV)
	Standby	<20μA
Electronics Exposure		Up to 510:1(for selected fps)
Dark current		40mV/s
Package		Antistatic Plastic

## Pin Assignment

No.	Name	Pin type	Description
1	NC		
2	AGND	Power	Analog Ground
3	SIO_D	I/O	SCCB serial interface data I/O
4	AVDD	Power	Analog power supply
5	SIO_C	Input	SCCB serial interface clock input
6	RESET	Input	System reset input,active low
7	VSYNC	Output	Vertical sync output
8	PWDN	Input (0)	Power Down Mode Selection 0: Normal mode 1: Power down mode
9	HREF	Output	HREF output
10	NC		
11	DOVDD	Power	Digital power supply for I/O
12	Y9	Output	Data output bit[9]
13	XCLK	Input	System clock input
14	Y8	Output	Data output bit [8]
15	DGND	Power	Digital Ground
16	Y7	Output	Data output bit [7]
17	PCLK	Output	Pixel clock output
18	Y6	Output	Data output bit [6]
19	Y2	Output	Data output bit [2]
20	Y5	Output	Data output bit [5]
21	Y3	Output	Data output bit [3]
22	Y4	Output	Data output bit [4]
23	Y1	Output	Data output bit [1]
24	Y0	Output	Data output bit [0]

## Electrical Characteristics

### 1. Absolute Maximum Ratings

Ambient Storage Temperature		-40°C to +95°C
Supply Voltages (with respect to Ground)	V <sub>DD-A</sub>	4.5 V
	V <sub>DD-C</sub>	3 V
	V <sub>DD-IO</sub>	4.5 V
All Input/Output Voltages (with respect to Ground)		-0.3V to V <sub>DD-IO</sub> +0.5V
Lead-free Temperature, Surface-mount process		245°C

NOTE: Exceeding the Absolute Maximum ratings shown above invalidates all AC and DC electrical specifications and may result in permanent device damage.

### 2. DC Characteristics (-20°C < Ta < 70°C)

Symbol	Parameter	Condition	Min	Typ	Max	Unit
V <sub>DD-A</sub>	DC supply voltage – analog	–	3.0	3.3	3.6	V
V <sub>DD-C</sub>	DC supply voltage – digital core	–	1.62	1.8	1.98	V
V <sub>DD-IO</sub>	DC supply voltage – I/O	–	2.5	–	3.3	V
I <sub>DDA</sub>	Active (operating) current	See Note <sup>a</sup>		10 + 8 <sup>b</sup>		mA
I <sub>DDS-SCCB</sub>	Standby current	See Note <sup>c</sup>		1		mA
I <sub>DDS-PWDN</sub>	Standby current			10	20	μA
V <sub>IH</sub>	Input voltage HIGH	CMOS	0.7 x V <sub>DD-IO</sub>			V
V <sub>IL</sub>	Input voltage LOW				0.3 x V <sub>DD-IO</sub>	V
V <sub>OH</sub>	Output voltage HIGH	CMOS	0.9 x V <sub>DD-IO</sub>			V
V <sub>OL</sub>	Output voltage LOW				0.1 x V <sub>DD-IO</sub>	V
I <sub>OH</sub>	Output current HIGH	See Note <sup>d</sup>	8			mA
I <sub>OL</sub>	Output current LOW		15			mA
I <sub>L</sub>	Input/Output leakage	GND to V <sub>DD-IO</sub>			± 1	μA

a. At 25°C, V<sub>DD-A</sub> = 3.3V, V<sub>DD-C</sub> = 1.8V, V<sub>DD-IO</sub> = 3.3V

I<sub>DDA</sub> = Σ(I<sub>DD-IO</sub> + I<sub>DD-C</sub> + I<sub>DD-A</sub>); f<sub>CLK</sub> = 24MHz at 30 fps YUV output, no I/O loading

b. I<sub>DD-C</sub> = 10mA, I<sub>DD-A</sub> = 8mA, without loading

c. At 25°C, V<sub>DD-A</sub> = 3.3V, V<sub>DD-C</sub> = 1.8V, V<sub>DD-IO</sub> = 3.3V

I<sub>DDS-SCCB</sub> refers to a SCCB-initiated Standby, while I<sub>DDS-PWDN</sub> refers to a PWDN pin-initiated Standby

d. Standard Output Loading = 25pF, 1.2KΩ

### 3. Functional and AC Characteristics (-20°C < Ta < 70°C)

Symbol	Parameter	Min	Typ	Max	Unit
<b>Functional Characteristics</b>					
	A/D Differential non-linearity		$\pm 1/2$		LSB
	A/D Integral non-linearity		$\pm 1$		LSB
	AGC Range			30	dB
	Red/Blue adjustment range			12	dB
<b>Inputs (PWDN, CLK, RESET#)</b>					
f <sub>CLK</sub>	Input clock frequency	10	24	48	MHz
t <sub>CLK</sub>	Input clock period	21	42	100	ns
t <sub>CLK:DC</sub>	Clock duty cycle	45	50	55	%
t <sub>S:RESET</sub>	Setting time after software/hardware reset			1	ms
t <sub>S:REG</sub>	Settling time for register change (10 frames required)			300	ms
<b>SCCB Timing (see Figure 4)</b>					
f <sub>SCL</sub>	Clock frequency			400	KHz
t <sub>LOW</sub>	Clock low period	1.3			μs
t <sub>HIGH</sub>	Clock high period	600			ns
t <sub>AA</sub>	SCL low to data out valid	100		900	ns
t <sub>BUF</sub>	Bus free time before new START	1.3			μs
t <sub>HD:STA</sub>	START condition hold time	600			ns
t <sub>SU:STA</sub>	START condition setup time	600			ns
t <sub>HD:DAT</sub>	Data in hold time	0			μs
t <sub>SU:DAT</sub>	Data in setup time	100			ns
t <sub>SU:STO</sub>	STOP condition setup time	600			ns
t <sub>R</sub> , t <sub>F</sub>	SCCB rise/fall times			300	ns
t <sub>OH</sub>	Data out hold time	50			ns
<b>Outputs (VSYNC, HREF, PCLK, and D[9:0] (see Figure 5, Figure 6, Figure 7, and Figure 8)</b>					
t <sub>PDV</sub>	PCLK[↓] to data out Valid			5	ns
t <sub>SU</sub>	D[9:0] setup time	15			ns
t <sub>HD</sub>	D[9:0] Hold time	8			ns
t <sub>PHH</sub>	PCLK[↓] to HREF[↑]	0		5	ns
t <sub>PHL</sub>	PCLK[↓] to HREF[↓]	0		5	ns
AC Conditions:	<ul style="list-style-type: none"> <li>• V<sub>DD</sub>: V<sub>DD-C</sub> = 1.8V, V<sub>DD-A</sub> = 3.3V, V<sub>DD-IO</sub> = 3.3V</li> <li>• Rise/Fall Times: I/O: 5ns, Maximum SCCB: 300ns, Maximum</li> <li>• Input Capacitance: 10pf</li> <li>• Output Loading: 25pF, 1.2KΩ to 3.3V</li> <li>• f<sub>CLK</sub>: 24MHz</li> </ul>				

**Note:** For more information of sensor please refer to the OV7720 specification.



### Appearance Specification

NO.	Item	Standard	Importance Class
1	Top side of Lens	No obvious impurity and oil impurity on the front of lens within the half area; The defect(unfeeling) limitation: width $\leq$ 1mm, length $\leq$ 2mm, the defect number $\leq$ 2; No feeling defect; The width of defects and gaps on the outside of Lens $\leq$ 0.3mm. Others are unlimited.	A
2	Screw glue	Normally screw glue shall be symmetrical distributed around lens circle side. Particular circs, glue distribution must not disturb customer's assembly operation.	A
3	L1 Glass	No defect and dust check from 45° angle under the reflexing light and from 0° under the highlight	A
4	Holder	No obvious impurity and distortion of outline. The width and length of defect is unlimited, the depth $\leq$ 0.1mm and $\leq$ 1/4 of the thickness of Holder.	B
5	Sealed glue	Sealed glue distributing between holder and FPC must be symmetrical and smooth. Not allow glue leakage and asymmetric thickness. After holder assembly, the thickness distance between one side and its opposite side shall be less than 0.2mm. Excess glue over the holder shall not make the outside dimension be out of control.	A
6	FPC/PCB	Edge defect limitation: width $\leq$ 1/2H (H is minimum.)、 length $\leq$ 1mm、 defect numbers per edge $\leq$ 2(No tearing gap inby edge for FPC); Edge outshoot limitation (width $\leq$ 0.3mm, length $\leq$ 1mm). No obvious impurity and crease on the surface. If there was shield film on the surface, the spot size of the film shall be less than 0.3mm $\times$ 1mm and no line is exposed. If it was not be cleaned and did not influence the total thickness, it would be permitted. Label and mark shall be clear enough to be discerned.	A
7	Connector	No dust, fingerprint, and not allows to turning colors, distortion; Solder must be well; No open circuit or short circuit	A

8	Gold finger	No dust, fingerprint, and not allows to turning colors, burned, unsmoothed and peeled; No open circuit or short circuit; The defect width shall be smaller than 20% of gold finger's width. No copper/nickel exposed in defect. Numbers of defected pin shall be less than 3. The defect limitation:width $\leq$ 0.08mm,length $\leq$ 5mm.	A
9	Stiffener	Holder anchor pole length overtopping the steel plate shall be less than 0.2mm. No dust, rust and deep scratch on the steel surface without Double coated tapes.	B
10	Double coated tapes	Adhered direction shall be right. Not allows to excess steel plate edge. No alveoli and stick. Not allows to peel glue and rip protective paper when tear the protective paper.	B
11	Protective film	No dust in the glue side. Not allows to float or drop. Adhered direction shall be right.	B

Remark:

1. The definition of the appearance importance class

- A: The defect can be found in the finished product, or have obvious visual differences from good products, such as crack, defect and dust, or influence image quality, or are appointed by the customer. We will emphasize these items and check all products.
- B: The defect can be found in the finished product and has visual difference from the good one, but will not affect customer's aesthetic judgement. Or the defect can not be found in the finished product and will not generate functional problem, but will slightly influence sequential manufacture process or condition. We will supervise these items in the manufacturing process and check products selectively.

2. Sampling standard

Referenced standard: GB/T 2828.1-2003/ISO 2859-1:1999 and ANSI/ASQC.4-1993 II

### Image Specification

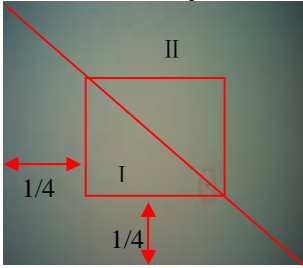
NO.	Item	Standard	Important Class
1	TV Line	Center $\geq$ 350 8 point of 0.7 viewing field $\geq$ 250	A
2	Shading	The lightness of 90% viewing area $\geq$ 40% of center lightness(Lens correction Shading [Turn off]); The lightness of 90% viewing area $\geq$ 60% of center lightness(Lens correction Shading [Turn on])	A
3	Dust	No dust in the center viewing area; Border area according to the limit samples	A
4	Dead pixel	No in the viewing area.	A
5	Wound pixel 	I area: Blemish number $\leq$ 2 II area: Blemish number $\leq$ 6	B
6	Color	Color distortion ratio of center $\pm$ 15%	B
7	Gray Scale	Margin of two near scales' brightness $\geq$ 6	B
8	Distortion	$<$ 7.5%	B
9	Flare	No flare in 45° viewing angle; No ghost in full viewing angle	B

**QA Plan**

NO.	Item	Sampling frequency	Measure	Remark
Image and reliability item				
1	TV Line	AQL 0.65 II Class	Same as production	100% Inspection
2	Shading	AQL 0.65 II Class	Same as production	100% Inspection
3	Dust	AQL 0.65 II Class	Same as production	100% Inspection
4	Dead pixel	AQL 0.65 II Class	Same as production	100% Inspection
5	Wound pixel	AQL 1.5 II Class	Same as production	100% Inspection
6	Color	AQL 1.5 II Class	Same as production	100% Inspection
7	Gray Scale	AQL 1.5 II Class	Same as production	100% Inspection
8	Distortion	N=5,c=0 per batch	Same as production	Sampling by QA
9	Flare	N=5,c=0 per batch	Same as production	Sampling by QA
Appearance Check Items				
1	Top side of Lens	AQL 1.0 II Class	Same as production	100% Inspection
2	Screw glue	AQL 1.0 II Class	Same as production	100% Inspection
3	L1 Glass	AQL 1.0 II Class	Same as production	100% Inspection
4	Holder	AQL 1.5 II Class	Same as production	100% Inspection
5	Sealed glue	AQL 1.0 II Class	Same as production	100% Inspection
6	FPC/PCB	AQL 1.0 II Class	Same as production	100% Inspection
7	Connector	AQL 1.0 II Class	Same as production	100% Inspection
8	Gold finger	AQL 1.0 II Class	Same as production	100% Inspection
9	Stiffener	AQL 1.5 II Class	Same as production	100% Inspection
10	Double coated tapes	AQL 1.5 II Class	Same as production	100% Inspection
11	Protective film	AQL 1.5 II Class	Same as production	100% Inspection

Sample:

Referenced standard: GB/T 2828.1-2003/ISO 2859-1:1999 and ANSI/ASQC.4-1993 II

## Package Specification

### Packaging Design One

Product No.	CS2758-D030SF-E	Release date							
Product name	Compact Camera Module	Releaser							
Supplier	TRULY SEMI CONDUCTORS LTD	Recycle	<input type="checkbox"/> YES <input checked="" type="checkbox"/> NO						
Quantity/ each box	TBD	Material for box	<input checked="" type="checkbox"/> paper <input type="checkbox"/> plastic						
Outer carton box size	405mm*290mm*290mm	Box type	<input checked="" type="checkbox"/> new <input type="checkbox"/> update						
Quantity / inner box * Quantity / outer box	TBD	Weight	<table border="1"> <tr> <td>g / pcs</td> <td>BOX=TYPE</td> <td>TBD</td> </tr> <tr> <td>Kg / outer box</td> <td>Record of SRF Dept.</td> <td>Kg(Max)</td> </tr> </table>	g / pcs	BOX=TYPE	TBD	Kg / outer box	Record of SRF Dept.	Kg(Max)
g / pcs	BOX=TYPE	TBD							
Kg / outer box	Record of SRF Dept.	Kg(Max)							

#### Packing Standards:

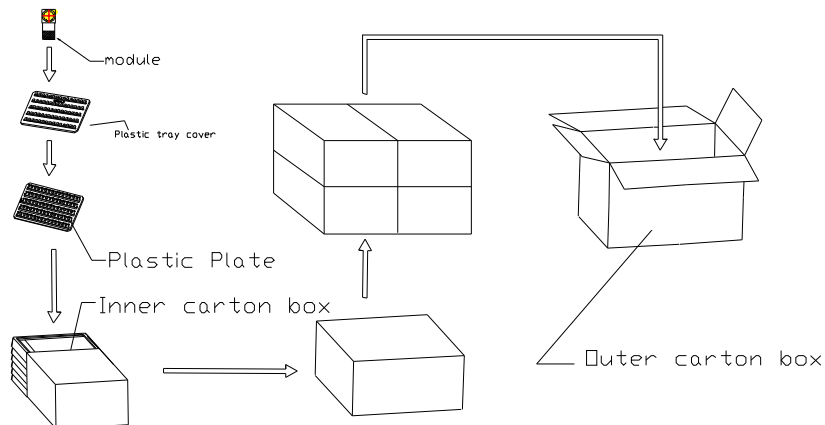

There are TBD modules each plastic plate.

There are TBD modules each inner carton box..

There are 4 each outer carton box.

#### Requirements of outer carton box :

1. Weight(Max): TBD Kg
2. Height (Max): 0.29 M
3. Prohibition: Box made by log

#### Material for Plastic tray

It is made of antistatic polystyrene which has no chemical pollution. Surface resistivity :  $10^6$  ohm/sq

## Packaging Design Two

Product No.	CS2758-D030SF-E	Release date					
Product name	Compact Camera Module	Releaser					
Supplier	TRULY SEMI CONDUCTORS LTD	Recycle	<input type="checkbox"/> YES <input checked="" type="checkbox"/> NO				
Quantity/ each box	TBD	Material for box	<input checked="" type="checkbox"/> paper <input type="checkbox"/> plastic				
Outer carton box size	405 mm *290 mm *170 mm	Box type	<input checked="" type="checkbox"/> new <input type="checkbox"/> update				
Quantity / inner box * Quantity / outer box	TBD	Weig ht	<table border="1"> <tr> <td>g / pcs</td> <td rowspan="2">BOX-TYPE Record of SRF Dept.</td> <td rowspan="2">TBD Kg(Max)</td> </tr> <tr> <td>Kg / outer box</td> </tr> </table>	g / pcs	BOX-TYPE Record of SRF Dept.	TBD Kg(Max)	Kg / outer box
g / pcs	BOX-TYPE Record of SRF Dept.	TBD Kg(Max)					
Kg / outer box							

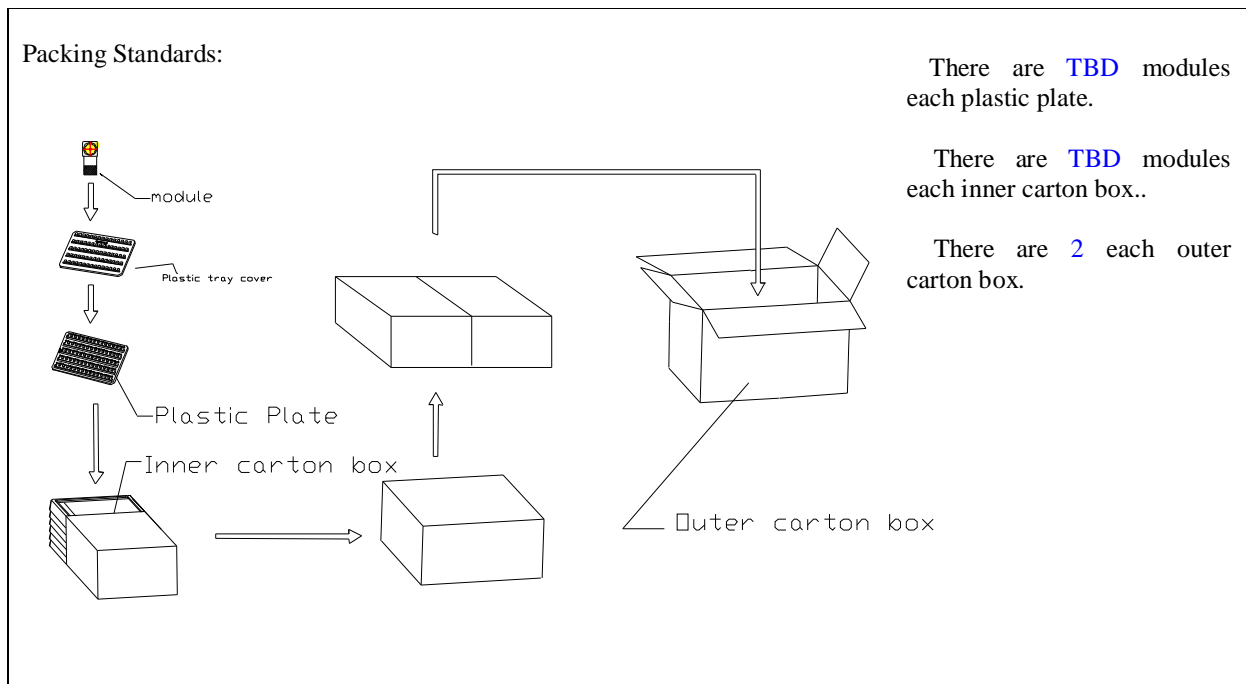

### Requirements of outer carton box :

4. Weight(Max): TBD Kg
5. Height (Max): 0.17 M
6. Prohibition: Box made by log

### Material for Plastic tray

It is made of antistatic polystyrene which has no chemical pollution. Surface resistivity :  $10^6$  ohm/sq

**PRIOR CONSULT MATTER**

- 1.①For Truly standard products, we keep the right to change material, process for improving the product property without notice on our customer.  
②For OEM products, if any change needed which may affect the product property, we will consult with our customer in advance.
2. If you have special requirement about reliability condition, please let us know before you start the test on our samples.

**FACTORY CONTACT INFORMATION**

**FACTORY NAME:** TRULY SEMICONDUCTORS LTD.

**FACTORY ADDRESS:** Truly Industrial Area, ShanWei City, GuangDong, China

**FACTORY PHONE:** 86-0660-3380061    **FAX:** 86-0660-3371772