

PRODUCT : LCD MODULE**MODEL NO.** : MFT-G320240DPSW-100W-E**SUPPLIER** : TRULY SEMICONDUCTORS LTD.**DATE** : Jan.23.2006CERT. No. 946535
(ISO9001)CERT. No. H002005
(ISO14001)

SPECIFICATION

Revision: 1.1

MFT-G320240DPSW-100W-E

This specification maybe changed without any notice in order to improve performance or quality etc. Please contact TRULY R&D department for update specification and product status before design for this product or release the order.

TRULY SEMICONDUCTORS LTD:**CUSTOMER:**

Quality Assurance Department: _____
Approved by:
Technical Department: _____

Approved by:

CONTENTS

- n GENERAL INFORMATION
- n EXTERNAL DIMENSIONS
- n ABSOLUTE MAXIMUM RATINGS
- n ELECTRICAL CHARACTERISTICS
- n TIMING OF POWER SUPPLY
- n BACKLIGHT CHARACTERISTICS
- n ELECTRO-OPTICAL CHARACTERISTICS
- n INTERFACE DESCRIPTION
- n PART LIST
- n APPLICATION CIRCUIT
- n INITIAL CODE
- n ROHS STANDARD
- n RELIABILITY TEST
- n QUALITY GUARANTEE
- n INSPECTION CRITERION
- n PRECAUTIONS FOR USING LCD MODULES
- n PRIOR CONSULT MATTER
- n FACTORY CONTACT INFORMATION

WRITTEN BY	CHECKED BY	APPROVED BY
XT LIU	X.C XIE	K.K.HO

n GENERAL INFORMATION

Item	Contents	Unit
LCD type	FSTN	/
Viewing direction	6:00	O' Clock
Glass area (W × H)	96.8 × 70.7	mm ²
Viewing area (W×H)	77.79 × 58.59	mm ²
Number of Dots	320 × 240	/
Dot size (W × H)	0.23 × 0.23	mm ²
Dot pitch (W × H)	0.24 × 0.24	mm ²
Backlight Type	LED	/
Input voltage	3.0	V

n EXTERNAL DIMENSIONS

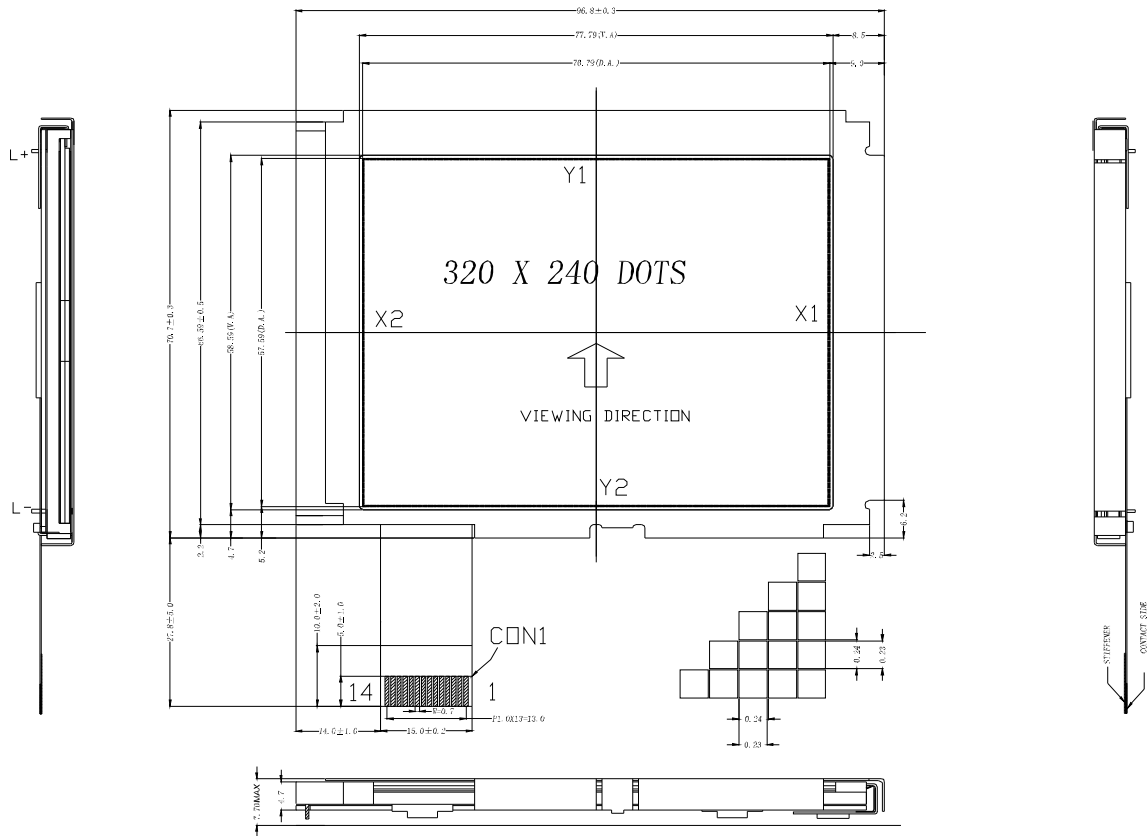

BLOCK DIAGRAM

CON1

1	2	3	4	5	6	7	8	9	10	11	12	13	14
VDD	VSS	VEE	FLM	NC	CL1	CL2	D0	D1	D2	D3	DISPLAYOFF	LED+	LED-

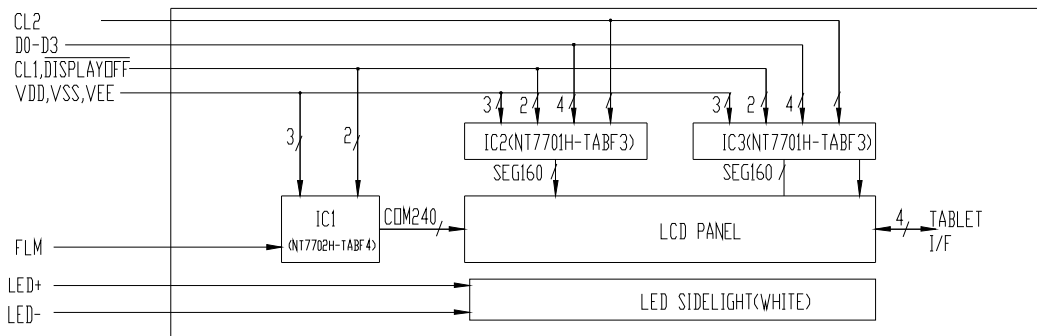

NOTES:

- Operating Temperature -20 °C TO 70 °C
Storage Temperature -30 °C TO 80 °C
- Polarizer Type: R □ F ■ T □
- Metal frame nose solder to PCB
- LED: 100CD/M2(MIN)

nABSOLUTE MAXIMUM RATINGS

Parameter	Symbol	Min	Max	Unit
Supply voltage for logic	V _{DD}	-0.3	7.0	V
Driver supply voltage	V _{EE}	0	25	V
Input voltage	V _{IN}	-0.3	V _{DD} +0.3	V
Operating temperature	T _{OP}	-20	70	°C
Storage temperature	T _{ST}	-30	80	°C
Humidity	RH		90% (Max60°C)	RH

nELECTRICAL CHARACTERISTICS

DC CHARACTERISTICS

Parameter	Symbol	Condition	Min	Typ	Max	Unit
Supply voltage for logic	V _{DD} -V _{SS}		2.7	5.0	5.5	V
Input Current	I _{dd}	V _{DD} =5.0V	---	---	0.5	mA
Operating voltage for LCD	V _{LCD} =V _{EE} - V _{SS}	25°C	21	21.5	23	V
Input voltage 'H' level	V _{IH}	---	0.8V _{DD}	---	V _{DD}	V
Input voltage 'L' level	V _{IL}	---	0	---	0.9	V
Output voltage 'H' level	V _{OH}	---	0.8V _{DD}	---	V _{DD}	V
Output voltage 'L' level	V _{OL}	---	0	---	0.2V _{DD}	V

n TIMING OF POWER SUPPLY

◇ AC Characteristics (NT7701)

Parameter	Symbol	Min.	Typ.	Max.	Unit	Condition
Shift clock period	twck	71	-		ns	tr, tf ≤ 10ns, Note 1
Shift clock "H" pulse width	twckH	23	-		ns	
Shift clock "L" pulse width	twckL	23	-		ns	
Data setup time	tds	10	-		ns	
Data hold time	tDH	20	-		ns	
Latch pulse "H" pulse width	twLPH	23	-		ns	
Shift clock rise to Latch pulse rise time	tLD	0	-		ns	
Shift clock fall to Latch pulse fall time	tSL	25	-		ns	
Latch pulse rise to Shift clock rise time	tLS	25	-		ns	
Latch pulse fall to Shift clock rise time	tLH	25	-		ns	
Input signal rise time	tr		-	50	ns	Note 2
Input signal fall time	tr		-	50	ns	Note 2
Enable setup time	ts	21	-		ns	
$\overline{\text{DISPOFF}}$ Removal time	tSD	100	-		ns	
$\overline{\text{DISPOFF}}$ enable pulse width	twDL	1.2	-		μs	
Output delay time (1)	td		-	40	ns	CL = 15pF
Output delay time (2)	tpd1, tpd2		-	1.2	μs	CL = 15pF
Output delay time (3)	tpd3		-	1.2	μs	CL = 15pF

Note

1. Take the cascade connection into consideration.
2. $(T_{ck} - twckH - twckL)/2$ is the maximum in the case of high speed operation.

(NT7701)

Parameter	Symbol	Min.	Typ.	Max.	Unit	Condition
Shift clock period	twck	125	-		ns	tr, tf ≤ 11ns, Note 1
Shift clock "H" pulse width	twckH	51	-		ns	
Shift clock "L" pulse width	twckL	51	-		ns	
Data setup time	tds	30	-		ns	
Data hold time	tdH	40	-		ns	
Latch pulse "H" pulse width	twLPH	51	-		ns	
Shift clock rise to Latch pulse rise time	tLD	0	-		ns	
Shift clock fall to Latch pulse fall time	tSL	51	-		ns	
Latch pulse rise to Shift clock rise time	tLS	51	-		ns	
Latch pulse fall to Shift clock fall time	tLH	51	-		ns	
Input signal rise time	tr		-	50	ns	Note 2
Input signal fall time	tr		-	50	ns	Note 2
Enable setup time	ts	36	-		ns	
$\overline{\text{DISPOFF}}$ Removal time	tSD	100	-		ns	
$\overline{\text{DISPOFF}}$ enable pulse width	twDL	1.2	-		μs	
Output delay time (1)	td		-	78	ns	CL = 15pF
Output delay time (2)	t _{pd1} , t _{pd2}		-	1.2	μs	CL = 15pF
Output delay time (3)	t _{pd3}		-	1.2	μs	CL = 15pF

Note

1. Take the cascade connection into consideration.
2. (tck - twckH - twckL)/2 is the maximum in the case of high speed operation.

(NT7702)

 Common Mode ($V_{SS} = V_S = 0V$, $V_{DD} = 2.5 - 5.5V$, $V_0 = 15$ to $30V$ and $T_A = -30$ to $+85^\circ C$, unless otherwise noted)

Parameter	Symbol	Min.	Typ.	Max.	Unit	Condition
Shift clock period	t_{WLP}	250	-	-	ns	$t_r, t_f \leq 20ns$
Shift clock "H" pulse width	t_{WLPH}	15	-	-	ns	$V_{DD} = +5.0V \pm 10\%$
		30	-	-	ns	$V_{DD} = +2.5 - +4.5V$
Data setup time	t_{SU}	30	-	-	ns	
Data hole time	t_H	50	-	-	ns	
Input signal rise time	t_r		-	50	ns	
Input signal fall time	t_f		-	50	ns	
$\overline{DISPOFF}$ Removal time	t_{SD}	100	-	-	ns	
$\overline{DISPOFF}$ enable pulse width	t_{WDL}	1.2	-	-	μs	
Output delay time (1)	t_{DL}	-	-	200	ns	$C_L = 15pF$
Output delay time (2)	t_{pd1}, t_{pd2}	-	-	1.2	μs	$C_L = 15pF$
Output delay time (3)	t_{pd3}	-	-	1.2	μs	$C_L = 15pF$

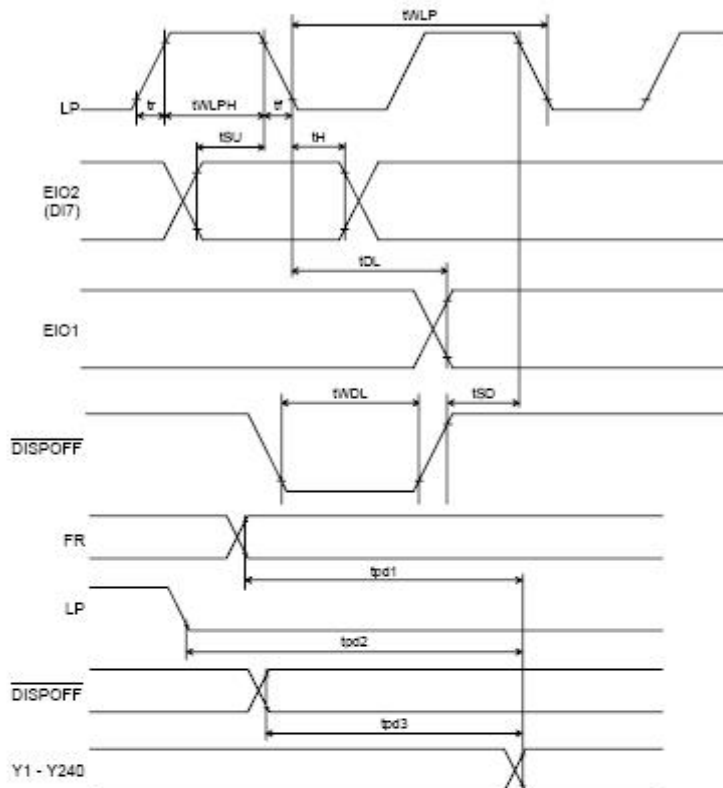
(NT7702)
Timing Characteristics of Common Mode

n BACKLIGHT CHARACTERISTICS

◇ ABSOLUTE MAXIMUM RATINGS

Item	Symbol	Condition	Rating	Unit
Absolute Maximum forward current	Ifm		125	mA
Peak forward current	Ifp	1 msec Plus 10% Duty Cycle	420	mA
Reverse Voltage	Vr		1.0	V
Power dissipation	Pd		250	mW
Operating Temperature Range	Topr		-20~+70	°C
Storage Temperature Range	Tstg		-30~+80	°C

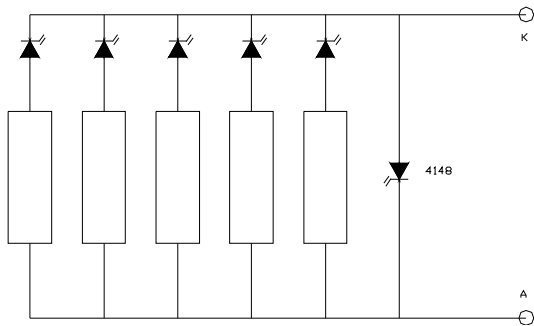

*LED CIRCUIT DIAGAM (LED 1x5=5 dies)

◇ ELECTRICAL—OPTICAL CHARACTERISTICS

(Ta=25°C)

Item	Symbol	Min	Typ	Max	Unit	Condition
Forward Current	If	65	75	85	mA	Vf=5V
Reverse Current	Ir		35		mA	Vr=0.8V
Luminance	Lv	200	250		cd/m ²	Vf=5V

nELECTRO-OPTICAL CHARACTERISTICS

Item	Symbol	Condition	Min	Typ	Max	Unit	Remark	Note
Response time	Tr	$\theta=0^\circ$ $\varnothing=0^\circ$ $T_a=25^\circ\text{C}$	---	230.5	---	ms	FIG.3	4
	Tf		---	232.7	---	ms	FIG.3	4
Contrast ratio	Cr		---	3.3	---	---	FIG 4.	1
Luminance uniformity	δ WHITE		---	---	---	%	FIG 4.	3
Surface Luminance	Lv		---	88.385	---	cd/m ²	FIG 4.	2
Viewing angle range	θ	$\varnothing = 90^\circ$	---	30	---	deg	FIG 5	5
		$\varnothing = 270^\circ$	---	30	---	deg		
		$\varnothing = 0^\circ$	---	32	---	deg		
		$\varnothing = 180^\circ$	---	20	---	deg		

Note 1. Contrast Ratio(CR) is defined mathematically as For more information see FIG 4.:

$$\text{Contrast Ratio} = \frac{\text{Average Surface Luminance with all white pixels } (P_1, P_2, P_3, P_4, P_5)}{\text{Average Surface Luminance with all black pixels } (P_1, P_2, P_3, P_4, P_5)}$$

Note 2. Surface luminance is the center point across the LCD surface 500mm from the surface with all pixels displaying white. For more information see FIG 4.

$$L_v = \text{Average Surface Luminance with all white pixels } (P_1, P_2, P_3, P_4, P_5)$$

Note 3. The uniformity in surface luminance, δ WHITE is determined by measuring luminance at each test position 1 through 5, and then dividing the maximum luminance of 5 points luminance by minimum luminance of 5 points luminance. For more information see FIG 4.

$$\delta \text{ WHITE} = \frac{\text{Minimum Surface Luminance with all white pixels } (P_1, P_2, P_3, P_4, P_5)}{\text{Maximum Surface Luminance with all white pixels } (P_1, P_2, P_3, P_4, P_5)}$$

Note 4. Response time is the time required for the display to transition from White to black(Rise Time, Tr) and from black to white(Decay Time, Tf). For additional information see FIG 3.

Note 5. Viewing angle is the angle at which the contrast ratio is greater than 2. The angles are determined for the horizontal or x axis and the vertical or y axis with respect to the z axis which is normal to the LCD surface. For more information see FIG 5.

FIG. 1 Optical Characteristic Measurement Equipment and Method

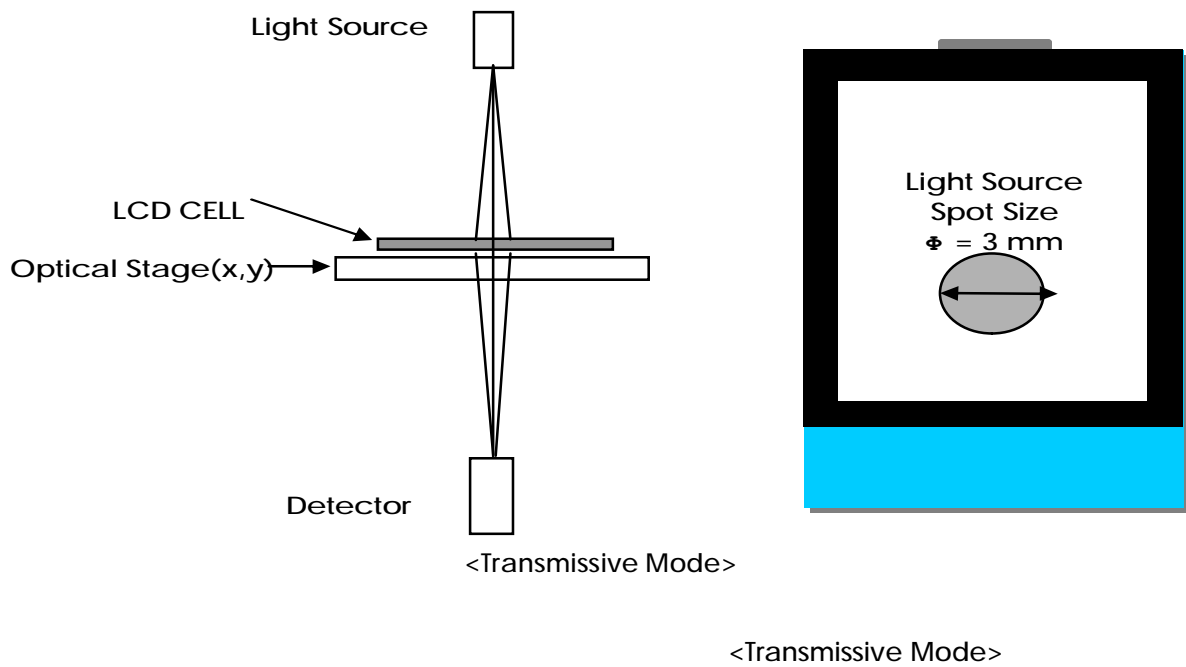

FIG. 2 Measuring method for optical characteristics in Reflective mode

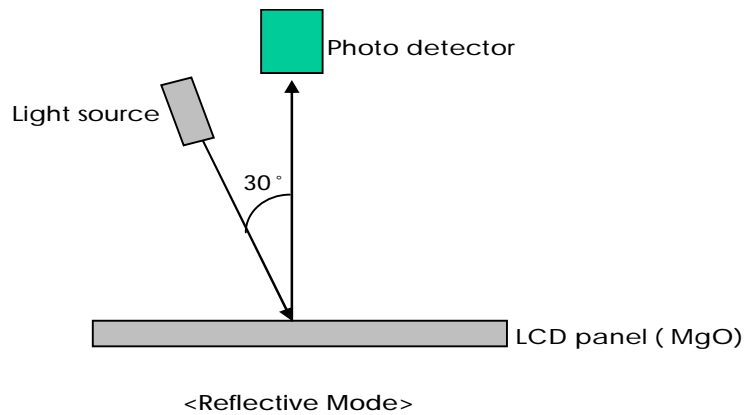
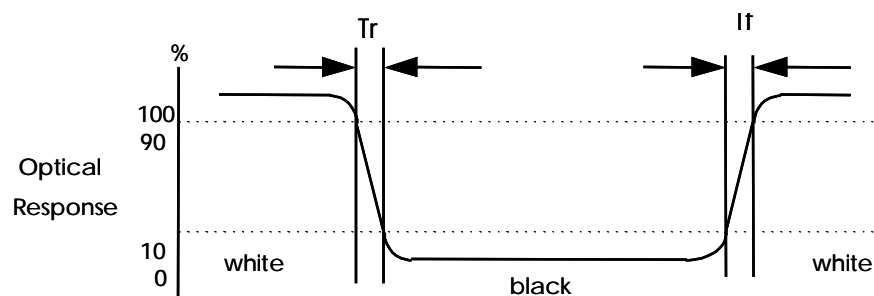

FIG. 3 The definition of Response Time

The response time is defined as the following figure and shall be measured by switching the input signal for “black” and “white”.



The values specified are at an approximate distance 500 mm from the LCD surface at a viewing angle of Φ and θ equal to 0° . Measurement condition : Refer to next pages (B - light source , Halogen Lamp, with polarizer)

FIG. 4 Measuring method for Contrast ratio, surface luminance, **Luminance** uniformity , CIE (x, y) chromaticity

<measuring point for luminance variation>

<measuring point for surface luminance>

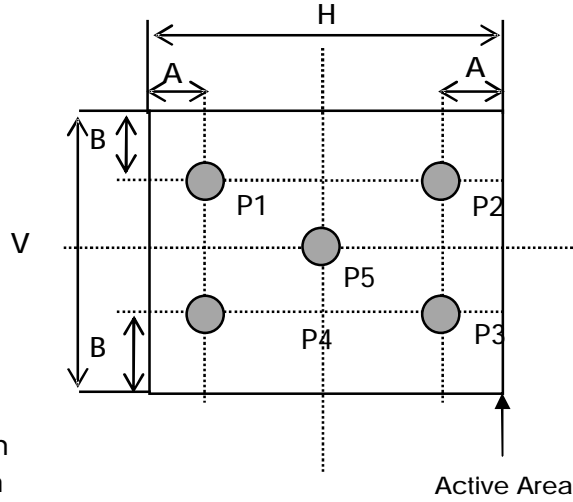

A : 5 mm

B : 5 mm

Light source spot size $\varnothing=2\text{mm}$

H,V : Active Area

measurement device is TOPCON luminance meter BM-7

FIG. 5 The definition of viewing angle

<dimension of viewing angle range>

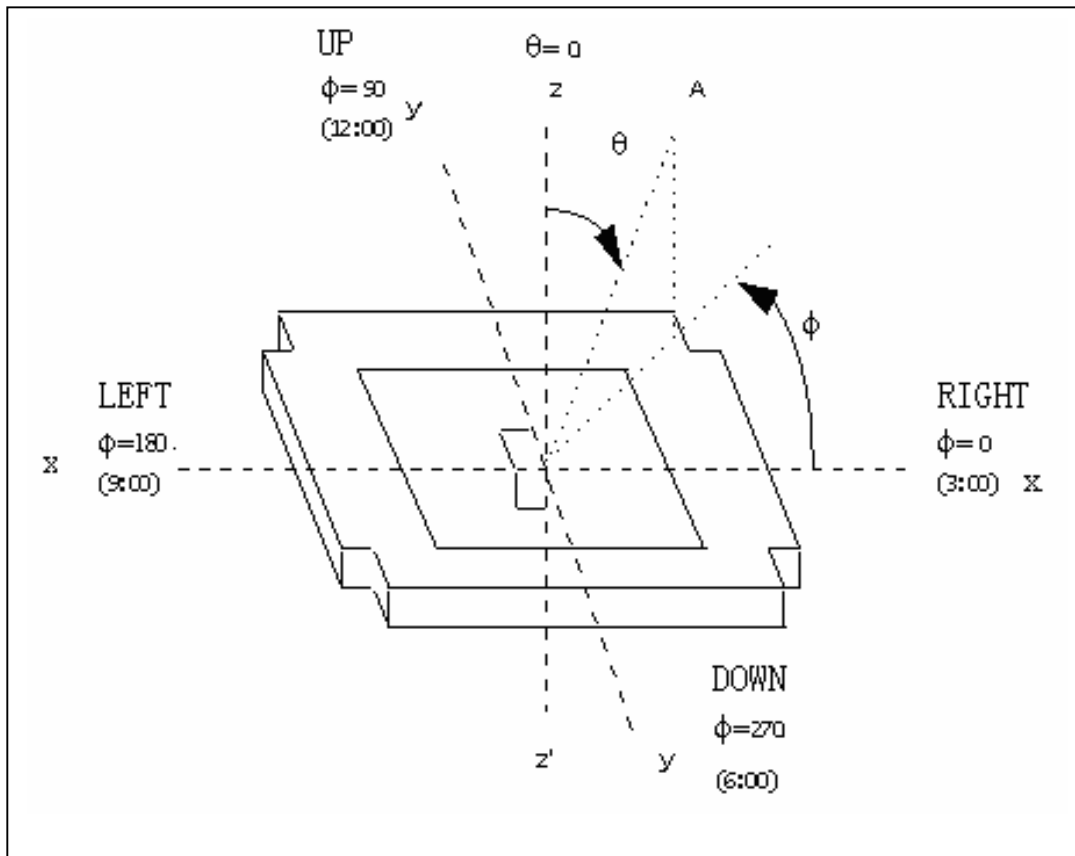

n INTERFACE DESCRIPTION

Pin No.	Symbol	Level	Description
1	VDD	5.0V	Logic system power supply pin
2	VSS	0V	Ground
3	VEE	21.5V	
4	FLM	H/L	Frame signal pin
5	NC	---	No connected
6	CL1	H/L	Latch pulse input pin for display data
7	CL2	H/L	Clock input pin for taking display data
8	D0	H/L	Data bit 0
9	D1	H/L	Data bit 1
10	D2	H/L	Data bit 2
11	D3	H/L	Data bit 3
12	/DISPALYOFF	H/L	Control input pin for output deselect level
13	LED+	5.0	LED Backlight Anode
14	LED-	0	LED Backlight Cathode

n PART LIST

Part Name	Description	Quantity
IC	NT7701H-TABF3	1
IC	NT7702H-TABF4	1
IC	NJM064M-TE1-#ZZZB	1
IC	IT7001M/AY	1
IC	NT7701H-TABF3(TG656A)	2
IC	NT7702H-TABF4(TG656)	1
LCD	TSF1591-DFFDTW-P(4)	1
BACKLIGHT	WU209A-01	1

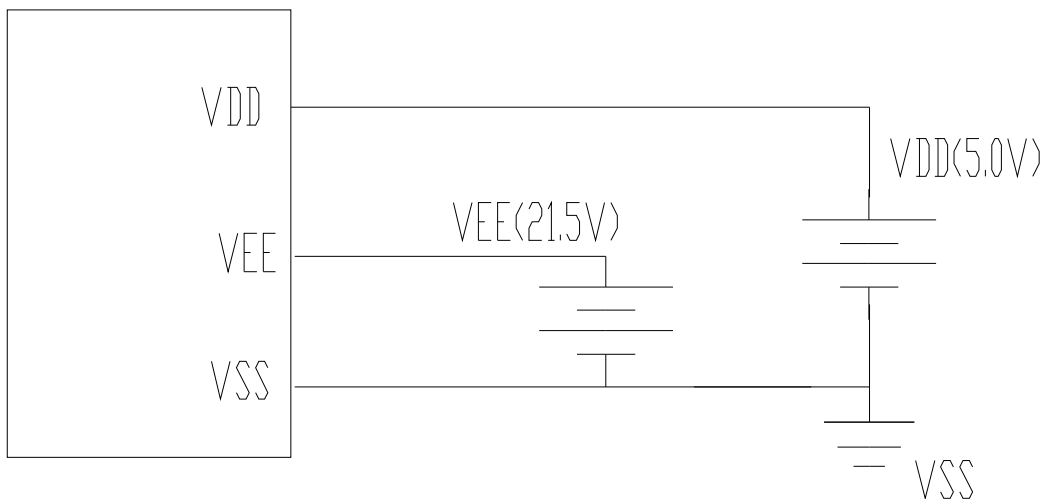
n APPLICATION CIRCUIT**n INITIAL CODE**

Please consult our technical department for detail information.

n ROHS STANDARD

TRULY® SEMICONDUCTORS LTD.

Test Items List

Customer: _____
 Company Name: Truly Semiconductors Ltd.
 Part Name: LCD Module
 Part No.: MFT-G320240DPSW-100W-E
 Date: 2006-2-17

No.	Material/Type Name	Test Items						Remark
		Cadmium and its compounds	Lead and its compounds	Mercury and its compounds	hexavalent chromium	Polybrominated Biphenyls	polybrominated Diphenyl ethers	
1	ITO Glass	<100ppm	<1000ppm	<1000ppm	<1000ppm	<1000ppm	<1000ppm	
2	Front Polarizer	<100ppm	<1000ppm	<1000ppm	<1000ppm	<1000ppm	<1000ppm	
3	Rear Polarizer	<100ppm	<1000ppm	<1000ppm	<1000ppm	<1000ppm	<1000ppm	
4	Seal	<100ppm	<1000ppm	<1000ppm	<1000ppm	<1000ppm	<1000ppm	
5	LC	<100ppm	<1000ppm	<1000ppm	<1000ppm	<1000ppm	<1000ppm	
6	IC	<100ppm	<1000ppm	<1000ppm	<1000ppm	<1000ppm	<1000ppm	
7	Resistor	<100ppm	<1000ppm	<1000ppm	<1000ppm	<1000ppm	<1000ppm	
8	Capacitance	<100ppm	<1000ppm	<1000ppm	<1000ppm	<1000ppm	<1000ppm	
9	ACF	<100ppm	<1000ppm	<1000ppm	<1000ppm	<1000ppm	<1000ppm	
10	Silica gel	<100ppm	<1000ppm	<1000ppm	<1000ppm	<1000ppm	<1000ppm	
11	Back Light	<100ppm	<1000ppm	<1000ppm	<1000ppm	<1000ppm	<1000ppm	
12	Casing	<100ppm	<1000ppm	<1000ppm	<1000ppm	<1000ppm	<1000ppm	
13	FFC	<100ppm	<1000ppm	<1000ppm	<1000ppm	<1000ppm	<1000ppm	
14	PCB	<100ppm	<1000ppm	<1000ppm	<1000ppm	<1000ppm	<1000ppm	

n RELIABILITY

◇ Content of Reliability Test

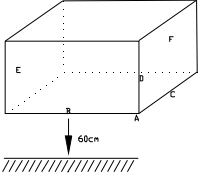
Environmental Test				
No.	Test Item	Content of Test	Test Condition	Applicable Standard
1	High temperature storage	Endurance test applying the high storage temperature for a long time.	80°C 200 hrs	-----
2	Low temperature storage	Endurance test applying the low storage temperature for a long time.	-30°C 200 hrs	-----
3	High temperature operation	Endurance test applying the electric stress (Voltage & Current) and the thermal stress to the element for a long time.	70°C 200 hrs	-----
4	Low temperature operation	Endurance test applying the electric stress under low temperature for a long time.	-20 °C 200 hrs	-----
5	High temperature / Humidity storage	Endurance test applying the high temperature and high humidity storage for a long time.	50°C , 90 %RH 96 hrs	
6	High temperature / Humidity operation	Endurance test applying the electric stress (Voltage & Current) and temperature / humidity stress to the element for a long time.	40°C , 90 %RH 96 hrs	
7	Temperature cycle	Endurance test applying the low and high temperature cycle. $ \begin{array}{c} -10^{\circ}\text{C} \rightleftharpoons 25^{\circ}\text{C} \rightleftharpoons 60^{\circ}\text{C} \\ 30\text{mi} \rightleftharpoons 5\text{min.} \rightleftharpoons 30\text{mi} \\ \leftarrow \hspace{10em} \rightarrow \\ \hspace{10em} 1 \text{ cycle} \end{array} $	-10°C /60°C 10 cycles	-----
Mechanical Test				
8	Vibration test	Endurance test applying the vibration during transportation and using.	10~55Hz → 1.5mmp-p X,Y,Z-axes Total 2/3hrs	
9	Shock test	Constructional and mechanical endurance test applying the shock during transportation.	 <p>every A、B、C、D、E、F、G fall down one time</p>	
Others				
10	Static electricity test	Endurance test applying the electric stress to the terminal.		

*** Supply voltage for logic system = VDD. Supply voltage for LCD system = Operating voltage at 25°C.

◇ Failure Judgement Criterion

Criterion Item	Failure Judgment Criterion										
	1	2	3	4	5	6	7	8	9	10	
Basic specification											Out of the Basic Specification
Electrical characteristic											Out of the DC and AC Characterstic
Mechanical characterstic											Out of the Mechanical Specification Color change : Out of Limit Apperance Specification
Optical characterstic											Out of the Apperance Standard

n QUALITY GUARANTEE

◇ Acceptable Quality Level

Each lot should satisfy the quality level defined as follows.

- Inspection method : MIL-STD-105E LEVEL II Normal one time sampling
- AQL

Partition	AQL	Definition
A: Major	0.4%	Functional defective as product
B: Minor	1.5%	Satisfy all functions as product but not satisfy cosmetic standard

◇ Definition of 'LOT'

One lot means the delivery quantity to customer at one time.

◇ Conditions of Cosmetic Inspection

I Environmental condition

The inspection should be performed at the 1m of height from the LCD module under 2 pieces of 40W white fluorescent lamps (Normal temperature 20~25°C and normal humidity 60±15%RH).

I Inspection method

The visual check should be performed vertically at more than 30cm distance from the LCD panel.

◇ Lifetime

Lifetime: 20 K hours within 10 years

INSPECTION CRITERIA

◇ Module Cosmetic Criteria

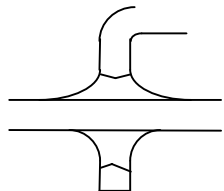
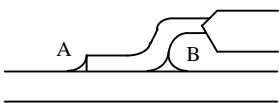
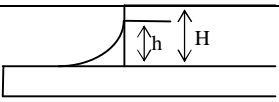
No.	Item	Judgement Criterion	Partition
1	Difference in Spec.	None allowed	Major
2	Pattern peeling	No substrate pattern peeling and floating	Major
3	Soldering defects	No soldering missing No soldering bridge No cold soldering	Major Major Minor
4	Resist flaw on substrate	Invisible copper foil ($\varnothing 0.5\text{mm}$ or more) on substrate pattern	Minor
5	Accretion of metallic Foreign matter	No soldering dust No accretion of metallic foreign matters (Not exceed $\varnothing 0.2\text{mm}$)	Minor Minor
6	Stain	No stain to spoil cosmetic badly	Minor
7	Plate discoloring	No plate fading, rusting and discoloring	Minor
8	Solder amount	<p>a. Soldering side of PCB Solder to form a 'Filet' all around the lead. Solder should not hide the lead form perfectly. (too much)</p>  <p>b. Components side (In case of 'Through Hole PCB') Solder to reach the Components side of PCB.</p>	Minor
	2. Flat packages	<p>Either 'Toe' (A) or 'Seal' (B) of the lead to be covered by 'Filet'.</p>  <p>Lead form to be assume over solder.</p>	Minor
	3. Chips	$(3/2) H \geq h \geq (1/2) H$ 	Minor

◇ Screen Cosmetic Criteria (Non-Operating)

No.	Defect	Judgement Criterion	Partition										
1	Spots	In accordance with <i>Screen Cosmetic Criteria (Operating) No.1.</i>	Minor										
2	Lines	In accordance with <i>Screen Cosmetic Criteria (Operating) No.2.</i>	Minor										
3	Bubbles in polarizer	<table border="1"> <thead> <tr> <th>Size : d mm</th> <th>Acceptable Qty in active area</th> </tr> </thead> <tbody> <tr> <td>$d \leq 0.3$</td> <td>Disregard</td> </tr> <tr> <td>$0.3 < d \leq 1.0$</td> <td>3</td> </tr> <tr> <td>$1.0 < d \leq 1.5$</td> <td>1</td> </tr> <tr> <td>$1.5 < d$</td> <td>0</td> </tr> </tbody> </table>	Size : d mm	Acceptable Qty in active area	$d \leq 0.3$	Disregard	$0.3 < d \leq 1.0$	3	$1.0 < d \leq 1.5$	1	$1.5 < d$	0	Minor
Size : d mm	Acceptable Qty in active area												
$d \leq 0.3$	Disregard												
$0.3 < d \leq 1.0$	3												
$1.0 < d \leq 1.5$	1												
$1.5 < d$	0												
4	Scratch	In accordance with spots and lines operating cosmetic criteria. When the light reflects on the panel surface, the scratches are not to be remarkable.	Minor										
5	Allowable density	Above defects should be separated more than 30mm each other.	Minor										
6	Coloration	Not to be noticeable coloration in the viewing area of the LCD panels. Back-lit type should be judged with back-lit on state only.	Minor										
7	Contamination	Not to be noticeable.	Minor										

◇ Screen Cosmetic Criteria (Operating)

No.	Defect	Judgement Criterion	Partition																				
1	Spots	<p>A) Clear</p> <table border="1"> <thead> <tr> <th>Size : d mm</th> <th>Acceptable Qty in active area</th> </tr> </thead> <tbody> <tr> <td>$d \leq 0.1$</td> <td>Disregard</td> </tr> <tr> <td>$0.1 < d \leq 0.2$</td> <td>6</td> </tr> <tr> <td>$0.2 < d \leq 0.3$</td> <td>2</td> </tr> <tr> <td>$0.3 < d$</td> <td>0</td> </tr> </tbody> </table> <p>Note : Including pin holes and defective dots which must be within one pixel size.</p> <p>B) Unclear</p> <table border="1"> <thead> <tr> <th>Size : d mm</th> <th>Acceptable Qty in active area</th> </tr> </thead> <tbody> <tr> <td>$d \leq 0.2$</td> <td>Disregard</td> </tr> <tr> <td>$0.2 < d \leq 0.5$</td> <td>6</td> </tr> <tr> <td>$0.5 < d \leq 0.7$</td> <td>2</td> </tr> <tr> <td>$0.7 < d$</td> <td>0</td> </tr> </tbody> </table>	Size : d mm	Acceptable Qty in active area	$d \leq 0.1$	Disregard	$0.1 < d \leq 0.2$	6	$0.2 < d \leq 0.3$	2	$0.3 < d$	0	Size : d mm	Acceptable Qty in active area	$d \leq 0.2$	Disregard	$0.2 < d \leq 0.5$	6	$0.5 < d \leq 0.7$	2	$0.7 < d$	0	Minor
Size : d mm	Acceptable Qty in active area																						
$d \leq 0.1$	Disregard																						
$0.1 < d \leq 0.2$	6																						
$0.2 < d \leq 0.3$	2																						
$0.3 < d$	0																						
Size : d mm	Acceptable Qty in active area																						
$d \leq 0.2$	Disregard																						
$0.2 < d \leq 0.5$	6																						
$0.5 < d \leq 0.7$	2																						
$0.7 < d$	0																						
2	Lines	<p>A) Clear</p> <p>Note : () - Acceptable Qty in active area L - Length (mm) W - Width (mm) ∞ - Disregard</p> <p>B) Unclear</p>	Minor																				

 'Clear' = The shade and size are not changed by V_o .

 'Unclear' = The shade and size are changed by V_o .

◇ Screen Cosmetic Criteria (Operating) (Continued)

No.	Defect	Judgement Criterion	Partition
3	Rubbing line	Not to be noticeable.	
4	Allowable density	Above defects should be separated more than 10mm each other.	Minor
5	Rainbow	Not to be noticeable.	Minor
6	Dot size	To be 95% ~ 105% of the dot size (Typ.) in drawing. Partial defects of each dot (ex. pin-hole) should be treated as 'Spot'. (see <i>Screen Cosmetic Criteria (Operating) No.1</i>)	Minor
7	Uneven brightness (only back-lit type module)	Uneven brightness must be $B_{MAX} / B_{MIN} \leq 2$ - B_{MAX} : Max. value by measure in 5 points - B_{MIN} : Min. value by measure in 5 points Divide active area into 4 vertically and horizontally. Measure 5 points shown in the following figure.	Minor

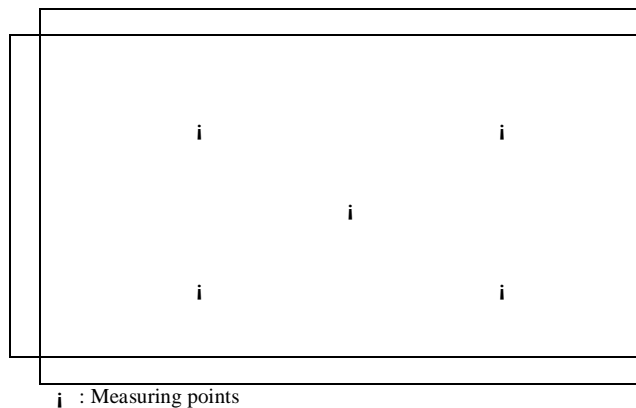

Note :

- (1) Size : $d = (\text{long length} + \text{short length}) / 2$
- (2) The limit samples for each item have priority.
- (3) Complexed defects are defined item by item, but if the number of defects are defined in above table, the total number should not exceed 10.
- (4) In case of 'concentration', even the spots or the lines of 'disregarded' size should not allowed. Following three situations should be treated as 'concentration'.
 - 7 or over defects in circle of $\varnothing 5\text{mm}$.
 - 10 or over defects in circle of $\varnothing 10\text{mm}$.
 - 20 or over defects in circle of $\varnothing 20\text{mm}$.

n PRECAUTIONS FOR USING LCD MODULES

◇ Handling Precautions

- (1) The display panel is made of glass. Do not subject it to a mechanical shock by dropping it or impact.
- (2) If the display panel is damaged and the liquid crystal substance leaks out, be sure not to get any in your mouth. If the substance contacts your skin or clothes, wash it off using soap and water.
- (3) Do not apply excessive force to the display surface or the adjoining areas since this may cause the color tone to vary.
- (4) The polarizer covering the display surface of the LCD module is soft and easily scratched. Handle this polarizer carefully.
- (5) If the display surface becomes contaminated, breathe on the surface and gently wipe it with a soft dry cloth. If it is heavily contaminated, moisten cloth with one of the following solvents :
 - Isopropyl alcohol
 - Ethyl alcohol
- (6) Solvents other than those above-mentioned may damage the polarizer. Especially, do not use the following.
 - Water
 - Ketone
 - Aromatic solvents
- (7) Exercise care to minimize corrosion of the electrode. Corrosion of the electrodes is accelerated by water droplets,

moisture condensation or a current flow in a high-humidity environment.

(8) Install the LCD Module by using the mounting holes. When mounting the LCD module make sure it is free of twisting, warping and distortion. In particular, do not forcibly pull or bend the I/O cable or the backlight cable.

(9) Do not attempt to disassemble or process the LCD module.

(10) NC terminal should be open. Do not connect anything.

(11) If the logic circuit power is off, do not apply the input signals.

(12) To prevent destruction of the elements by static electricity, be careful to maintain an optimum work environment.

- Be sure to ground the body when handling the LCD modules.

- Tools required for assembling, such as soldering irons, must be properly grounded.

- To reduce the amount of static electricity generated, do not conduct assembling and other work under dry conditions.

- The LCD module is coated with a film to protect the display surface. Exercise care when peeling off this protective film since static electricity may be generated.

◇ Storage Precautions

When storing the LCD modules, avoid exposure to direct sunlight or to the light of fluorescent lamps. Keep the modules in bags (avoid high temperature / high humidity and low temperatures below 0°C). Whenever possible, the LCD modules should be stored in the same conditions in which they were shipped from our company.

◇ Others

Liquid crystals solidify under low temperature (below the storage temperature range) leading to defective orientation or the generation of air bubbles (black or white). Air bubbles may also be generated if the module is subject to a low temperature.

If the LCD modules have been operating for a long time showing the same display patterns, the display patterns may remain on the screen as ghost images and a slight contrast irregularity may also appear. A normal operating status can be regained by suspending use for some time. It should be noted that this phenomenon does not adversely affect performance reliability.

To minimize the performance degradation of the LCD modules resulting from destruction caused by static electricity etc., exercise care to avoid holding the following sections when handling the modules.

- Exposed area of the printed circuit board.

- Terminal electrode sections.

n USING LCD MODULES

◇ Liquid Crystal Display Modules

LCD is composed of glass and polarizer. Pay attention to the following items when handling.

(1) Please keep the temperature within specified range for use and storage. Polarization degradation, bubble generation or polarizer peel-off may occur with high temperature and high humidity.

(2) Do not touch, push or rub the exposed polarizers with anything harder than an HB pencil lead (glass, tweezers, etc.).

(3) N-hexane is recommended for cleaning the adhesives used to attach front/rear polarizers and reflectors made of organic substances which will be damaged by chemicals such as acetone, toluene, ethanol and isopropylalcohol.

(4) When the display surface becomes dusty, wipe gently with absorbent cotton or other soft material like chamois soaked in petroleum benzin. Do not scrub hard to avoid damaging the display surface.

(5) Wipe off saliva or water drops immediately, contact with water over a long period of time may cause deformation or color fading.

(6) Avoid contacting oil and fats.

(7) Condensation on the surface and contact with terminals due to cold will damage, stain or dirty the polarizers. After products are tested at low temperature they must be warmed up in a container before coming in contact with room temperature air.

(8) Do not put or attach anything on the display area to avoid leaving marks on.

(9) Do not touch the display with bare hands. This will stain the display area and degrade insulation between terminals (some cosmetics are determined to the polarizers).

(10) As glass is fragile. It tends to become or chipped during handling especially on the edges. Please avoid dropping or jarring.

◇ Installing LCD Modules

The hole in the printed circuit board is used to fix LCM as shown in the picture below. Attend to the following items when installing the LCM.

(1) Cover the surface with a transparent protective plate to protect the polarizer and LC cell.

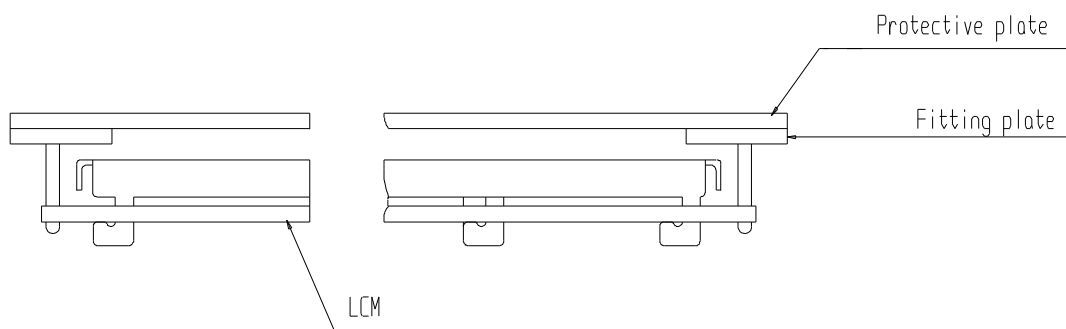

(2) When assembling the LCM into other equipment, the spacer to the bit between the LCM and the fitting plate should have enough height to avoid causing stress to the module surface, refer to the individual specifications for measurements. The measurement tolerance should be ± 0.1 mm.

◇ Precaution for Handling LCD Modules

Since LCM has been assembled and adjusted with a high degree of precision, avoid applying excessive shocks to the module or making any alterations or modifications to it.

(1) Do not alter, modify or change the the shape of the tab on the metal frame.

(2) Do not make extra holes on the printed circuit board, modify its shape or change the positions of components to be attached.

(3) Do not damage or modify the pattern writing on the printed circuit board.

(4) Absolutely do not modify the zebra rubber strip (conductive rubber) or heat seal connector.

(5) Except for soldering the interface, do not make any alterations or modifications with a soldering iron.

(6) Do not drop, bend or twist LCM.

◇ Electro-Static Discharge Control

Since this module uses a CMOS LSI, the same careful attention should be paid to electrostatic discharge as for an ordinary CMOS IC.

(1) Make certain that you are grounded when handling LCM.

(2) Before remove LCM from its packing case or incorporating it into a set, be sure the module and your body have the same electric potential.

(3) When soldering the terminal of LCM, make certain the AC power source for the soldering iron does not leak.

(4) When using an electric screwdriver to attach LCM, the screwdriver should be of ground potentiality to minimize as much as possible any transmission of electromagnetic waves produced sparks coming from the commutator of the motor.

(5) As far as possible make the electric potential of your work clothes and that of the work bench the ground potential.

(6) To reduce the generation of static electricity be careful that the air in the work is not too dried. A relative humidity of 50%-60% is recommended.

◇ Precaution for soldering to the LCM

(1) Observe the following when soldering lead wire, connector cable and etc. to the LCM.

- Soldering iron temperature : 280°C ± 10°C.
- Soldering time : 3-4 sec.
- Solder : eutectic solder.

If soldering flux is used, be sure to remove any remaining flux after finishing to soldering operation. (This does not apply in the case of a non-halogen type of flux.) It is recommended that you protect the LCD surface with a cover during soldering to prevent any damage due to flux spatters.

(2) When soldering the electroluminescent panel and PC board, the panel and board should not be detached more than three times. This maximum number is determined by the temperature and time conditions mentioned above, though there may be some variance depending on the temperature of the soldering iron.

(3) When remove the electroluminescent panel from the PC board, be sure the solder has completely melted, the soldered pad on the PC board could be damaged.

◇ **Storage**

When storing LCDs as spares for some years, the following precaution are necessary.

- (1) Store them in a sealed polyethylene bag. If properly sealed, there is no need for dessicant.
- (2) Store them in a dark place. Do not expose to sunlight or fluorescent light, keep the temperature between 0°C and 35°C.
- (3) The polarizer surface should not come in contact with any other objects. (We advise you to store them in the container in which they were shipped.)
- (4) Environmental conditions :
 - Do not leave them for more than 168hrs. at 90°C.
 - Should not be left for more than 48hrs. at -20°C.

◇ **Safety**

(1) It is recommended to crush damaged or unnecessary LCDs into pieces and wash them off with solvents such as acetone and ethanol, which should later be burned.

(2) If any liquid leaks out of a damaged glass cell and comes in contact with the hands, wash off thoroughly with soap and water.

◇ **Limited Warranty**

Unless agreed between TRULY and customer, TRULY will replace or repair any of its LCD modules which are found to be functionally defective when inspected in accordance with TRULY LCD acceptance standards (copies available upon request) for a period of one year from date of shipments. Cosmetic/visual defects must be returned to TRULY within 90 days of shipment. Confirmation of such date shall be based on freight documents. The warranty liability of TRULY limited to repair and/or replacement on the terms set forth above. TRULY will not be responsible for any subsequent or consequential events.

◇ **Return LCM under warranty**

No warranty can be granted if the precautions stated above have been disregarded. The typical examples of violations are :

- Broken LCD glass.
- PCB eyelet's damaged or modified.
- PCB conductors damaged.
- Circuit modified in any way, including addition of components.
- PCB tampered with by grinding, engraving or painting varnish.
- soldering to or modifying the bezel in any manner.

Module repairs will be invoiced to the customer upon mutual agreement. Modules must be returned with sufficient description of the failures or defects. Any connectors or cable installed by the customer must be removed completely without damaging the PCB eyelet's, conductors and terminals.

n PRIOR CONSULT MATTER

WE WILL ENFORCE OF CHANGING MATERIAL, METHOD, PROCESS AND OTHERS FOR THIS PRODUCT AFTER PRIOR CONSULTATION.

IF YOU HAVE DOUBTS ABOUT CONDITION OF RELIABILITY, WE WOULD CONFER WITH YOU.

n FACTORY

FACTORY NAME: TRULY SEMICONDUCTORS LTD.

FACTORY ADDRESS: Truly Industrial Area, ShanWei City,GuangDong,China

FACTORY PHONE: 86-0660-3380061 **FAX:** 86-0660-3371772