

FLZ CONNECTOR

Connectors for FPC

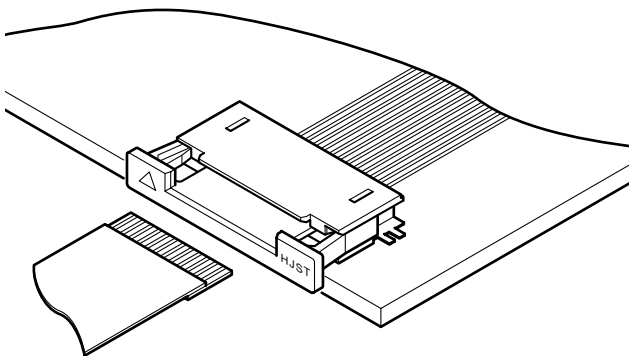

This extremely small 0.5mm (.020") pitch connector with a height of only 2.0mm (.079") above the PCB surface allows interconnection in extremely small spaces and is an example of JST's leading edge technology.



Features

• Zero insertion force mechanism

A ZIF mechanism increases wear resistance and extends the connector's mating life.

• Heat resistant design suitable for surface mounting

This housing is made of heat resistant plastic to allow reflow soldering.

• In-line surface mount tails

Has an in-line surface mount tails for easy inspection.

• Two types of connections

The connector is available in either the normal or reverse configurations. The FPC is positioned with its mating surfaces facing upward for the normal configured connector, while the reverse configuration requires that the FPC be positioned with its mating surfaces facing down. The engineer has greater freedom in designing his circuitry.

• Embossed tape for automatic mounting

The FLZ connector can be packaged in embossed tape for automatic mounting.

Specifications

- Current rating: 0.5A AC, DC
- Voltage rating: 50V AC, DC
- Temperature range: -25°C to +85°C
(including temperature rise in applying electrical current)
- Contact resistance: Initial value/40m Ω max.
After environmental testing/60m Ω max.
- Insulation resistance: 800M Ω min.
- Withstanding voltage: 200V AC/minute
- Applicable FPC: Lead pitch/0.5mm(.020")
Lead width/0.35mm(.140")
Mating part thickness/
0.30±0.03mm(.012" ± .001")

<Note>FPC to be actually used should be checked for applicability.

- * Contact JST if Lead-Free product is required.
- * Refer to "General Instruction and Notice when using Terminals and Connectors" at the end of this catalog.
- * Contact JST for details.

Standards

- Recognized E60389
- 1 Certified LR20812

Connector

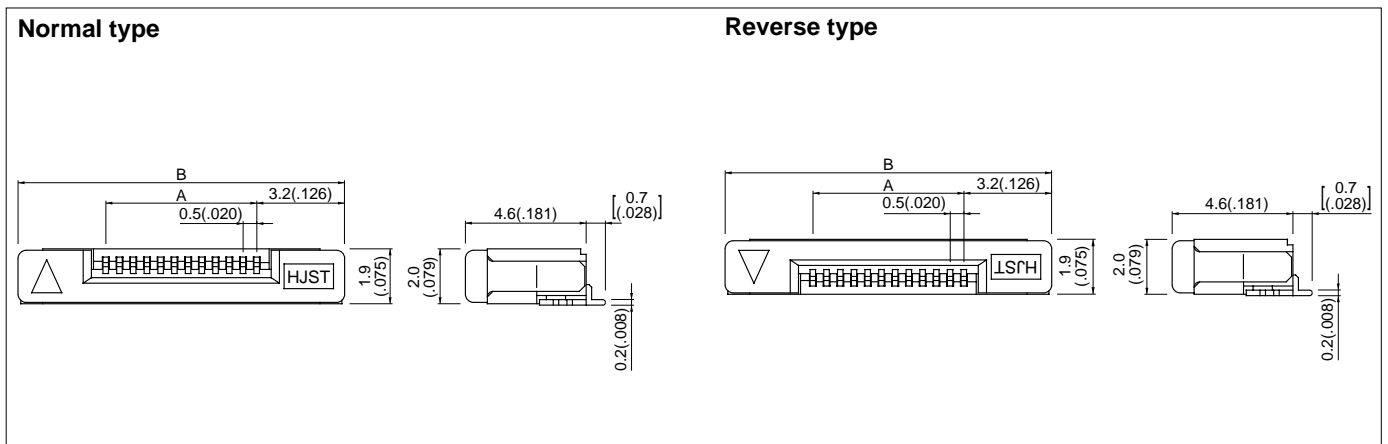

Cir- cuits	Model No.		Dimensions mm(in.)		Q'ty / reel
	Normal type	Reverse type	A	B	
6	06FLZ-SM1-TB	06FLZ-RSM1-TB	2.5(.098)	8.9(.350)	2,000
7	07FLZ-SM1-TB	07FLZ-RSM1-TB	3.0(.118)	9.4(.370)	2,000
8	08FLZ-SM1-TB	08FLZ-RSM1-TB	3.5(.138)	9.9(.390)	2,000
9	09FLZ-SM1-TB	09FLZ-RSM1-TB	4.0(.157)	10.4(.409)	2,000
10	10FLZ-SM1-TB	10FLZ-RSM1-TB	4.5(.177)	10.9(.429)	2,000
11	11FLZ-SM1-TB	11FLZ-RSM1-TB	5.0(.197)	11.4(.449)	2,000
12	12FLZ-SM1-TB	12FLZ-RSM1-TB	5.5(.217)	11.9(.469)	2,000
13	13FLZ-SM1-TB	13FLZ-RSM1-TB	6.0(.236)	12.4(.488)	2,000
14	14FLZ-SM1-TB	14FLZ-RSM1-TB	6.5(.256)	12.9(.508)	2,000
15	15FLZ-SM1-TB	15FLZ-RSM1-TB	7.0(.275)	13.4(.527)	2,000
16	16FLZ-SM1-TB	16FLZ-RSM1-TB	7.5(.296)	13.9(.547)	2,000
18	18FLZ-SM1-TB	18FLZ-RSM1-TB	8.5(.335)	14.9(.587)	2,000
20	20FLZ-SM1-TB	20FLZ-RSM1-TB	9.5(.374)	15.9(.626)	2,000
21	21FLZ-SM1-TB	21FLZ-RSM1-TB	10.0(.394)	16.4(.646)	2,000
22	22FLZ-SM1-TB	22FLZ-RSM1-TB	10.5(.413)	16.9(.665)	2,000
23	23FLZ-SM1-TB	23FLZ-RSM1-TB	11.0(.433)	17.4(.685)	2,000
24	24FLZ-SM1-TB	24FLZ-RSM1-TB	11.5(.453)	17.9(.705)	2,000
25	25FLZ-SM1-TB	25FLZ-RSM1-TB	12.0(.472)	18.4(.724)	2,000
26	26FLZ-SM1-TB	26FLZ-RSM1-TB	12.5(.492)	18.9(.744)	2,000
27	27FLZ-SM1-TB	27FLZ-RSM1-TB	13.0(.512)	19.4(.764)	2,000
28	28FLZ-SM1-TB	28FLZ-RSM1-TB	13.5(.531)	19.9(.783)	2,000
30	30FLZ-SM1-TB	30FLZ-RSM1-TB	14.5(.571)	20.9(.823)	2,000
33	33FLZ-SM1-TB	-	16.0(.630)	22.4(.882)	2,000

Material and Finish

Contact: Phosphor bronze, tin/lead-plated
 Slider housing: Nylon 46, UL94V-0 (black)
 Receptacle housing: Nylon 46, UL94V-0
 ()FLZ-SM1-TB, gray
 ()FLZ-RSM1-TB, natural
 Solder tab: Phosphor bronze, tin/lead-plated

Note: The products listed above are supplied on embossed tape.

FLZ CONNECTOR

Connector <Inner-lock type>

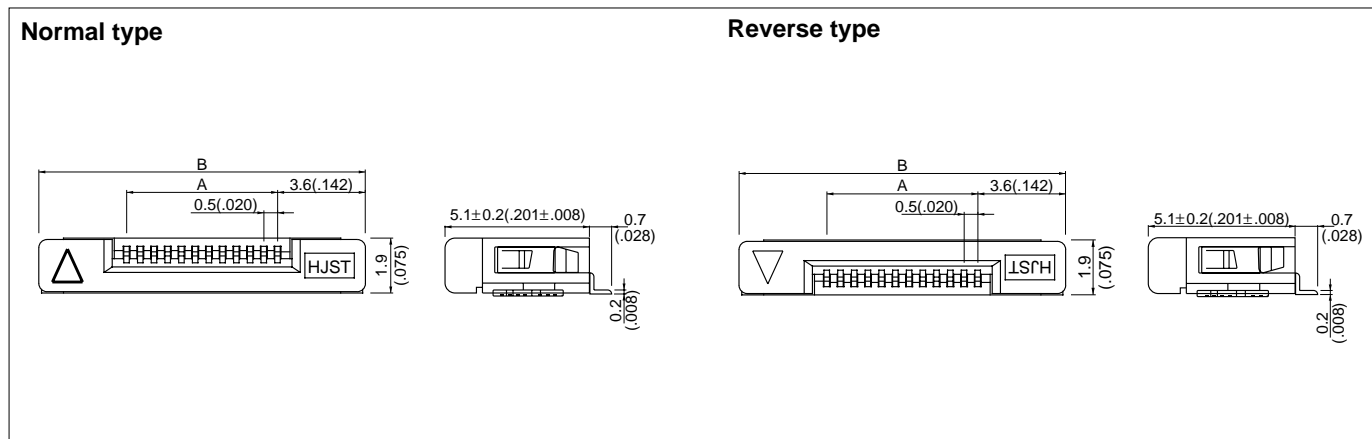

Circuits	Model No.		Dimensions mm(in.)		Q'ty / reel
	Normal type	Reverse type	A	B	
13	-	13FLZ-RSM1-R-TB	6.0(.236)	13.1(.516)	2,000
32	32FLZ-SM1-R-TB	32FLZ-RSM1-R-TB	15.5(.610)	22.6(.890)	2,000
34	34FLZ-SM1-R-TB	34FLZ-RSM1-R-TB	16.5(.650)	23.6(.929)	2,000
36	36FLZ-SM1-R-TB	36FLZ-RSM1-R-TB	17.5(.689)	24.6(.969)	2,000
40	40FLZ-SM1-R-TB	40FLZ-RSM1-R-TB	19.5(.768)	26.6(1.047)	2,000
42	42FLZ-SM1-R-TB	-	20.5(.807)	27.6(1.087)	2,000
45	45FLZ-SM1-R-TB	-	22.0(.866)	29.1(1.146)	2,000
50	50FLZ-SM1-R-TB	-	24.5(.965)	31.6(1.244)	2,000

Material and Finish

Contact: Phosphor bronze, tin/lead-plated
 Slider housing: Nylon 46, UL94V-0 (black)
 Receptacle housing: Nylon 46, UL94V-0
 ()FLZ-SM1-R-TB, gray
 ()FLZ-RSM1-R-TB, natural
 Solder tab: Phosphor bronze, tin/lead-plated

Note: 1. The products listed above are supplied on embossed tape.
 2. 45FLZ-SM1-R-TB and 50FLZ-SM1-R-TB are not UL/CSA approved.

Taping specifications

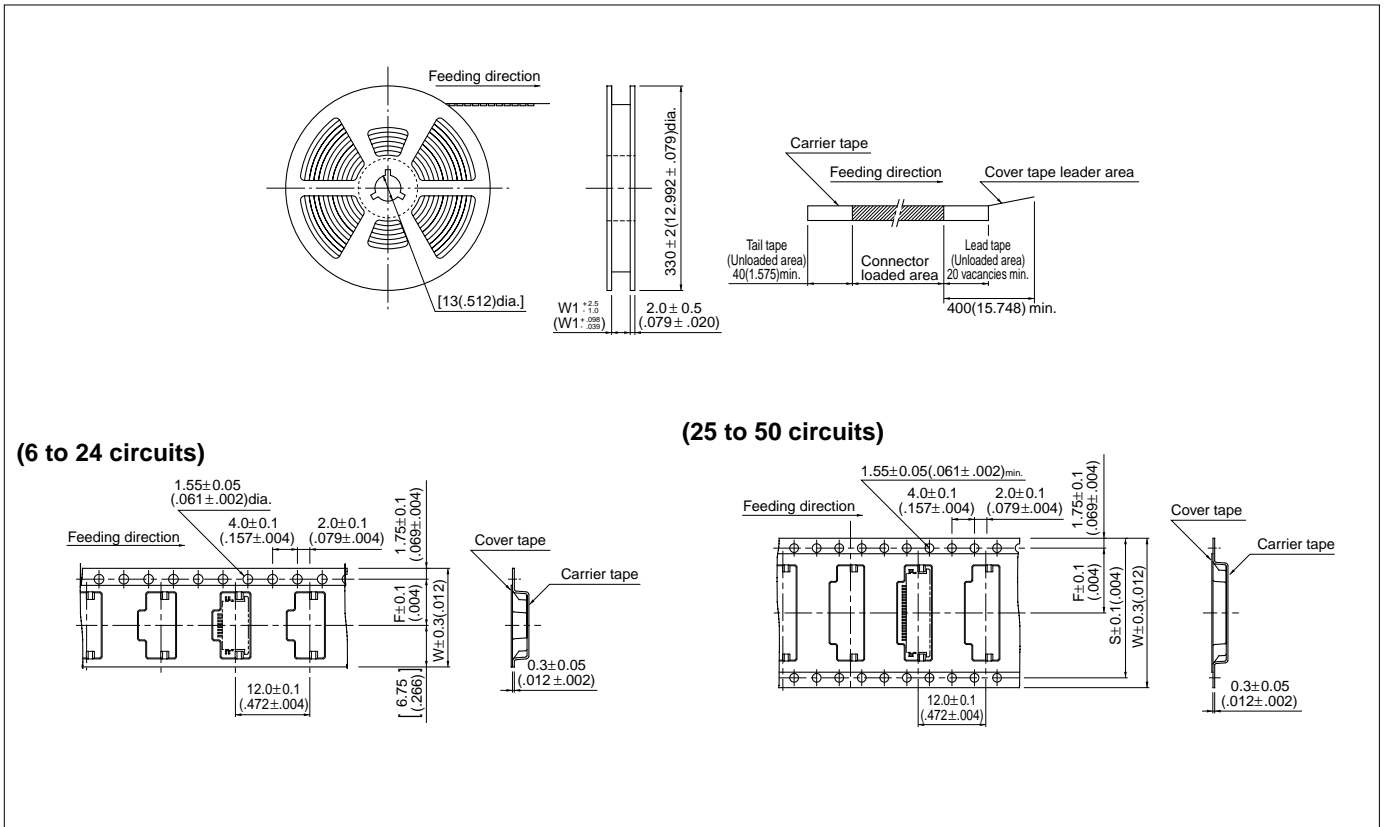

Circuits	Taping dimensions mm(in.)			Reel dimensions mm(in.)	Q'ty / reel
	F	S	W		
6 to 8	7.5(.295)	-	16.0(.630)	17.5(.689)	2,000
9 to 24	11.5(.435)	-	24.0(.945)	25.5(1.004)	2,000
30	14.2(.559)	28.4(1.118)	32.0(1.260)	33.5(1.319)	2,000
32 to 50	20.2(.795)	40.4(1.591)	44.0(1.732)	45.5(1.791)	2,000

Note:

- Specifications conform to JIS C 0806. The tape width, connector recess dimensions, etc. are determined by the number of circuits and external shape of the connector to be loaded.
- Specifications are subject to change without prior notice.

Lead section dimensions of FPC

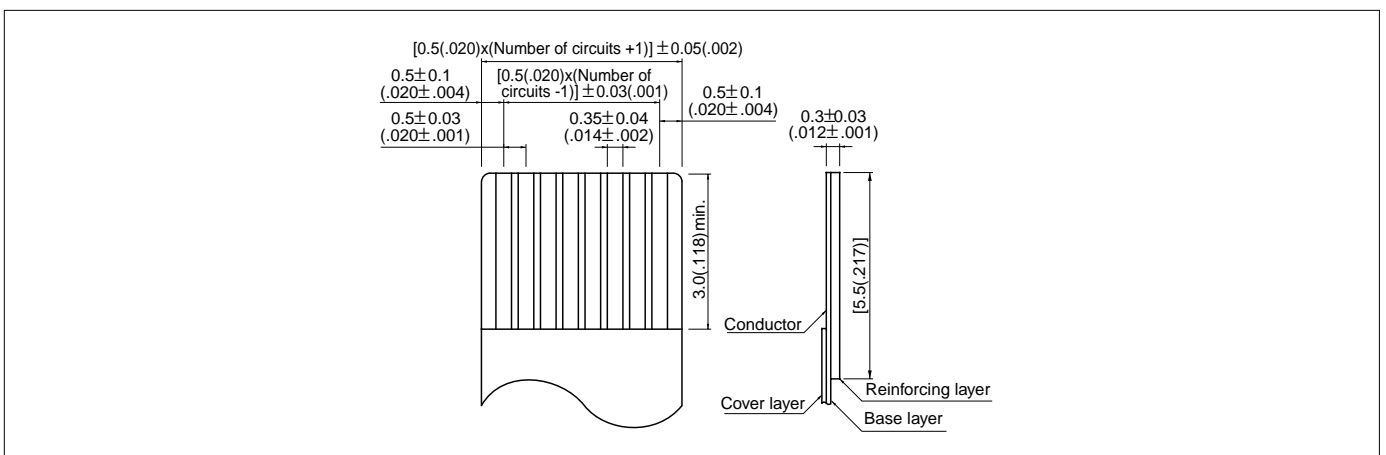

FLZ CONNECTOR

PC board layout (viewed from component side) and Assembly layout

(6 to 33 circuits)

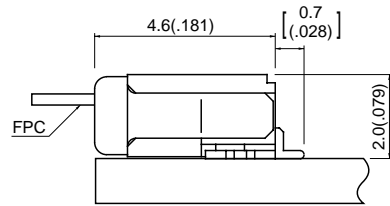
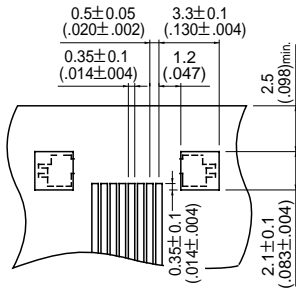

(13 to 50 circuits) <Inner-lock type>

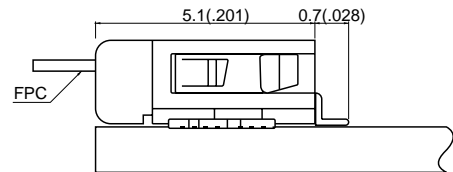
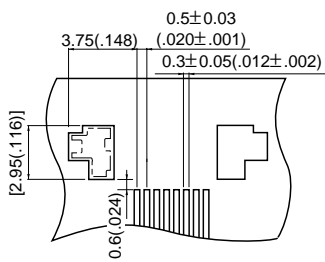

Note:

1. Tolerances are non-cumulative: $\pm 0.03\text{mm}(\pm 0.001")$ for all centers.
2. The dimensions above should serve as a guideline.
Contact JST for details.