

PRODUCT : Optical Finger Navigation Module**MODEL NO.** : OFN8001FO-E**SUPPLIER** : TRULY OPTO-ELECTRONICS LTD.**DATE** : January 4, 2011

CERT. No. 946535
ISO9001
TL9000



*ROHS
LEAD-FREE*

SPECIFICATION

Revision: 1.1

OFN8001FO-E

If there is no special request from customer, TRULY OPTO-ELECTRONICS LTD. will not reserve the tooling of the product under the following conditions:

1. There is no response from customer in two years after TRULY OPTO-ELECTRONICS LTD. submit the samples;

2. There is no order in two years after the latest mass production.

And correlated data (include quality record) will be reserved one year more after tooling was discarded.

TRULY OPTO-ELECTRONICS LTD.: **CUSTOMER:**

Quality Assurance Department: _____

Approved by:

Technical Department: _____

Customer

Approved by:

CONTENTS

n KEY INFORMATION

n PIN ASSIGNMENT

n MECHANICAL DRAWING

n CIRCUIT DIAGRAM

n ELECTRICAL CHARACTERISTICS

n MODULE APPLICATION NOTE

n PACKAGE SPECIFICATION

n PRIOR CONSULT MATTER

n FACTORY CONTACT INFORMATION

Key Information

Module No.		OFN8001FO-E
Module Size		8.2mm x 8.2mm x 4.1mm
Sensor Type		Integrated package
Power supply	DVDD	1.65V~1.95V
	VDDA	2.6V~3.3V
	VDDIO	1.65V~3.3V
Features		<ul style="list-style-type: none"> - Low power architecture - Self-adjusting power-saving modes for longer battery life - High speed motion detection up to TBDips - Self-adjusting frame rate for optimum performance - Motion detect pin output - Finger detect pin output - Internal oscillator-no clock input needed - Selectable 250,500,750,1000 and 1250 cpi resolution - Integrated chip-on-board LED with wavelength of 870nm - Integrated Dome switch
Interface type		Two wire interface (TWI)
Temperature Range	Operation	-20°C~70°C
	Storage	-30°C~80°C

Pin Assignment

No.	Name	Input/Output	Description
1	GND		Ground
2	MOTION	O	Motion detect
3	VDDA		Analog Voltage input
4	GND		Ground
5	DVDD		Digital Input voltage
6	DOME-		Dome -
7	DOME+		Dome+
8	VDDIO		Voltage for I/O
9	SHTDWN	I	Shutdown
10	IO_CLK	I	Serial clock input
11	IO_MISO_SDA	I/O	TWI serial data or Master In Slave Out
12	NRST	I	Hardware Chip Reset

Note:

SPI: Serial Peripheral interface. IO_select pin is SPI mode selection; IO_NCS_A1 pin is chip select; IO_CLK pin is serial clock input; IO_MISO_SDA and IO_MOSI_A0 pin are data communications.

TWI: Two - Wire Interface. IO_select pin is TWI mode selection. IO_CLK pin is serial clock input; IO_MISO_SDA pin is data communications; IO_MOSI_A0 and IO_NCS_A1 pin are TWI slave address setting.

Mechanical Drawing

ROHS

OPN8001F0-E Module

Customer No.:

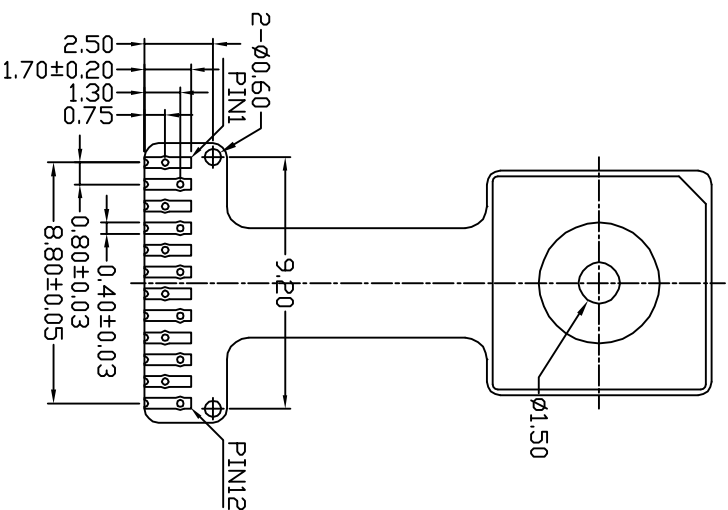
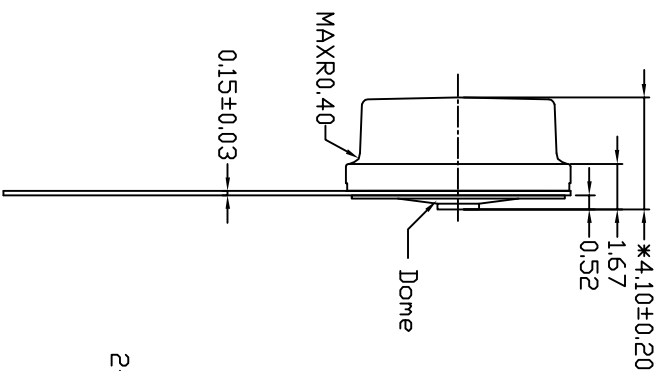
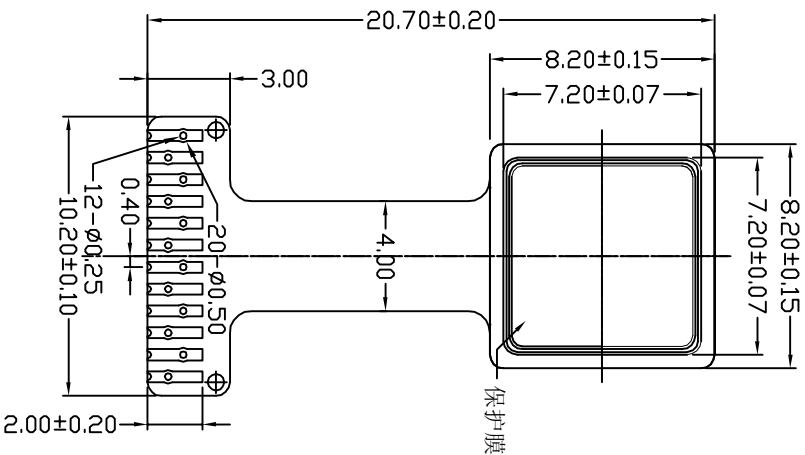

DVDD(1.65~1.95V)
AVDD(2.6~3.3V)
DDVDD(1.65~3.3V)

NOTE:

1. * : CRITICAL DIMENSIONS;
2. UNSPECIFIED TOLANCE:±0.10
3. UNSPECIFIED CHAMFER:R=0.2;

12PIN DESCRIPTION

PIN NO	NAME
1	GND
2	MOTION
3	VDDA
4	GND
5	DVDD
6	DOME-
7	DOME+
8	VDDID
9	SHTDWN
10	ID_CLK
11	ID_MISO_SDA
12	NRSST

CUSTOMER APPROVE		AMEND		光学控制器	
Mechanical	Electrical			TOLERANCE DECIMAL	PRODUCT NO.
△	△			*x ± .30	OPN8001F0-E
△	△			xx ± .20	DWN 林华苗 20100919
△	△	修改保护膜	20101129	≤ ± 1/4	DSN 林华苗 20100919
		CONTENT	DATE		CHKD 韦有兴 20100919 APPD 刘铁楠 20100919
					NOT IN SCALE UNIT mm SHEET:

TRULY OPTO-ELECTRONICS LTD.

DRAW NO. REV

B

Circuit Diagram

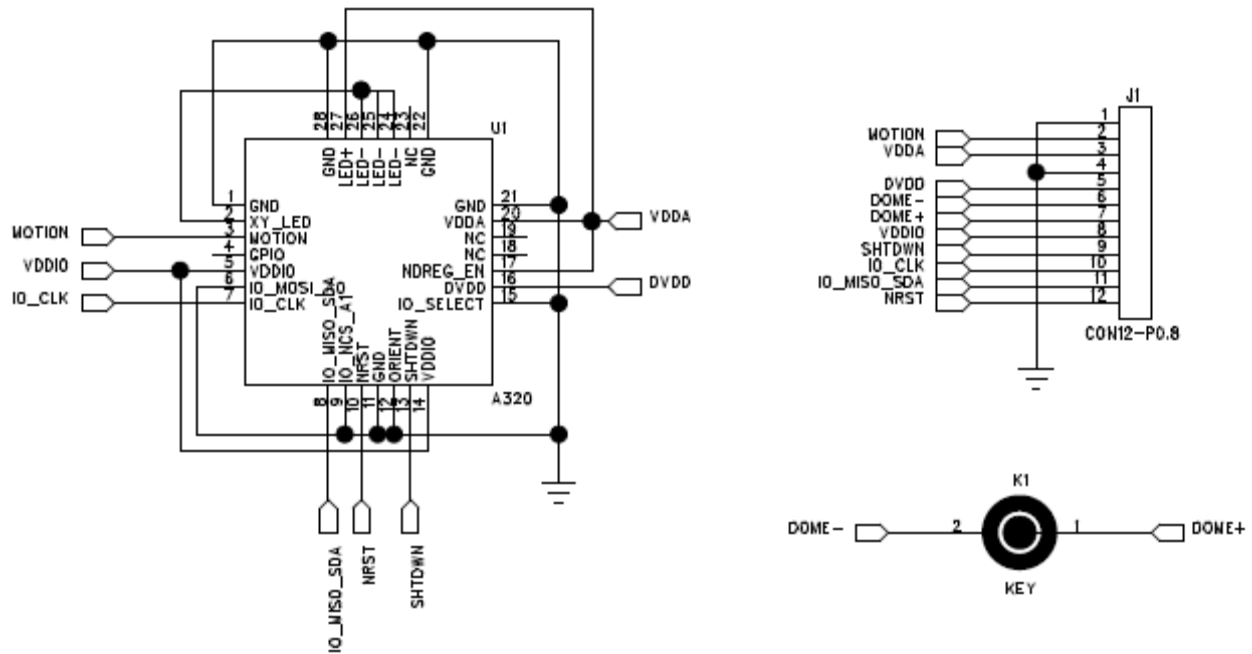

Electrical Characteristic

1. Absolute Maximum Ratings

Parameter	Symbol	Minimum	Maximum	Units	Notes
Storage Temperature	T _S	-40	85	°C	
Lead Solder Temp			260	°C	For 1.4 seconds
Moisture Sensitivity Level	MSL		1		Referring to JEDEC-J-STD-020.
Analog Supply Voltage	V _{DDA}	2.6	3.6	V	
I/O Supply Voltage	V _{DDIO}	1.65	3.6	V	
Digital Supply Voltage	DV _{DD}	1.65	2	V	
LED supply voltage	V _{LED+}	2.6	3.6	V	
ESD (sensor only)			2	kV	All pins, human body model JESD22-A114-E
Input Voltage	V _{IN}	-0.5	V _{DDA} +0.5 V _{DDIO} +0.5	V	nDREG_EN pin All pins except nDREG_EN pin
Latchup Current	I _{out}		20	mA	All Pins

At power up, if DV_{DD} is powered up before V_{DDA}, DV_{DD} should never exceed V_{DDA} by more than 0.7V to avoid high inrush current. If DV_{DD} is powered up before V_{DDA}, then V_{DDA} must ramp up to stable voltage in less than 1.5seconds. In this case high inrush current of up to 180mA can be observed at DV_{DD}.

At power down, if V_{DDA} is powered down before DV_{DD} and V_{DDIO}, then DV_{DD} must ramp down to 0V in less than 1.5seconds. In this case high inrush current of up to 180mA can be observed at DV_{DD}.

2.Recommended Operating Conditions

Parameter	Symbol	Minimum	Typical	Maximum	Units	Notes
Operating Temperature	T _A	-20		60	°C	
Analog supply voltage	V _{DDA}	2.6	2.8	3.3	Volts	Including V _{NA} noise.
I/O supply voltage	V _{DDIO}	1.65	1.8 or 2.8	3.3	Volts	Including V _{NA} noise. Sets I/O voltages but not for nDREG_EN. See fig 7a, 7b.
Digital supply voltage	DV _{DD}	1.65	1.8	1.95	Volts	Input voltage supply when nDREG pin is high. Input voltage supply not required when nDREG is GND
LED supply voltage	V _{LED+}	2.6	2.8	3.3	Volts	Including V _{NA} noise.
Power supply rise time	t _{VRT}	0.001		100	ms	0 to 2.8V
Supply noise (Sinusoidal)	V _{NA}			100	mV p-p	10kHz-50MHz
Speed	S			15	in/sec	Using prosthetic finger as surface

3.AC Electrical Specifications

Electrical Characteristics over recommended operating conditions. Typical values at 25°C, V_{DDA}=2.8V, DV_{DD}=1.8V.

Parameter	Symbol	Minimum	Typical	Maximum	Units	Notes
Motion delay after reset	t _{MOT-RST}	3.5		23	ms	From Hard or Soft_RESET register write to valid register write/read and motion, assuming motion is present
Shutdown	t _{SHTDWN}			50	ms	From SHTDWN pin active to low current
Wake from shutdown	t _{WAKEUP}	100			ms	From SHTDWN pin inactive to valid motion. Refer to section "Notes on Shutdown"; also note t _{MOT-RST}
MOTION rise time	t _{r-MOTION}		150	300	ns	C _L = 100pF
MOTION fall time	t _{f-MOTION}		150	300	ns	C _L = 100pF
SHTDWN pulse width	t _{p-SHTDWN}	150			ms	
NRST pulse width	t _{NRST}	20			us	From edge of valid NRST pulse
Reset wait time after stable supply voltage	t _{VRT-NRST}	100			ms	
Transient Supply Current	I _{DDT}			75	mA	Max supply current for 500 usec for each supply voltages ramp from 0 to 3.3V

4.DC Electrical Specifications

Electrical Characteristics over recommended operating conditions. Typical values at 25°C, $V_{DDA}=3.3V$, $DV_{DD}=1.95V$ at default LED setting 13mA.

Parameter		Internal regulator Enabled		Internal regulator Disabled		Units	Notes
		Typical	Max	Typical	Max		
DC average supply current in Run mode	$I_{V_{DDA}}$	1.80	2.50	0.90	1.10	mA	GPIO=SHTDWN=pull low, IO_MISO=NRST=ORIENT=pull high.
	I_{DD_LED+}	1.30	1.80	1.30	1.80	mA	GPIO=SHTDWN=pull low, IO_MISO=NRST=ORIENT=pull high.
	$I_{DV_{DD}}$	0	0	0.90	1.40	mA	GPIO=SHTDWN=pull low, IO_MISO=NRST=ORIENT=pull high.
	Total	3.10	4.30	3.10	4.30	mA	
DC average supply current in Rest1 mode	$I_{V_{DDA}}$	0.20	0.30	0.10	0.15	mA	GPIO=SHTDWN=pull low, IO_MISO=NRST=ORIENT=pull high.
	I_{DD_LED+}	0.20	0.40	0.20	0.40	mA	GPIO=SHTDWN=pull low, IO_MISO=NRST=ORIENT=pull high.
	$I_{DV_{DD}}$	0	0	0.10	0.15	mA	GPIO=SHTDWN=pull low, IO_MISO=NRST=ORIENT=pull high.
	Total	0.40	0.70	0.40	0.70	mA	
DC average supply current in Rest2 mode	$I_{V_{DDA}}$	0.06	0.12	0.03	0.07	mA	GPIO=SHTDWN=pull low, IO_MISO=NRST=ORIENT=pull high.
	I_{DD_LED+}	0.04	0.08	0.04	0.08	mA	GPIO=SHTDWN=pull low, IO_MISO=NRST=ORIENT=pull high.
	$I_{DV_{DD}}$	0	0	0.03	0.05	mA	GPIO=SHTDWN=pull low, IO_MISO=NRST=ORIENT=pull high.
	Total	0.10	0.20	0.10	0.20	mA	
DC average supply current in Rest3 mode	$I_{V_{DDA}}$	0.03	0.12	0.02	0.06	mA	GPIO=SHTDWN=pull low, IO_MISO=NRST=ORIENT=pull high.
	I_{DD_LED+}	0.01	0.03	0.01	0.03	mA	GPIO=SHTDWN=pull low, IO_MISO=NRST=ORIENT=pull high.
	$I_{DV_{DD}}$	0	0	0.01	0.06	mA	GPIO=SHTDWN=pull low, IO_MISO=NRST=ORIENT=pull high.
	Total	0.04	0.15	0.04	0.15	mA	
Analog shutdown supply current	I_{DD_SHTDWN} V_{DDA}	17	44.3	0	2	μA	GPIO=pull low, SHTDWN=IO_MISO=NRST=ORIENT=pull high.
Analog shutdown supply current	I_{DD_SHTDWN} V_{LED+}	0	0.7	0	0.7	μA	GPIO=pull low, SHTDWN=IO_MISO=NRST=ORIENT=pull high.
Digital shutdown supply current	I_{DD_SHTDWN} DV_{DD}	0	0	3	15	μA	GPIO=pull low, SHTDWN=IO_MISO=NRST=ORIENT=pull high.

Parameter	Symbol	Minimum	Typical	Maximum	Units	Notes
V _{DDIO} DC Supply Current	I _{VDDIO}			10	uA	Average current V _{DDIO} .
Analog peak supply current	I _{PEAK} V _{DDA}			2.5	mA	At LED register setting of 40mA.
LED+ peak supply current	I _{PEAK} LED+			49.5	mA	At LED register setting of 40mA.
Digital Peak supply current	I _{PEAK} DV _{DD}			1.5	mA	At LED register setting of 40mA.
Input Low Voltage	V _{IL}	-0.05	0	V _{DDIO} *0.35	V	IO_MOSI_A0, IO_CLK, IO_MISO_SDA, IO_NCS_A1, NRST, ORIENT, SHTDWN, IO_SELECT
Input High Voltage	V _{IH}	V _{DDIO} * 0.7	V _{DDIO}	V _{DDIO} +0.05	V	IO_MOSI_A0, IO_CLK, IO_MISO_SDA, IO_NCS_A1, NRST, ORIENT, SHTDWN, IO_SELECT
Input hysteresis	V _{HYS}	100			mV	
Input leakage current	I _{leak}		±1	±10	μA	IO_MOSI_A0, IO_CLK, IO_MISO_SDA, IO_NCS_A1, NRST, ORIENT, SHTDWN, IO_SELECT
Output Low Voltage	V _{OL}			0.2	V	I _{out} =1.2mA
Output High Voltage	V _{OH}	V _{DDIO} -0.2	V _{DDIO} -0.1		V	I _{out} =600uA
Input Capacitance	C _{in}			10	pF	MOSI, NCS, SCLK, SHTDWN

5.Dome Specifications

Parameter	Symbol	Minimum	Typical	Maximum	Units	Notes
Contact resistance				1	ohm	
Debounce				10	ms	
Operating force		1.2	1.6	2.0	N	Newton force
Travel distance		0.1	0.2	0.3	mm	

Note: For more information of sensor please refer to the ADBS-A320 specification.

Module Application Note

1. Notes on Power-up

The module does not perform an internal power up self-reset; the NRST pin must be toggled every time power is applied. The appropriate sequence is as follows:

- (1) Apply power. For single voltage supply (internal regulator enabled), apply V_{DDA}(2.8V). For dual voltage supply (internal regulator disabled), apply V_{DDA}(2.8V) first then followed by DV_{DD}(1.8V),
- (2) Set NCS, Shutdown, Orient and IO_select pin to low (for TWI) or high (for SPI).
- (3) If in TWI mode, set A0 and A1 according to the Table TWI slave address in datasheet. This step is skipped if SPI mode is used.
- (4) Drive NRST low then high(TWI slave address will only be selected after a NRST toggle is applied when A0 and A1 is set).
- (5) Perform soft reset (writing 0x5A to address 0x3a).
- (6) During power-up and reset, other pins' state is below:

Pin	NCS high before reset	NCS Low before reset	After Reset
NCS	High	Low	Functional
SCLK	Ignored	Functional	Depends on NCS
MISO	Undefined	Functional	Depends on NCS
MOSI	Ignored	Functional	Depends on NCS
MOTION	Undefined	Undefined	Functional
SHTDWN	Must be low	Must be low	Functional
NRST	High	High	High

2. Notes on SPI Mode

The port is a four wire serial port. The host micro-controller always initiates communication; the module never initiates data transfers. SCLK, MOSI, and NCS may be driven directly by a micro-controller. The port pins may be shared with other SPI slave devices. When the NCS pin is high, the inputs are ignored and the output is tri-stated.

The lines that comprise the SPI port:

SCLK: Clock input. It is always generated by the master (the micro-controller)

MOSI: Input data. (Master Out/Slave In)

MISO: Output data. (Master In/Slave Out)

NCS: Chip select input (active low). NCS needs to be low to activate the serial port; otherwise, MISO will be high Z, and MOSI & SCLK will be ignored. NCS can also be used to reset the serial port in case of an error.

3. Notes on TWI Mode

The port is a two wire serial port. IO_CLK is Serial clock input and IO_SDA is serial data.

The sensor responds to one of the following selectable slave device addresses depending on the IO_A0 and IO_A1 input pin state. These pins should be set to avoid conflict with any other devices that might be sharing the bus.

IO_A0	IO_A1	Slave Address (Hex)
0	0	33
0	1	37
0	NC	3B
1	0	53
1	1	57
1	NC	5B
NC	0	63
NC	1	67
NC	NC	6B

4. Notes on Chip Select Operation

The serial port is activated after NCS goes low. If NCS is raised during a transaction, the entire transaction is aborted and the serial port will be reset. This is true for all transactions. After a transaction is aborted, the normal address-to-data or transaction-to-transaction delay is still required before beginning the next transaction. To improve communication reliability, all serial transactions should be framed by NCS. In other words, the port should not remain enabled during periods of non-use because ESD and EFT/B events could be interpreted as serial communication and put the chip into an unknown state. In addition, NCS must be raised after each burst-mode transaction is complete to terminate burst-mode. The port is not available for further use until burst-mode is terminated.

5. Notes on Shutdown and Reset

The module can be set in shutdown mode by asserting or set SHTDWN pin high. During the shutdown state, all input voltages VDDA, VDDIO and DVDD must be maintained above the minimum level. If these conditions are not met, then the sensor must be restarted by powering down then powering up again for proper operation. For proper operation, SHTDWN pulse width must be at least tP-SHTDWN. Shorter pulse widths may cause the chip to enter an undefined state. In addition, the SPI port should not be accessed when SHTDWN is asserted.

6. Notes on Write Operation

Write operation, defined as data going from the micro-controller to the module, is always initiated by the micro-controller and consists of two bytes. The first byte contains the address (seven bits) and has a "1" as its MSB to indicate data direction. The second byte contains the data. The module reads MOSI on rising edges of SCLK.

7. Notes on Read Operation

A read operation, defined as data going from the module to the micro-controller, is always initiated by the micro-controller and consists of two bytes. The first byte contains the address, is sent by the micro-controller over MOSI, and has a "0" as its MSB to indicate data direction. The second byte contains the data and is driven by the module over MISO. The sensor outputs MISO bits on falling edges of SCLK and samples MOSI bits on every rising edge of SCLK.

Note: For more module application information please refer to the ADBS-A320 specification.

Software Recommendation

1. During continuous movement, the time interval between two key events should not exceed 250ms;
2. To ensure that sufficient data can be collected even in fast-moving conditions, the sampling time should not exceed 30ms.

Package Specification

Product No.	OFN8001FO-E	Release date					
Product name	Compact Camera Module	Releaser					
Supplier	TRULY OPTO-ELECTRONICS LTD.	Recycle	<input type="checkbox"/> YES <input checked="" type="checkbox"/> NO				
Quantity/ each box	TBD	Material for box	<input checked="" type="checkbox"/> paper <input type="checkbox"/> plastic				
Outer carton box size	405 mm *290 mm *170 mm	Box type	<input checked="" type="checkbox"/> new <input type="checkbox"/> update				
Quantity / inner box * Quantity / outer box	TBD	Weig ht	<table border="1"> <tr> <td>g / pcs</td> <td rowspan="2">BOX=TYPE Record of SRF Dept.</td> <td rowspan="2">TBD Kg(Max)</td> </tr> <tr> <td>Kg / outer box</td> </tr> </table>	g / pcs	BOX=TYPE Record of SRF Dept.	TBD Kg(Max)	Kg / outer box
g / pcs	BOX=TYPE Record of SRF Dept.	TBD Kg(Max)					
Kg / outer box							

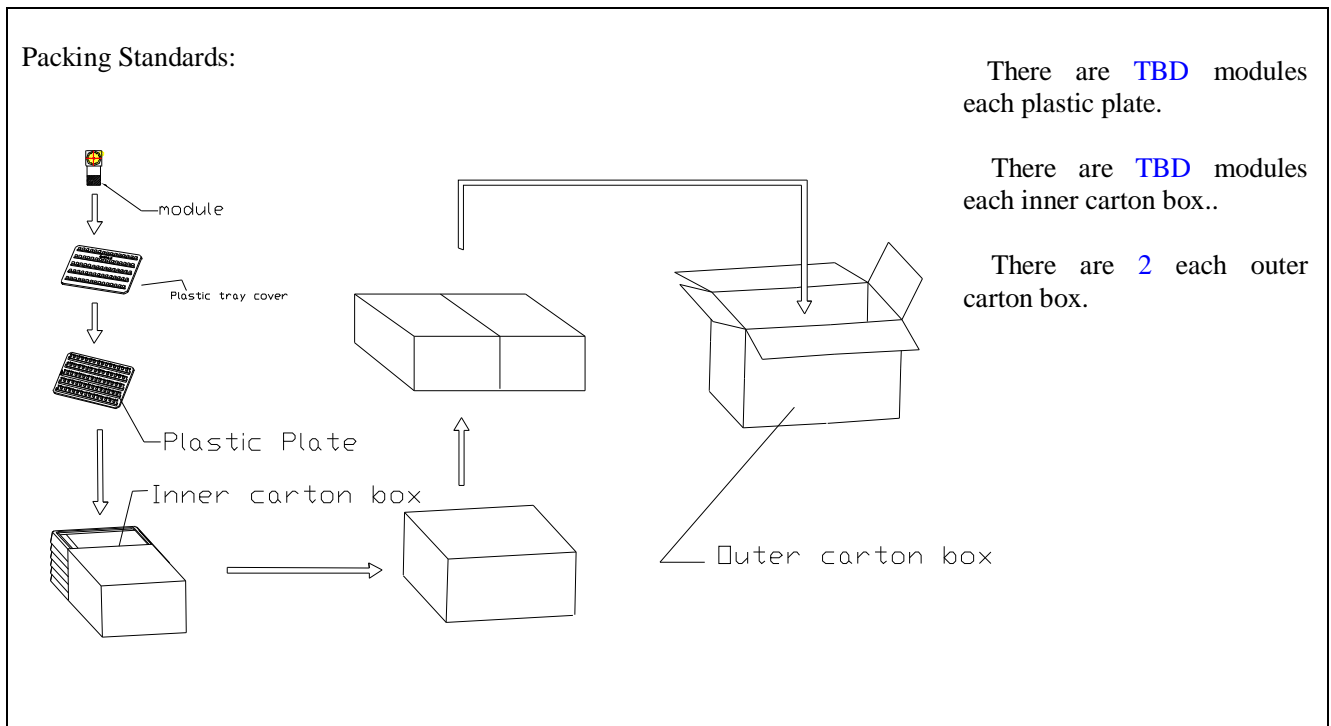

Requirements of outer carton box :

1. Weight(Max): **TBD** Kg
2. Height (Max): 0.17 M
3. Prohibition: Box made by log

Material for Plastic tray

It is made of antistatic polystyrene which has no chemical pollution. Surface resistivity : 10^6 ohm/sq

PRIOR CONSULT MATTER

- 1.①For Truly standard products, we keep the right to change material, process for improving the product property without notice on our customer.
②For OEM products, if any change needed which may affect the product property, we will consult with our customer in advance.
2. If you have special requirement about reliability condition, please let us know before you start the test on our samples.

FACTORY CONTACT INFORMATION

FACTORY NAME: TRULY OPTO-ELECTRONICS LTD.

FACTORY ADDRESS: Truly Industrial Area, ShanWei City, GuangDong, China

FACTORY PHONE: 86-0660-3380061 **FAX:** 86-0660-3371772