

SPECIFICATION

PART NO. : TOE9M0052-W-E

OLED
96X96

1.12"



This specification maybe changed without any notice in order to improve performance or quality etc.

Please contact TRULY Semiconductors LTD. OLED R&D department for update specification and product status before design for this product or release the order.

PRODUCT CONTENTS

- PHYSICAL DATA
- ABSOLUTE MAXIMUM RATINGS
- EXTERNAL DIMENSIONS
- ELECTRICAL CHARACTERISTICS
- TIMING OF POWER SUPPLY
- ELECTRO-OPTICAL CHARACTERISTICS
- INTERFACE PIN CONNECTIONS
- COMMAND TABLE
- INITIALIZATION CODE
- SCHEMATIC EXAMPLE
- RELIABILITY TESTS
- OUTGOING QUALITY CONTROL SPECIFICATION
- CAUTIONS IN USING OLED MODULE

TRULY®信利		Customer	
Written by	Hujiabin	Approved by	
Checked by	Zhangweicang		
Approved by	Sujunhai		

■ PHYSICAL DATA

No.	Items:	Specification:	Unit
1	Diagonal Size	1.12	Inch
2	Resolution	96 (H) x 96(V)	Lines
3	Active Area	20.04 (W) x 20.04(H)	mm
4	Outline Dimension (Panel)	28.8 (W) x 28.6(H)	mm
5	Pixel Pitch	0.209 (W) x 0.209 (H)	mm
6	Pixel Size	0.184 W) x 0.184(H)	mm
7	Driver IC	SSD1329Z	-
8	Display Color	White	-
9	Grayscale	4	Bit
10	Interface	Parallel / Serial	-
11	IC package type	COG	-
12	Thickness	1.5±0.1	mm
13	Weight	<2.6	g
14	Duty	1/96	-

■ ABSOLUTE MAXIMUM RATINGS

 Unless otherwise specified, $V_{SS} = 0V$

 ($T_a = 25^{\circ}C$)

Items		Symbol	Min	Typ.	Max	Unit
Supply Voltage	Logic	V_{DD}	-0.3	-	4.0	V
	I/O buffer	V_{DDIO}	-0.3	-	4.0	V
	Driving	V_{CC}	0	-	18.0	V
Operating Temperature		Top	-20	-	70	$^{\circ}C$
Storage Temperature		Tst	-30	-	80	$^{\circ}C$
Humidity		-	-	-	90	%RH

NOTE:

Permanent device damage may occur if **ABSOLUTE MAXIMUM RATINGS** are exceeded. Functional operation should be restricted to the conditions as detailed in the operational sections of this data sheet. Exposure to absolute maximum rating conditions for extended periods may affect reliability.

EXTERNAL DIMENSIONS

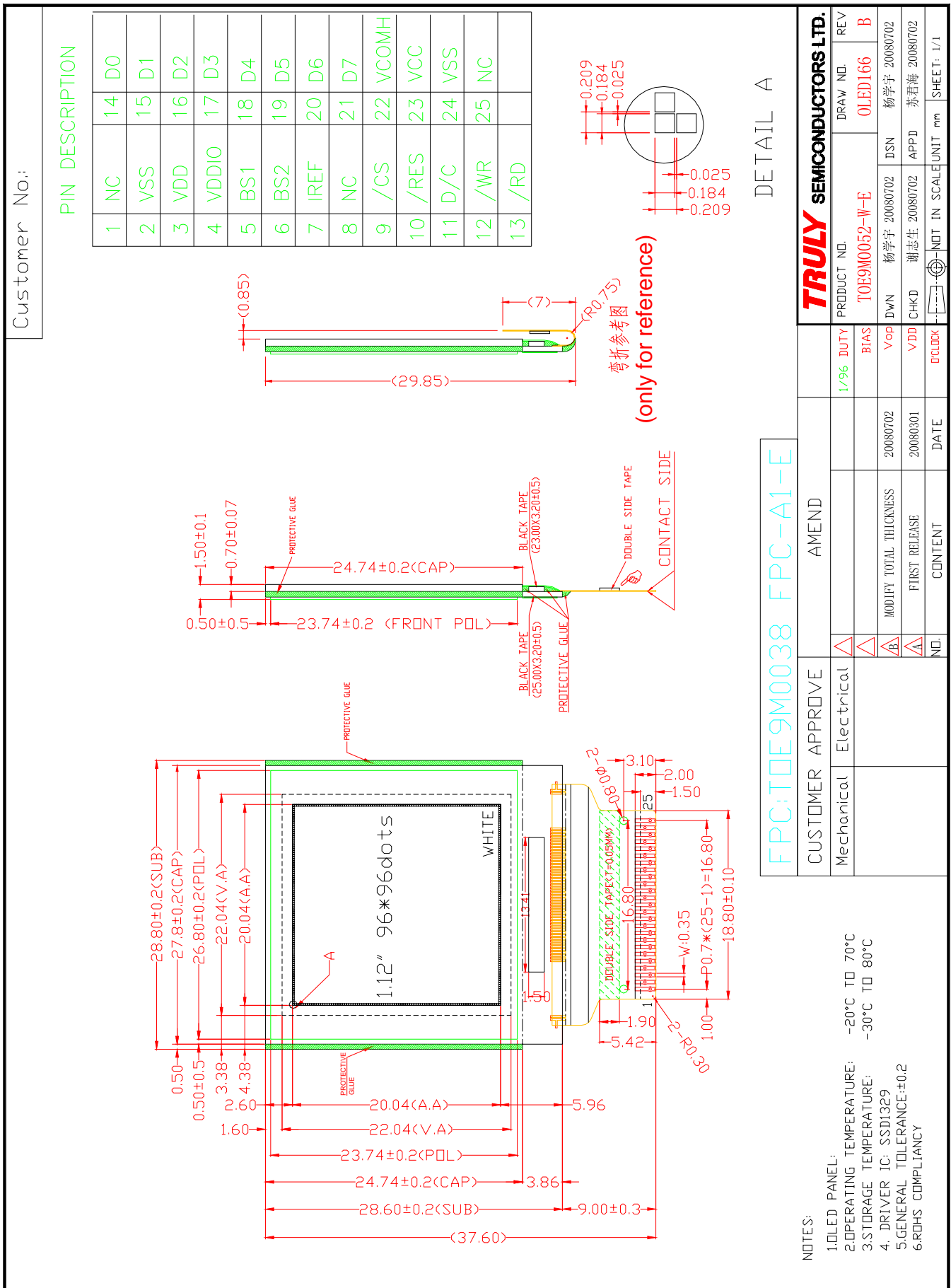

■ ELECTRICAL CHARACTERISTICS

◆ DC Characteristics

Unless otherwise specified, $V_{SS} = 0V$, $V_{DD} = 2.4V$ to $3.5V$ ($T_a = 25^\circ C$)

Items		Symbol	Min	Typ.	Max	Unit
Supply Voltage	Logic	V_{DD}	2.4	3.0	3.5	V
	I/O buffer	V_{DDIO}	1.7	3.0	V_{DD}	V
	Operating	V_{CC}	9.0	13.0	16.0	V
Input Voltage	High Voltage	V_{IH}	$0.8 \times V_{DD}$	-	V_{DD}	V
	Low Voltage	V_{IL}	V_{SS}	-	$0.2 \times V_{DD}$	V
Output Voltage	High Voltage	V_{OH}	$0.9 \times V_{DD}$	-	V_{DD}	V
	Low Voltage	V_{OL}	V_{SS}	-	$0.1 \times V_{DD}$	V

◆ AC Characteristics

Use 8080/6800-Series MPU Parallel Interface or Serial Interface

1:6800 Series MPU Parallel Interface

Conditions:

$$V_{DD} \sim V_{SS} = 2.4 \text{ to } 3.5\text{V}$$

$$T_A = 25^\circ\text{C}$$

6800-Series MPU Parallel Interface Timing Characteristics

Symbol	Parameter	Min	Typ	Max	Unit
t_{cycle}	Clock Cycle Time	300	-	-	ns
t_{AS}	Address Setup Time	0	-	-	ns
t_{AH}	Address Hold Time	0	-	-	ns
t_{DSW}	Write Data Setup Time	40	-	-	ns
t_{DHW}	Write Data Hold Time	15	-	-	ns
t_{DHR}	Read Data Hold Time	20	-	-	ns
t_{OH}	Output Disable Time	-	-	70	ns
t_{ACC}	Access Time	-	-	140	ns
PW_{CSL}	Chip Select Low Pulse Width (read)	120	-	-	ns
	Chip Select Low Pulse Width (write)	60	-	-	ns
PW_{CSH}	Chip Select High Pulse Width (read)	60	-	-	ns
	Chip Select High Pulse Width (write)	60	-	-	ns
t_R	Rise Time	-	-	15	ns
t_F	Fall Time	-	-	15	ns

6800-series MPU parallel interface characteristics

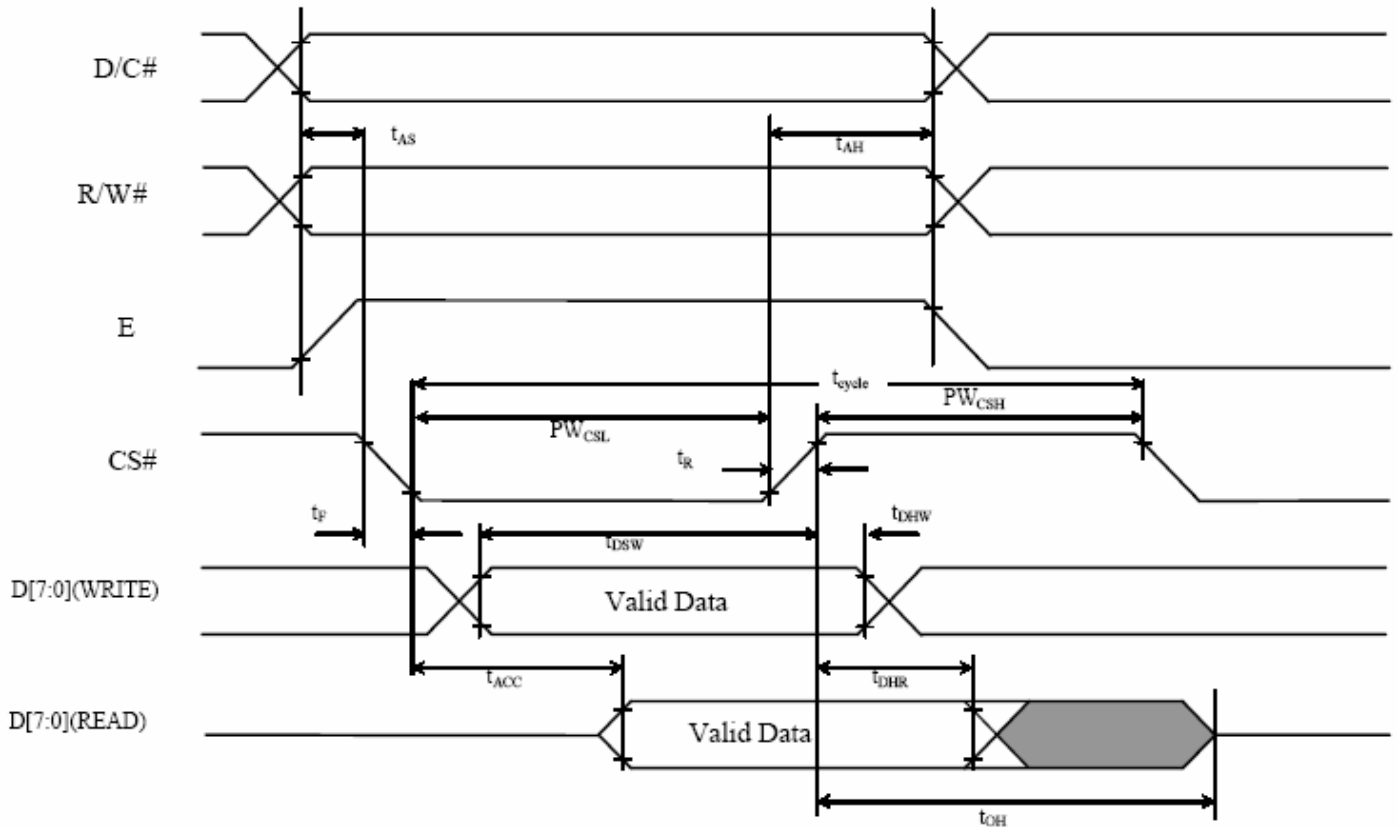

2:8080 Series MPU Parallel Interface

Conditions:

$V_{DD} \sim V_{SS} = 2.4 \text{ to } 3.5\text{V}$

$T_A = 25^\circ\text{C}$

8080-Series MPU Parallel Interface Timing Characteristics

Symbol	Parameter	Min	Typ	Max	Unit
t_{cycle}	Clock Cycle Time	300	-	-	ns
t_{AS}	Address Setup Time	0	-	-	ns
t_{AH}	Address Hold Time	0	-	-	ns
t_{DSW}	Write Data Setup Time	40	-	-	ns
t_{DHW}	Write Data Hold Time	15	-	-	ns
t_{DHR}	Read Data Hold Time	20	-	-	ns
t_{OH}	Output Disable Time	-	-	70	ns
t_{ACC}	Access Time	-	-	140	ns
PW_{CSL}	Chip Select Low Pulse Width (read)	120	-	-	ns
	Chip Select Low Pulse Width (write)	60	-	-	ns
PW_{CSH}	Chip Select High Pulse Width (read)	60	-	-	ns
	Chip Select High Pulse Width (write)	60	-	-	ns
t_R	Rise Time	-	-	15	ns
t_F	Fall Time	-	-	15	ns

8080-series MPU parallel interface characteristics

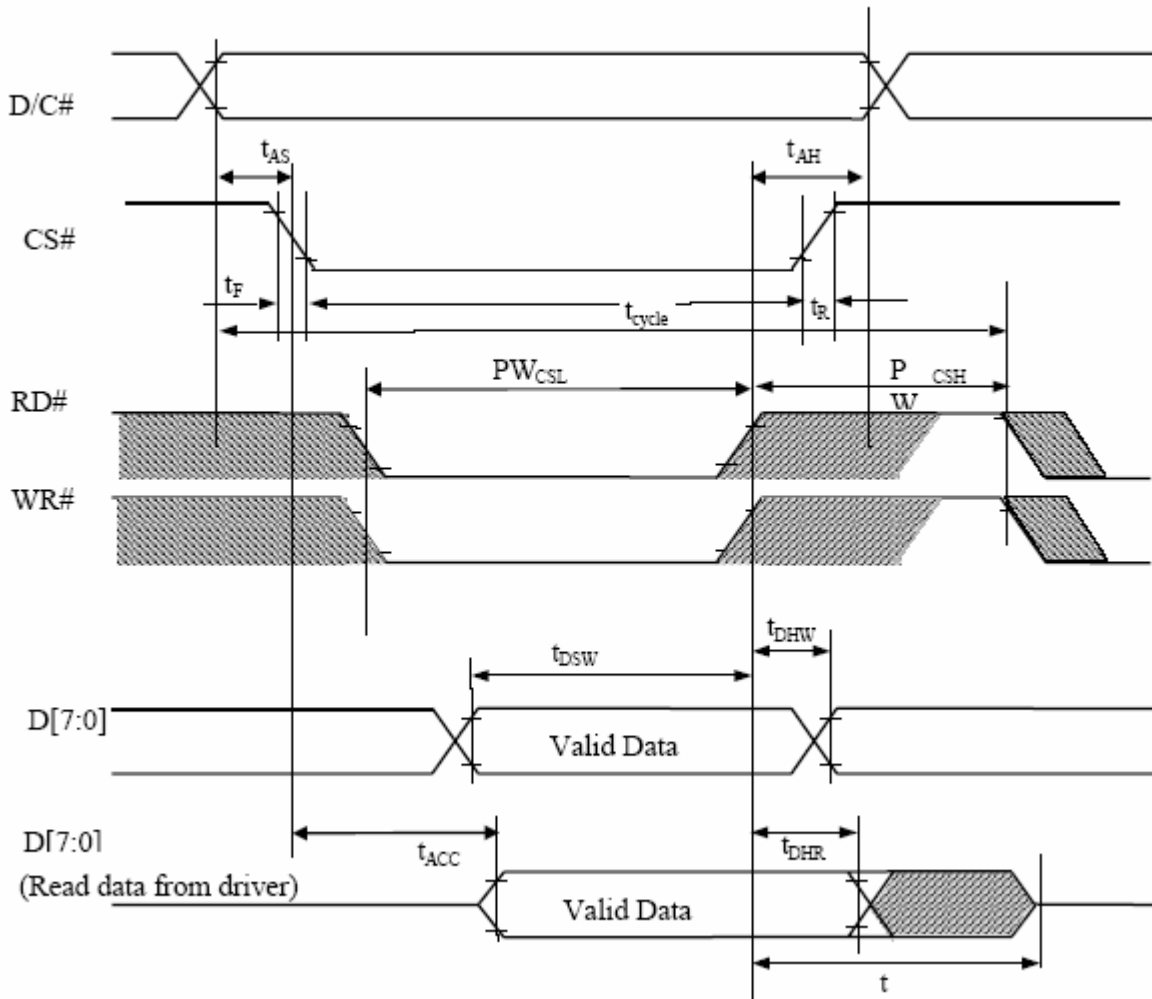

3:Serial Interface

Conditions:

$V_{DD} \sim V_{SS} = 2.4 \text{ to } 3.5\text{V}$

$T_A = 25^\circ\text{C}$

Serial Interface Timing Characteristics

Symbol	Parameter	Min	Typ	Max	Unit
t_{cycle}	Clock Cycle Time	250	-	-	ns
t_{AS}	Address Setup Time	150	-	-	ns
t_{AH}	Address Hold Time	150	-	-	ns
t_{CSS}	Chip Select Setup Time	120	-	-	ns
t_{CSH}	Chip Select Hold Time	60	-	-	ns
t_{DSW}	Write Data Setup Time	100	-	-	ns
t_{DHW}	Write Data Hold Time	100	-	-	ns
t_{CLKL}	Clock Low Time	100	-	-	ns
t_{CLKH}	Clock High Time	100	-	-	ns
t_R	Rise Time	-	-	15	ns
t_F	Fall Time	-	-	15	ns

Serial interface characteristics

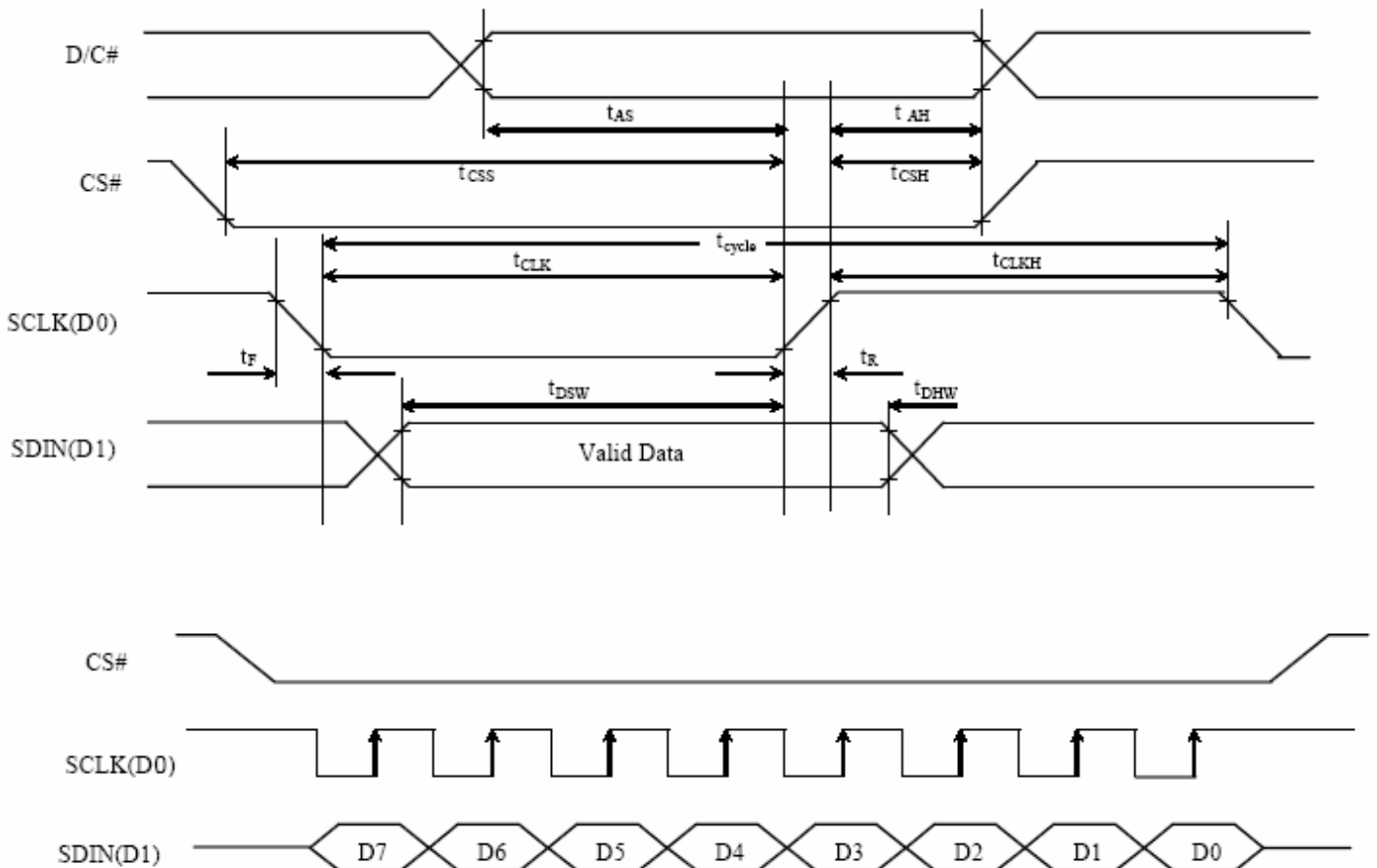

■ TIMING OF POWER SUPPLY

The following figures illustrate the recommended power ON and power OFF sequence of SSD1325.

Power ON sequence:

1. Power ON V_{DD} .
2. After V_{DD} become stable, set RES# pin LOW (logic LOW) for at least 3 μ s (t_1) and then HIGH (logic HIGH).
3. After set RES# pin LOW (logic LOW), wait for at least 3 μ s (t_2). Then Power ON V_{CC} .⁽¹⁾
4. After V_{CC} become stable, send command AFh for display ON. SEG/COM will be ON after 100ms (t_{AF}).

Figure 16 : The Power ON sequence

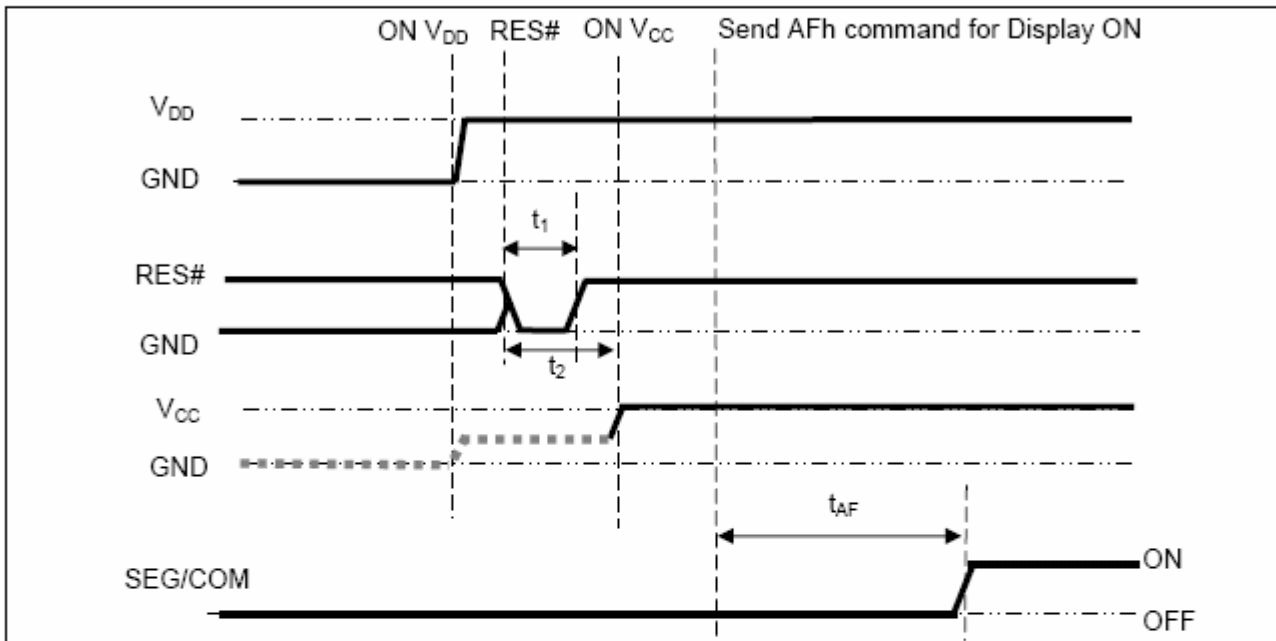

Power OFF sequence:

1. Send command AEh for display OFF.
2. Wait until panel discharges completely.
3. Power OFF V_{CC} .^{(1), (2)}
4. Wait for t_{OFF} . Power OFF V_{DD} . (where Minimum t_{OFF} =0ms, Typical t_{OFF} =100ms)

Figure 17 : The Power OFF sequence

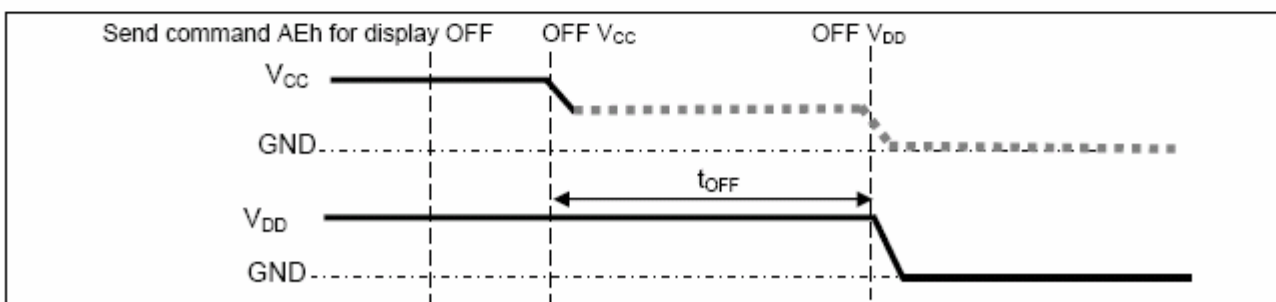

Note:

- ⁽¹⁾ Since an ESD protection circuit is connected between V_{DD} and V_{CC} , V_{CC} becomes lower than V_{DD} whenever V_{DD} is ON and V_{CC} is OFF as shown in the dotted line of V_{CC} in Figure 16 and Figure 17.
- ⁽²⁾ V_{CC} should be kept float when it is OFF.

■ **ELECTRO-OPTICAL CHARACTERISTICS (Ta=25°C)**

Items		Symbol	Min.	Typ.	Max.	Unit	Remark
Operating Luminance		L	50	60*	-	cd /m ²	White
Power Consumption		P	-	100	110	mW	30% pixels ON L=60cd/m ²
Frame Frequency		Fr	-	100	-	Hz	
Color Coordinate	White	CIE x	0.25	0.30	0.35	CIE1931	Darkroom
		CIE y	0.31	0.36	0.41		
Response Time	Rise	Tr	-	-	0.02	ms	-
	Decay	Td	-	-	0.02	ms	-
Contrast Ratio*		Cr	10000:1	-	-		Darkroom
Viewing Angle Uniformity		△ θ	160	-	-	Degree	-
Operating Life Time*		Top	80,000	-	-	Hours	L=60cd/m ²

Note:

1. **60cd/m²** is base on V_{DD}=3.0V, V_{PP}=13.0V, contrast command setting 0x7F;
2. **Contrast ratio** is defined as follows:

$$\text{Contrast ratio} = \frac{\text{Photo - detector output with OLED being "white"}}{\text{Photo - detector output with OLED being "black"}}$$

3. **Life Time** is defined when the Luminance has decayed to less than 50% of the initial Luminance specification. (30% pixels scrolling display on)
(The initial value should be closed to the typical value after adjusting.)

■ **INTERFACE PIN CONNECTIONS**

No	Symbol	Description
1	NC	No connection
2	V _{SS}	Ground
3	V _{DD}	Logic voltage supply for IC
4	V _{DDIO}	Power supply pin of I/O buffer
5	BS1	MCU bus interface selection pin
6	BS2	MCU bus interface selection pin
7	I _{REF}	This pin is the segment output current reference pin
8	NC	No connection
9	/CS	The chip select pin. Low is enabled
10	/RES	This pin is reset signal input
11	D/C	This pin is the Data/Command control pin,
12	/WR	MCU interface input pin
13	/RD	MCU interface input pin
14~21	D0~D7	These pins are 8-bit bi_directional Data bus
22	V _{COMH}	High level voltage output of COM signal
23	V _{CC}	High voltage supply for OLED panel
24	V _{SS}	Ground
25	NC	No connection

■ **COMMAND TABLE**

(D/C# = 0, R/W# (WR#) = 0, E (RD#) = 1) unless specific setting is stated

Fundamental Command Table										Command	Description
D/C#	Hex	D7	D6	D5	D4	D3	D2	D2	D0		
0	15	0	0	0	1	0	1	0	1	Set Column Address	Setup Column start and end address A[5:0]: Start Address, range:00h~3Fh, (POR = 00h) B[5:0]: End Address, range:00h~3Fh, (POR = 3Fh)
0	A[5:0]	*	*	A ₅	A ₄	A ₃	A ₂	A ₁	A ₀		Please refers to Section 8.10 Graphic Display Data RAM (GDDRAM) for relationship between Column Address setting and GDDRAM structure.
0	B[5:0]	*	*	B ₅	B ₄	B ₃	B ₂	B ₁	B ₀		
0	75	0	1	1	1	0	1	0	1	Set Row Address	Setup Row start and end address A[6:0]: Start Address, range:00h~7Fh, (POR = 00h) B[6:0]: End Address, range:00h~7Fh, (POR = 7Fh)
0	A[6:0]	*	A ₆	A ₅	A ₄	A ₃	A ₂	A ₁	A ₀		Please refers to 8.10 Graphic Display Data RAM (GDDRAM) for relationship between Row Address setting and GDDRAM structure.
0	B[6:0]	*	B ₆	B ₅	B ₄	B ₃	B ₂	B ₁	B ₀		
0	81	1	0	0	0	0	0	0	1	Set Contrast Current	A[7:0]: Set Contrast Value, range:0~ 255, (POR = 80h)
0	A[7:0]	A ₇	A ₆	A ₅	A ₄	A ₃	A ₂	A ₁	A ₀		
0	82	1	0	0	0	0	0	1	0	Set Second Pre-charge Speed	A[7:1]: Set Second Pre-charge Speed A[7:1] = 0000000b, Second Pre-charge speed = 1 A[7:1] = 0000001b, Second Pre-charge speed = 3 : A[7:1] = 1111111b, Second Pre-charge speed = 255 The RESET value of A[7:1] depends on the value of the contrast current (81h) and is equal to: 2*81h A[7:0] +1 (maximum 7Fh) A[0] = 0, Disable doubling the Second Pre-charge speed (POR) A[0] = 1, Enable doubling the Second Pre-charge speed Please refer to Figure 10-3 for the illustration of difference Second Pre-charge speed settings.
0	A[7:0]	A ₇	A ₆	A ₅	A ₄	A ₃	A ₂	A ₁	A ₀		
0	90	1	0	0	1	0	0	0	0	Set Master Icon Control	A[1:0]: Icon control A[1:0] = 00b, Icon RESET to normal display (POR) A[1:0] = 01b, Icon All ON (without altering icon ON / OFF register) A[1:0] = 10b, Icon All OFF (without altering icon ON/ OFF register) A[4] = 0b, Disable icon display (POR) A[4] = 1b, Enable icon display A[5] = 0b, Disable V _{ICON} charge pump circuit (POR) A[5] = 1b, Enable V _{ICON} charge pump circuit
0	A[7:0]	*	*	A ₅	A ₄	*	*	A ₁	A ₀		

Fundamental Command Table											
D/C#	Hex	D7	D6	D5	D4	D3	D2	D2	D0	Command	Description
0 0	91 A[7:0]	1 A ₇	0 A ₆	0 A ₅	1 A ₄	0 A ₃	0 A ₂	0 A ₁	1 A ₀	Set Icon Current Range	<p>A[7:0]: Set Icon current</p> <p>A[7:0] = 00h, max icon current = 0.0uA A[7:0] = 01h, max icon current = 0.5uA A[7:0] = 02h, max icon current = 1.0uA A[7:0] = 03h, max icon current = 1.5uA A[7:0] = 04h, max icon current = 2.0uA A[7:0] = FCh, max icon current = 126.0uA A[7:0] = FDh, max icon current = 126.5uA A[7:0] = FEh, max icon current = 127.0uA A[7:0] = FFh, max icon current = 127.5uA (POR)</p> <p>Note (1) The larger is the icon current range, the better the uniformity is.</p>
0 0 0 0 0	92 A0[6:0] A1[6:0] A62[6:0] A63[6:0]	1 * * * *	0 A ₀₆ A ₁₆ A ₆₂₆ A ₆₃₆	0 A ₀₅ A ₁₅ A ₆₂₅ A ₆₃₅	1 A ₀₄ A ₁₄ A ₆₂₄ A ₆₃₄	0 A ₀₃ A ₁₃ A ₆₂₃ A ₆₃₃	0 A ₀₂ A ₁₂ A ₆₂₂ A ₆₃₂	0 A ₀₁ A ₁₁ A ₆₂₁ A ₆₃₁	0 A ₀₀ A ₁₀ A ₆₂₀ A ₆₃₀	Set Individual Icon Current	<p>Set each Icon current by the formula: (AN[6:0] / 127) x max icon current, where the max icon current is defined by the command "Set icon current range" 91h and N=0~63.</p> <p>e.g. Icon Current of ICS0 = (A0[6:0]/127) x max icon current.</p> <p>A0[6:0] : icon current for ICS0, range: 00h~7Fh A1[6:0] : icon current for ICS1, range: 00h~7Fh A63[6:0] : icon current for ICS62, range: 00h~7Fh A64[6:0] : icon current for ICS63, range: 00h~7Fh</p> <p>Note (1) All 64 levels (1 level for each ICS signals) of icon current must be entered to operate this command properly. (2) The icon current of the unselected icon pins must be set to zero by this command.</p>
0 0	93 A[7:0]	1 A ₇	0 A ₆	0 A ₅	1 A ₄	0 A ₃	0 A ₂	1 A ₁	1 A ₀	Set Individual Icon ON / OFF Register	<p>Individual icon selection: A[5:0]: select one of the 64 icons from ICS0 ~ ICS63</p> <p>A[7:6] = 00b, turn OFF selected icon A[7:6] = 01b, turn ON selected icon A[7:6] = 11b, blink selected icon</p> <p>e.g. A[7:0] = 01000000b, turn ON icon ICS0 A[7:0] = 00111111b, turn OFF icon ICS63</p>
0 0	94 A[7:6]	1 A ₇	0 A ₆	0 *	1 *	0 *	1 *	0 *	0 *	Set Icon ON / OFF Registers	<p>A[7:6]: Icon register</p> <p>A[7:6] = 00b, turn OFF all icon A[7:6] = 01b, turn ON all icon A[7:6] = 11b, blink all icons</p>

Fundamental Command Table											
D/C#	Hex	D7	D6	D5	D4	D3	D2	D2	D0	Command	Description
0 0	95 A[7:0]	1 *	0 *	0 A ₅	1 A ₄	0 *	1 A ₂	0 A ₁	1 A ₀	Set Icon Blinking Cycle	<p>A[2:0]: Set Icon blinking cycle:</p> <p>000b 0.25sec</p> <p>001b 0.50sec</p> <p>010b 0.75sec</p> <p>011b 1.00sec (POR)</p> <p>100b 1.25sec</p> <p>101b 1.50sec</p> <p>110b 1.75sec</p> <p>111b 2.00sec</p> <p>A[5:4]: Set Icon oscillation frequency, frequency increase as level increases</p> <p>00b 61KHz</p> <p>01b 64KHz (POR)</p> <p>10b 68KHz</p> <p>11b 73KHz</p> <p>Note (1) Blinking cycles is measured at 100Hz icon frame frequency and duty ratio of 50%</p>
0 0	96 A[7:0]	1 A ₇	0 A ₆	0 A ₅	1 A ₄	0 *	1 A ₂	1 A ₁	0 A ₀	Set Icon Duty	<p>A[2:0]: Set icon AC drive</p> <p>000b DC drive (POR)</p> <p>001b 63 / 64 duty ratio</p> <p>010b 62 / 64 duty ratio</p> <p>011b 61 / 64 duty ratio</p> <p>100b 60 / 64 duty ratio</p> <p>101b 59 / 64 duty ratio</p> <p>110b 58 / 64 duty ratio</p> <p>111b 57 / 64 duty ratio</p> <p>A[7:4]: Set icon frame frequency</p> <p>Note (1) Icon frame frequency must NOT be set to 0000b</p>
0 0	A0 A[7:0]	1 A ₇	0 A ₆	1 A ₅	0 A ₄	0 A ₃	0 A ₂	0 A ₁	0 A ₀	Set Re-map	<p>Re-map setting in Graphic Display Data RAM (GDDRAM)</p> <p>A[7:0]: Remap (POR = 00h)</p> <p>A[0] = 0b, Disable Column Address Re-map (POR) A[0] = 1b, Enable Column Address Re-map</p> <p>A[1] = 0b, Disable Nibble Re-map (POR) A[1] = 1b, Enable Nibble Re-map</p> <p>A[2] = 0b, Enable Horizontal Address Increment (POR) A[2] = 1b, Enable Vertical Address Increment</p> <p>A[4] = 0b, Disable COM Re-map (POR) A[4] = 1b, Enable COM Re-map</p> <p>A[6] = 0b, Disable COM Split Odd Even (POR) A[6] = 1b, Enable COM Split Odd Even</p>

Fundamental Command Table											
D/C#	Hex	D7	D6	D5	D4	D3	D2	D2	D0	Command	Description
0 0	A1 A[7:0]	1 *	0 A ₆	1 A ₅	0 A ₄	0 A ₃	0 A ₂	0 A ₁	1 A ₀	Set Display Start Line	A[6:0]: Vertical scroll by setting the starting address of display RAM from 0 ~ 127 (POR = 00h)
0 0	A2 A[7:0]	1 *	0 A ₆	1 A ₅	0 A ₄	0 A ₃	0 A ₂	1 A ₁	0 A ₀	Set Display Offset	A[6:0]: Set vertical offset by COM from 0 ~ 127 (POR = 00h) e.g. Set A[6:0] to 010000b to move COM16 towards COM0 direction for 16 row
0 0 0 0	A4 A5 A6 A7	1 1 1 1	0 0 0 0	1 1 1 1	0 0 0 0	0 0 0 0	1 1 1 1	0 0 1 1	0 1 0 1	Set Display Mode	A4: Normal display (POR) A5: All ON (All pixels have gray scale of 15, GS15) A6: All OFF (All pixels have gray scale of 0, GS0) A7: Inverse Display (GS0 → GS15, GS1 → GS14, GS2 → GS13, ...)
0 0	A8 A[6:0]	0 *	0 A ₆	0 A ₅	1 A ₄	0 A ₃	1 A ₂	0 A ₁	1 A ₀	Set MUX Ratio	A[6:0]: Set MUX ratio from 16MUX ~ 128MUX: A[6:0] = 15 represents 16MUX A[6:0] = 16 represents 17MUX : A[6:0] = 126 represents 127MUX A[6:0] = 127 represents 128MUX (POR) It should be noted that A[6:0]=0~14 is not allowed.
0 0	AE AF	1 1	0 0	1 1	0 0	1 1	1 1	1 1	0 1	Set Sleep mode ON / OFF	A[0] = 0b, Sleep mode ON (The display is OFF) A[0] = 1b, Sleep mode OFF (The display is ON)
0 0	B1 A[7:0]	1 A ₇	0 A ₆	1 A ₅	1 A ₄	0 A ₃	0 A ₂	0 A ₁	1 A ₀	Set Phase Length	A[7:0]: RESET and first pre-charge phase length (POR=53h) A[3:0]: Phase 1 period of 1~16 DCLK's (POR=3h) e.g. A[3:0] = 1111b, 16 DCLK Clock A[7:4]: Phase 2 period of 1~16 DCLK's (POR=5h) e.g. A[7:4] = 1111b, 16 DCLK Clocks
0 0	B2 A[6:0]	1 *	0 A ₆	1 A ₅	1 A ₄	0 A ₃	0 A ₂	1 A ₁	0 A ₀	Set Frame Frequency	Set the frame frequency of the matrix display A[6:0]: Total number of DCLK's per row. Ranging from 14h to 4Eh DCLK's (POR = 23h) Then the frame Frequency = DCLK freq /A[6:0].

Fundamental Command Table											
D/C#	Hex	D7	D6	D5	D4	D3	D2	D2	D0	Command	Description
0 0	B3 A[7:0]	1 A ₇	0 A ₆	1 A ₅	1 A ₄	0 A ₃	0 A ₂	1 A ₁	1 A ₀	Set Front Clock Divider /Oscillator Frequency	A[3:0]: Define divide ratio (D) of display clock (DCLK) Divide ratio=A[3:0]+1 (POR is 0000b, i.e. divide ratio = 1) A[7:4]: Set the Oscillator Frequency, F _{osc} . Oscillator Frequency increases with the value of A[7:4] and vice versa. Range:0h~Fh (POR= 0h represents 500KHz, typical step value: 4% of previous value)
0	B7	1	0	1	1	0	1	1	1	Set Default Gray Scale Table	The default gray scale table is set in unit of DCLKs as follow: GS1 level Pulse width = 2 DCLKs GS2 level Pulse width = 4 DCLKs GS3 level Pulse width = 6 DCLKs GS13 level Pulse width = 26 DCLKs GS14 level Pulse width = 28 DCLKs GS15 level Pulse width = 30 DCLKs
0 0 0 0 0	B8 A1[5:0] A2[5:0] A14[5:0] A15[5:0]	1 * * * *	0 * * * *	1 A ₁₅ A ₂₅ A ₁₄₅ A ₁₅₅	1 A ₁₄ A ₂₄ A ₁₄₄ A ₁₅₄	1 A ₁₃ A ₂₃ A ₁₄₃ A ₁₅₃	0 A ₁₂ A ₂₂ A ₁₄₂ A ₁₅₂	0 A ₁₁ A ₂₁ A ₁₄₁ A ₁₅₁	0 A ₁₀ A ₂₀ A ₁₄₀ A ₁₅₀	Look Up Table for Gray Scale Pulse width	Set gray scale (GS1~GS15) pulse width in unit of DCLKs. A1[5:0], value for GS1 level Pulse width A2[5:0], value for GS2 level Pulse width A14[5:0], value for GS14 level Pulse width A15[5:0], value for GS15 level Pulse width Note (1) The pulse width value of GS1, GS2, ..., GS15 should not be equal. i.e. 0<GS1<GS2 ... <GS15
0 0	BB A[3:0]	1 *	0 *	1 *	1 *	1 A ₃	0 A ₂	1 A ₁	1 A ₀	Set Second Pre-charge Period	A[3:0]: Set Second pre-charge period 0000b 0 DCLK 0001b 1 DCLKs 0010b 2 DCLKs : 0111b 7 DCLKs (POR) : 1111b 15 DCLKs

Fundamental Command Table											
D/C#	Hex	D7	D6	D5	D4	D3	D2	D2	D0	Command	Description
0 0	BC A[5:0]	1 *	0 *	1 A ₅	1 A ₄	1 A ₃	1 A ₂	1 A ₁	0 A ₀		A[5:0]: Set First Pre-charge voltage 000000b 0.30 x V _{CC} 000001b 0.31 x V _{CC} 001111b 0.45 x V _{CC} (POR) 011111b 0.63 x V _{CC} 1xxxxxb 1.00 x V _{CC} or connect to V _{COMH} if V _{CC} > V _{COMH}
0 0	BE A[6:0]	1 *	0 A ₆	1 A ₅	1 A ₄	1 A ₃	1 A ₂	1 A ₁	0 A ₀		A[6:0] : Output level high voltage for COM signal 000000b 0.51 x V _{CC} 000001b 0.52 x V _{CC} 011110b 0.82 x V _{CC} 011111b 0.84 x V _{CC} (POR)
0	E3	1	1	1	0	0	0	1	1	NOP	Command for No Operation
0 0	FD A[2]	1 0	1 0	1 0	1 1	1 0	1 A ₂	0 1	1 0		A[2]: MCU protection status (POR = 12h) A[2] = 0h, disable locking the MCU from entering command (POR) A[2] = 1h, enable locking the MCU from entering command Note (1) Locking prohibits all commands and memory access.

Note

(1) "*" stands for "Don't care".

(2) POR stands for Power On Reset.

■ INITIALIZATION CODE

```
Void init_oled()
{
    W_COMMAND(0x15); //SET COLUMN ADDR
    W_COMMAND(0x00);
    W_COMMAND(0x2f);
    W_COMMAND(0x75); //SET ROW ADDR
    W_COMMAND(0x00);
    W_COMMAND(0x5f);

    W_COMMAND(0xA0); //SET RE-MAP
    W_COMMAND(0x42);
    W_COMMAND(0xA1); //SET DISPLAY START LINE
    W_COMMAND(0x00);
    W_COMMAND(0xA2); //SET DISPLAY OFFSET
    W_COMMAND(0x00);
    W_COMMAND(0xA4); //SET DISPLAY MODE
    W_COMMAND(0xA8); //SET MUX RADIO
    W_COMMAND(0x5F);
    W_COMMAND(0xB2); //SET FRAME FREQUENCY
    W_COMMAND(0x23);
    W_COMMAND(0xB3); //SET FRONT CLOCK DIVIDER & OSCILLATOR FREQUENCY
    W_COMMAND(0xF0);

    W_COMMAND(0x81); //SET CONTRAST CURRENT
    W_COMMAND(0x7F); //
    W_COMMAND(0xBC); //first pre_charge voltage
    W_COMMAND(0x1F);

    W_COMMAND(0x82); //second pre_charge speed
    W_COMMAND(0xFE);

    W_COMMAND(0xB1); //first pre_charge phase length
    W_COMMAND(0x21);

    W_COMMAND(0xBB); //SET SECONDE PRE_CHARGE PERIOD
    W_COMMAND(0x0F);

    W_COMMAND(0xbe); //SET VCOMH
    W_COMMAND(0x1F);

    W_COMMAND(0xB8); //SET GS
    W_COMMAND(0x04); //GS1
    W_COMMAND(0x06); //GS2
    W_COMMAND(0x08); //GS3
    W_COMMAND(0x0B); //GS4
    W_COMMAND(0x0E); //GS5
    W_COMMAND(0x11); //GS6
    W_COMMAND(0x15); //GS7
    W_COMMAND(0x19); //GS8
    W_COMMAND(0x1D); //GS9
    W_COMMAND(0x22); //GS10
```

```
W_COMMAND(0x27); //GS11  
W_COMMAND(0x2C); //GS12  
W_COMMAND(0x32); //GS13  
W_COMMAND(0x38); //GS14  
W_COMMAND(0x3F); //GS15
```

```
W_COMMAND(0xAF); //DSPLAY ON  
}
```

■ SCHEMATIC EXAMPLE

◆ 8080 Series Interface Application Circuit(External $V_{CC}=13.0V$):

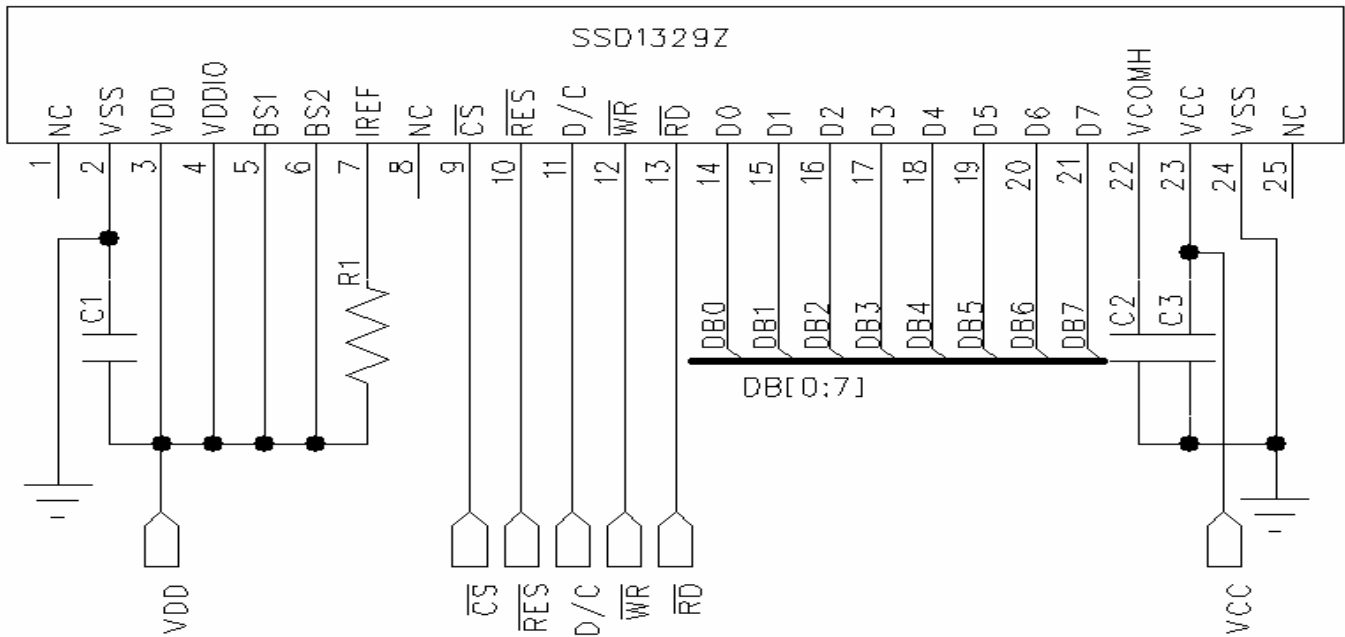

◆ Serial Interface Application Circuit(External $V_{CC}=13.0V$):

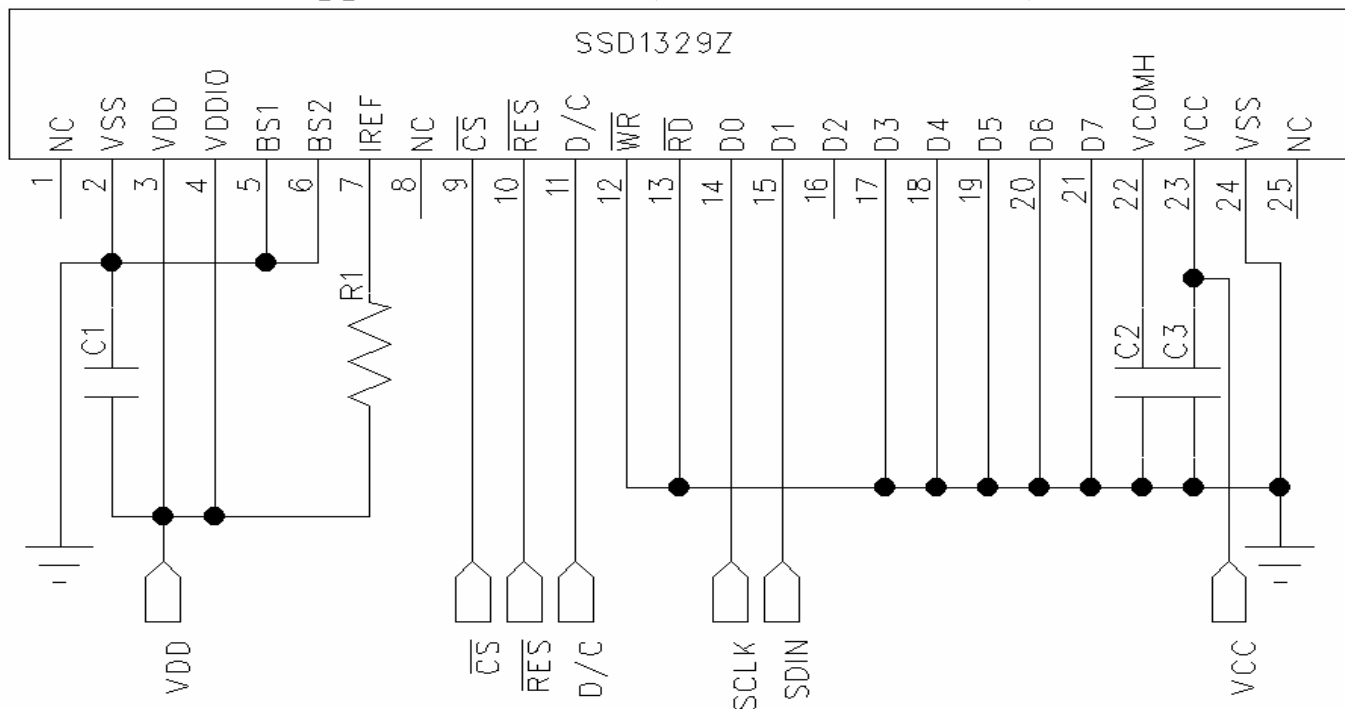

NOTE:

1. $R1=200K\Omega, C1=C2=C3=4.7\mu F$;

2.The V_{CC} should connect a external voltage;

3.In Serial interface mode , only write operations are allowed, and during data writing ,an additional NOP command should be inserted before the CS# goes HIGH .

■ **RELIABILITY TESTS**

Item		Condition	Criterion
High Temperature Storage (HTS)		80±2°C , 200 hours	1. After testing, the function test is ok. 2. After testing, no addition to the defect. 3. After testing, the change of luminance should be within +/- 50% of initial value. 4. After testing, the change for the mono and area color must be within (+/-0.02, +/- 0.02) and for the full color it must be within (+/-0.04, +/-0.04) of initial value based on 1931 CIE coordinates. 5. After testing, the change of total current consumption should be within +/- 50% of initial value.
High Temperature Operating (HTO)		70±2°C , 96 hours	
Low Temperature Storage (LTS)		-30±2°C , 200 hours	
Low Temperature Operating (LTO)		-20±2°C , 96 hours	
High Temperature / High Humidity Storage (HTHHS)		50±3°C , 90%±3%RH, 120 hours	
Thermal Shock (Non-operation) (TS)		-20±2°C ~ 25°C ~ 70±2°C (30min) (5min) (30min) 10cycles	
Vibration (Packing)	10~55~10Hz, amplitude 1.5mm, 1 hour for each direction x, y, z	1. One box for each test. 2. No addition to the cosmetic and the electrical defects.	
Drop (Packing)	Height : 1 m, each time for 6 sides, 3 edges, 1 angle		
ESD (finished product housing)	±4kV (R: 330Ω C: 150pF , 10times, air discharge)	1. After testing, cosmetic and electrical defects should not happen. 2. In case of malfunction or defect caused by ESD damage, it would be judged as a good part if it would be recovered to normal state after resetting.	

Note: 1) For each reliability test, the sample quantity is 3, and only for one test item.

2) The HTHHS test is requested the Pure Water(Resistance>10MΩ).

3) The test should be done after 2 hours of recovery time in normal environment.

■OUTGOING QUALITY CONTROL SPECIFICATION

◆Standard

According to GB/T2828.1-2003/ISO 2859-1: 1999 and ANSI/ASQC Z1.4-1993, General Inspection Level II.

◆Definition

- 1 Major defect : The defect that greatly affect the usability of product.
- 2 Minor defect : The other defects, such as cosmetic defects, etc.
- 3 Definition of inspection zone:

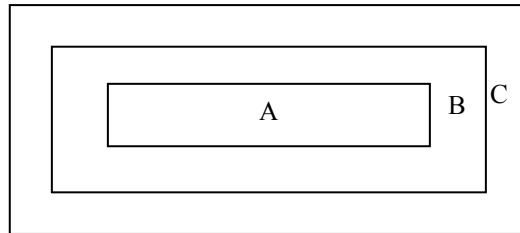

Zone A: Active Area

Zone B: Viewing Area except Zone A

Zone C: Outside Viewing Area

Note: As a general rule, visual defects in Zone C are permissible, when it is no trouble of quality and assembly to customer`s product.

◆Inspection Methods

- 1 The general inspection : under 20W x 2 or 40W fluorescent light, about 30cm viewing distance, within 45° viewing angle, under 25±5°C.

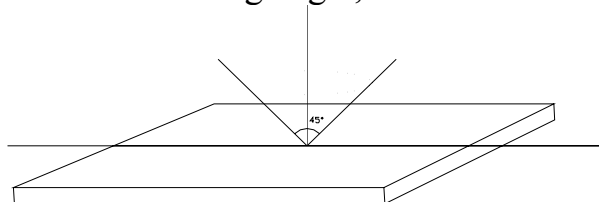

- 2 The luminance and color coordinate inspection : By PR705 or BM-7 or the equal equipments, in the dark room, under 25±5°C.

◆Inspection Criteria

- 1 Major defect : AQL= 0.65

Item	Criterion
Function Defect	1. No display or abnormal display is not accepted
	2. Open or short is not accepted.
	3. Power consumption exceeding the spec is not accepted.
Outline Dimension	Outline dimension exceeding the spec is not accepted.
Glass Crack	Glass crack tends to enlarge is not accepted.

- 2 Minor Defect : AQL= 1.5

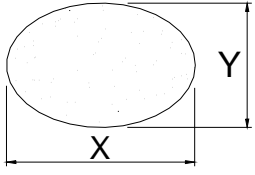
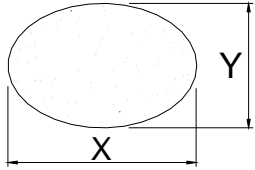
Item	Criterion			
Spot Defect (dimming and lighting spot)	Size (mm)		Accepted Qty	
			Area A + Area B	Area C
		$\Phi \leq 0.10$	Ignored	
		$0.10 < \Phi \leq 0.15$	3	Ignored
		$0.15 < \Phi \leq 0.20$	1	
$0.20 < \Phi$		0		
Note : $\Phi = (x + y) / 2$				
Line Defect (dimming and lighting line)	L (Length) : mm	W (Width) : mm	Area A + Area B	Area C
	/	$W \leq 0.03$	Ignored	
	$L \leq 3.0$	$0.03 < W \leq 0.05$	2	Ignored
	$L \leq 2.0$	$0.05 < W \leq 0.08$	1	
	/	$0.08 < W$	As spot defect	
Remarks: The total of spot defect and line defect shall not exceed 4 pcs.				
Polarizer Stain	Stain which can be wiped off lightly with a soft cloth or similar cleaning is accepted, otherwise, according to the Spot Defect and the Line Defect.			
Polarizer Scratch	1. If scratch can be seen during operation, according to the criterions of the Spot Defect and the Line Defect.			
	2. If scratch can be seen only under non-operation or some special angle, the criterion is as below :			
	L (Length) : mm	W (Width) : mm	Area A + Area B	Area C
	/	$W \leq 0.03$	Ignore	
	$5.0 < L \leq 10.0$	$0.03 < W \leq 0.05$	2	Ignore
	$L \leq 5.0$	$0.05 < W \leq 0.08$	1	
/	$0.08 < W$	0		
Polarizer Air Bubble	Size		Area A + Area B	Area C
		$\Phi \leq 0.20$	Ignored	
		$0.20 < \Phi \leq 0.50$	2	Ignored
		$0.50 < \Phi \leq 0.80$	1	
		$0.80 < \Phi$	0	

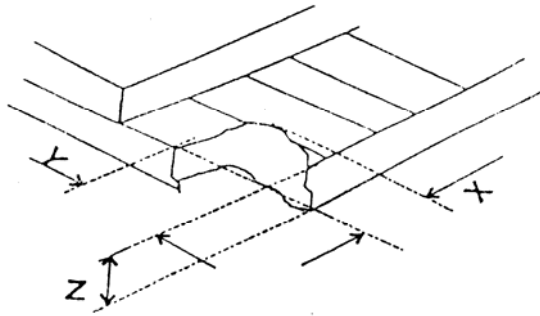
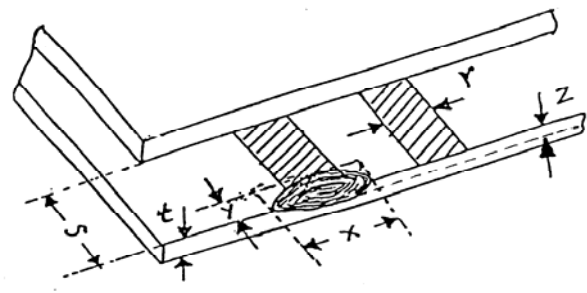
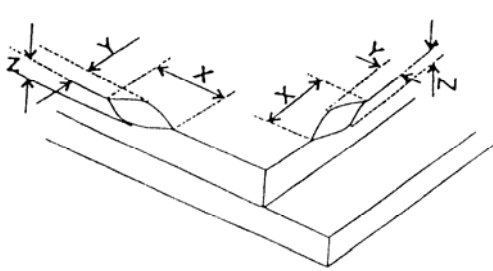
Glass Defect (Glass Chipped)	<p>1. On the corner</p>  <p style="text-align: right;">(mm)</p> <table border="1" style="margin-left: auto;"> <tr> <td>x</td> <td>≤ 2.0</td> </tr> <tr> <td>y</td> <td>$\leq S$</td> </tr> <tr> <td>z</td> <td>$\leq t$</td> </tr> </table>	x	≤ 2.0	y	$\leq S$	z	$\leq t$
	x	≤ 2.0					
	y	$\leq S$					
	z	$\leq t$					
<p>2. On the bonding edge</p>  <p style="text-align: right;">(mm)</p> <table border="1" style="margin-left: auto;"> <tr> <td>x</td> <td>$\leq a / 2$</td> </tr> <tr> <td>y</td> <td>$\leq s / 3$</td> </tr> <tr> <td>z</td> <td>$\leq t$</td> </tr> </table>	x	$\leq a / 2$	y	$\leq s / 3$	z	$\leq t$	
x	$\leq a / 2$						
y	$\leq s / 3$						
z	$\leq t$						
<p>3. On the other edges</p>  <p style="text-align: right;">(mm)</p> <table border="1" style="margin-left: auto;"> <tr> <td>x</td> <td>$\leq a / 5$</td> </tr> <tr> <td>y</td> <td>≤ 1.0</td> </tr> <tr> <td>z</td> <td>$\leq t$</td> </tr> </table>	x	$\leq a / 5$	y	≤ 1.0	z	$\leq t$	
x	$\leq a / 5$						
y	≤ 1.0						
z	$\leq t$						
<p>Note: t: glass thickness ; s: pad width ; a: the length of the edge</p>							
TCP Defect	Crack, deep fold and deep pressure mark on the TCP are not accepted						
Pixel Size	The tolerance of display pixel dimension should be within $\pm 20\%$ of the spec						
Luminance	Refer to the spec or the reference sample						
Color	Refer to the spec or the reference sample						

■ CAUTIONS IN USING OLED MODULE**◆ Precautions For Handling OLED Module:**

1. OLED module consists of glass and polarizer. Pay attention to the following items when handling:
 - i. Avoid drop from high, avoid excessive impact and pressure.
 - ii. Do not touch, push or rub the exposed polarizers with anything harder than an HB pencil lead.
 - iii. If the surface becomes dirty, breathe on the surface and gently wipe it off with a soft dry cloth. If it is terrible dirty, moisten the soft cloth with Isopropyl alcohol or Ethyl alcohol. Other solvents may damage the polarizer. Especially water, Ketone and Aromatic solvents.
 - iv. Wipe off saliva or water drops immediately, contact the polarizer with water over a long period of time may cause deformation.
 - v. Please keep the temperature within specified range for use and storage. Polarization degradation, bubble generation or polarizer peeling-off may occur with high temperature and high humidity.
 - vi. Condensation on the surface and the terminals due to cold or anything will damage, stain or dirty the polarizer, so make it clean as the way of iii.
2. Do not attempt to disassemble or process the OLED Module.
3. Make sure the TCP or the FPC of the Module is free of twisting, warping and distortion, do not pull or bend them forcefully, especially the soldering pins. On the other side, the SLIT part of the TCP is made to bend in the necessary case.
4. When assembling the module into other equipment, give the glass enough space to avoid excessive pressure on the glass, especially the glass cover which is much more fragile.
5. Be sure to keep the air pressure under 120 kPa, otherwise the glass cover is to be cracked.
6. Be careful to prevent damage by static electricity:
 - i. Be sure to ground the body when handling the OLED Modules.
 - ii. All machines and tools required for assembling, such as soldering irons, must be properly grounded.
 - iii. Do not assemble and do no other work under dry conditions to reduce the amount of static electricity generated. A relative humidity of 50%-60% is recommended.
 - iv. Peel off the protective film slowly to avoid the amount of static electricity generated.
 - v. Avoid to touch the circuit, the soldering pins and the IC on the Module by the body.
 - vi. Be sure to use anti-static package.
7. Contamination on terminals can cause an electrochemical reaction and corrode the terminal circuit, so make it clean anytime.
8. All terminals should be open, do not attach any conductor or semiconductor on the terminals.
9. When the logic circuit power is off, do not apply the input signals.
10. Power on sequence: $V_{DD} \rightarrow V_{CC}$, and power off sequence: $V_{CC} \rightarrow V_{DD}$.
11. Be sure to keep temperature, humidity and voltage within the ranges of the spec, otherwise shorten Module's life time, even make it damaged.
12. Be sure to drive the OLED Module following the Specification and datasheet of IC controller, otherwise something wrong may be seen.

13. When displaying images, keep them rolling, and avoid one fixed image displaying more than 30 seconds, otherwise the residue image is to be seen. This is the speciality of OLED.

◆ **Precautions For Soldering OLED Module:**

1. Soldering temperature : $260^{\circ}\text{C} \pm 10^{\circ}\text{C}$.
2. Soldering time : 3-4 sec.
3. Repeating time : no more than 3 times.
4. If soldering flux is used, be sure to remove any remaining flux after finishing soldering operation. (This does not apply in the case of a non-halogen type of flux.) It is recommended to protect the surface with a cover during soldering to prevent any damage due to flux spatters.

◆ **Precautions For Storing OLED Module:**

1. Be sure to store the OLED Module in the vacuum bag with dessicant.
2. If the Module can not be used up in 1 month after the bag being opened, make sure to seal the Module in the vacuum bag with dessicant again.
3. Store the Module in a dark place, do not expose to sunlight or fluorescent light.
4. The polarizer surface should not touch any other objects. It is recommended to store the Module in the shipping container.
5. It is recommended to keep the temperature between 0°C and 30°C , the relative humidity not over 60%.

◆ **Limited Warranty**

Unless relevant quality agreements signed with customer and law enforcement, for a period of 12 months from date of production, all products (except automotive products) TRULY will replace or repair any of its OLED modules which are found to be functional defect when inspected in accordance with TRULY OLED acceptance standards (copies available upon request). Cosmetic/visual defects must be returned to TRULY within 90 days of shipment. Confirmation of such date should be based on freight documents. The warranty liability of TRULY is limited to repair and/or replacement on the terms above. TRULY will not be responsible for any subsequent or consequential events.

◆ **Return OLED Module Under Warranty:**

1. No warranty in the case that the precautions are disregarded.
2. Module repairs will be invoiced to the customer upon mutual agreement. Modules must be returned with sufficient description of the failures or defects.

◆ **PRIOR CONSULT MATTER**

1. For TRULY standard products ,we keep the right to change material ,process ... for improving the product property without any notice on our customer.
2. If you have special requirement about reliability condition, please let us know before you start the test on our samples.