

SPECIFICATION

PART NO. : TOD9M0053-Y-E

OLED
128X64

1.6"



This specification maybe changed without any notice in order to improve performance or quality etc.

Please contact TRULY Semiconductors LTD. OLED R&D department for update specification and product status before design for this product or release the order.

PRODUCT CONTENTS

- PHYSICAL DATA
- ABSOLUTE MAXIMUM RATINGS
- EXTERNAL DIMENSIONS
- ELECTRICAL CHARACTERISTICS
- TIMING OF POWER SUPPLY
- ELECTRO-OPTICAL CHARACTERISTICS
- INTERFACE PIN CONNECTIONS
- COMMAND TABLE
- INTIALIZATION CODE
- SCHEMATIC EXAMPLE
- RELIABILITY TESTS
- OUTGOING QUALITY CONTROL SPECIFICATION
- CAUTIONS IN USING OLED MODULE

TRULY®信利		Customer	
Written by	Hujiabin	Approved by	
Checked by	Zhangweicang		
Approved by	Sujunhai		

■ PHYSICAL DATA

No.	Items:	Specification:	Unit
1	Diagonal Size	1.6	Inch
2	Resolution	128(H) x 64(V)	Lines
3	Active Area	36.45 (W) x 18.21(H)	mm
4	Outline Dimension (Panel)	46.83 (W) x 28.77(H)	mm
5	Pixel Pitch	0.285 (W) x 0.285 (H)	mm
6	Pixel Size	0.255 W) x 0.255(H)	mm
7	Driver IC	SSD1325T6R1	-
8	Display Color	Yellow	-
9	Grayscale	4	Bit
10	Interface	Parallel / Serial	-
11	IC package type	TCP	-
12	Thickness	2.1±0.1	mm
13	Weight	<6.2	g
14	Duty	1/64	-

■ ABSOLUTE MAXIMUM RATINGS

 Unless otherwise specified, $V_{SS} = 0V$

 ($T_a = 25^{\circ}C$)

Items		Symbol	Min	Typ.	Max	Unit
Supply Voltage	Logic	V_{DD}	-0.3	-	4.0	V
	Driving	V_{CC}	0	-	17.0	V
Operating Temperature		T_{op}	-20	-	70	$^{\circ}C$
Storage Temperature		T_{st}	-30	-	80	$^{\circ}C$
Humidity		-	-	-	90	%RH

NOTE:

Permanent device damage may occur if **ABSOLUTE MAXIMUM RATINGS** are exceeded. Functional operation should be restricted to the conditions as detailed in the operational sections of this data sheet. Exposure to absolute maximum rating conditions for extended periods may affect reliability.

EXTERNAL DIMENSIONS

Customer No.:

TRULY SEMICONDUCTORS LTD.

PRODUCT NO.	DRAW NO.	REV
TOP9M0053-Y-E	OLED154	B
DWN	DSN	
杨学宇 20080315	杨学宇 20080315	
CHKD	APPD	
谢志生 20080315	苏君海 20080315	
UNIT	SCALE	UNIT
mm		mm
NOT IN SCALE		SHEET: 1/1

PIN DESCRIPTION

1	NC	17	CS#
2	VCC	18	NC
3	VCOMH	19	BS2
4	IREF	20	BS1
5	D7	21	VDD
6	D6	22	NC
7	D5	23	NC
8	D4	24	NC
9	D3	25	VBREF
10	D2	26	RESE
11	D1	27	FB
12	D0	28	VDDDB
13	E/RD#	29	GDR
14	R/W#	30	VSS
15	D/C#	31	VSL
16	RES#		

弯折参考图

NOTES:

1. OLED PANEL:
2. OPERATING TEMPERATURE: -20°C TO 70°C
3. STORAGE TEMPERATURE: -30°C TO 80°C
4. DRIVER IC: SSD1325T6R1
5. GENERAL TOLERANCE: ±0.2
6. ROHS COMPLIANT

CUSTOMER APPROVE	AMEND	DATE	CONTENT
Mechanical		20071122	FIRST RELEASE
Electrical			

■ **ELECTRICAL CHARACTERISTICS**

◆ **DC Characteristics**

Unless otherwise specified, $V_{SS} = 0V$, $V_{DD} = 2.4V$ to $3.5V$ ($T_a = 25^\circ C$)

Items		Symbol	Min	Typ.	Max	Unit
Supply Voltage	Logic	V_{DD}	2.4	3.0	3.5	V
	Operating	V_{CC}	8.0	12.0	16.0	V
Input Voltage	High Voltage	V_{IH}	$0.8 \times V_{DD}$	-	V_{DD}	V
	Low Voltage	V_{IL}	V_{SS}	-	$0.2 \times V_{DD}$	V
Output Voltage	High Voltage	V_{OH}	$0.9 \times V_{DD}$	-	V_{DD}	V
	Low Voltage	V_{OL}	V_{SS}	-	$0.1 \times V_{DD}$	V

◆ AC Characteristics

Use 8080/6800-Series MPU Parallel Interface or Serial Interface

1:6800 Series MPU Parallel Interface

Conditions:

$$V_{DD} \sim V_{SS} = 2.4 \text{ to } 3.5\text{V}$$

$$T_A = 25^\circ\text{C}$$

6800-Series MPU Parallel Interface Timing Characteristics

Symbol	Parameter	Min	Typ	Max	Unit
t_{cycle}	Clock Cycle Time	300	-	-	ns
t_{AS}	Address Setup Time	0	-	-	ns
t_{AH}	Address Hold Time	0	-	-	ns
t_{DSW}	Write Data Setup Time	40	-	-	ns
t_{DHW}	Write Data Hold Time	15	-	-	ns
t_{DHR}	Read Data Hold Time	20	-	-	ns
t_{OH}	Output Disable Time	-	-	70	ns
t_{ACC}	Access Time	-	-	140	ns
PW_{CSL}	Chip Select Low Pulse Width (read)	120	-	-	ns
	Chip Select Low Pulse Width (write)	60	-	-	ns
PW_{CSH}	Chip Select High Pulse Width (read)	60	-	-	ns
	Chip Select High Pulse Width (write)	60	-	-	ns
t_R	Rise Time	-	-	15	ns
t_F	Fall Time	-	-	15	ns

6800-series MPU parallel interface characteristics

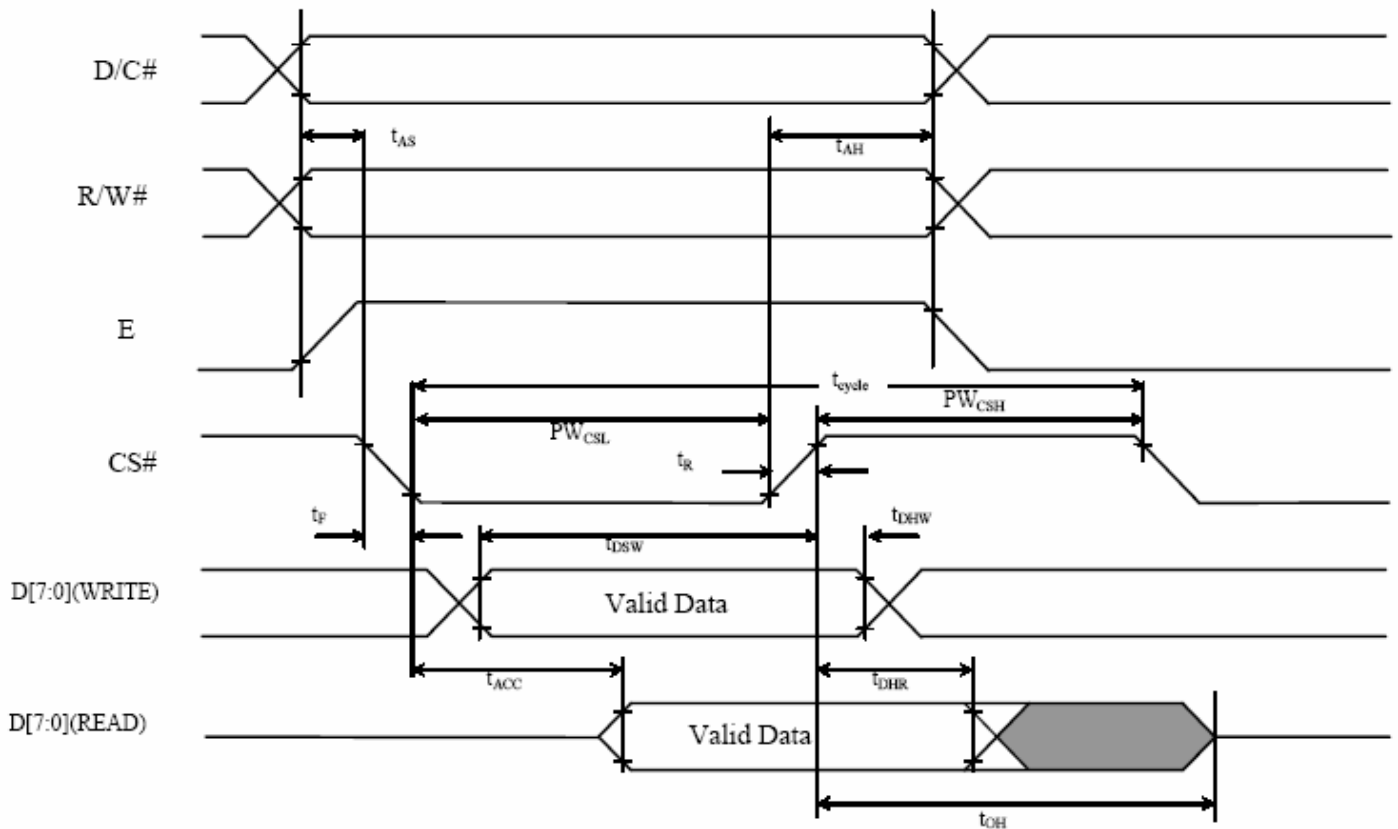

2:8080 Series MPU Parallel Interface

Conditions:

$V_{DD} \sim V_{SS} = 2.4 \text{ to } 3.5\text{V}$

$T_A = 25^\circ\text{C}$

8080-Series MPU Parallel Interface Timing Characteristics

Symbol	Parameter	Min	Typ	Max	Unit
t_{cycle}	Clock Cycle Time	300	-	-	ns
t_{AS}	Address Setup Time	0	-	-	ns
t_{AH}	Address Hold Time	0	-	-	ns
t_{DSW}	Write Data Setup Time	40	-	-	ns
t_{DHW}	Write Data Hold Time	15	-	-	ns
t_{DHR}	Read Data Hold Time	20	-	-	ns
t_{OH}	Output Disable Time	-	-	70	ns
t_{ACC}	Access Time	-	-	140	ns
PW_{CSL}	Chip Select Low Pulse Width (read)	120	-	-	ns
	Chip Select Low Pulse Width (write)	60	-	-	ns
PW_{CSH}	Chip Select High Pulse Width (read)	60	-	-	ns
	Chip Select High Pulse Width (write)	60	-	-	ns
t_R	Rise Time	-	-	15	ns
t_F	Fall Time	-	-	15	ns

8080-series MPU parallel interface characteristics

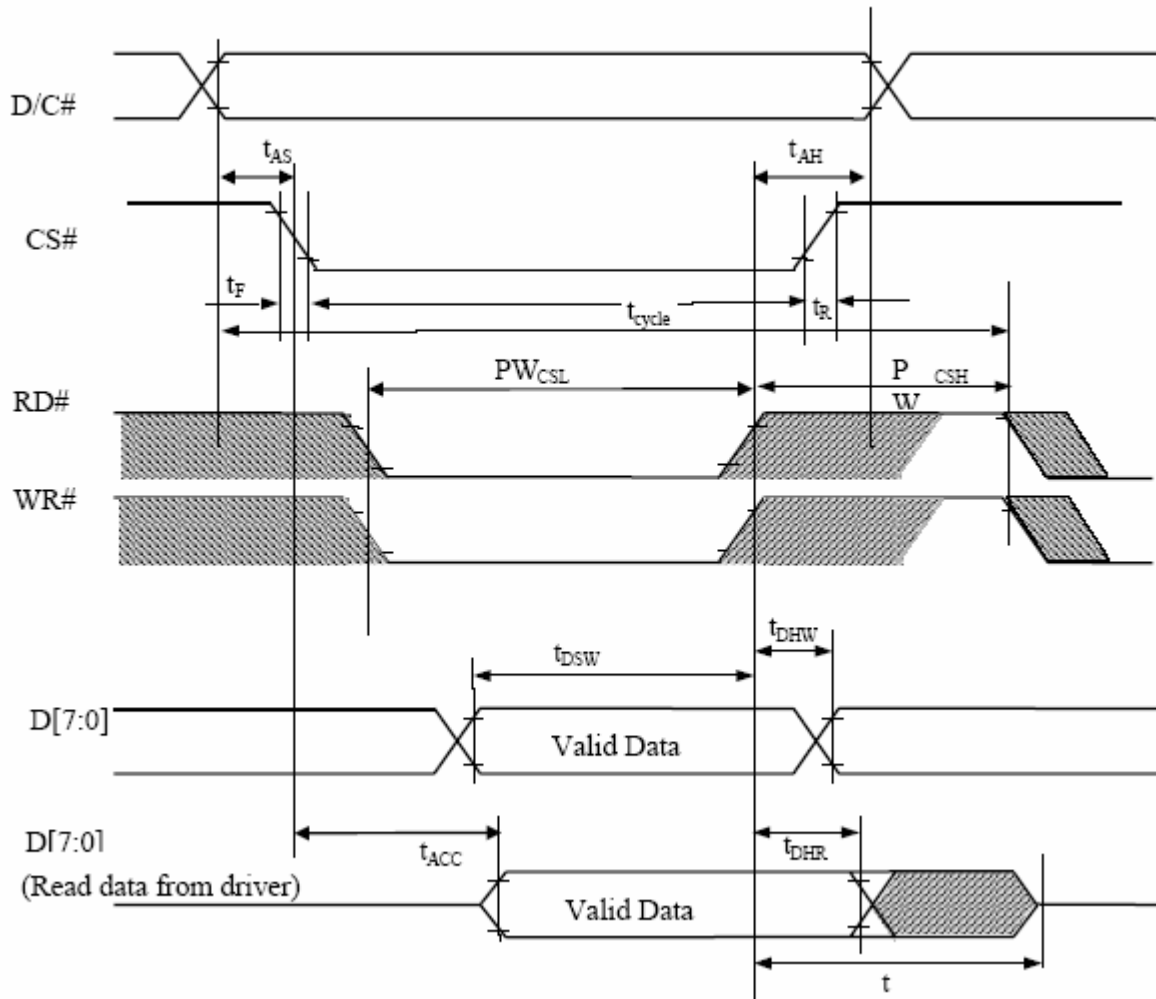

3:Serial Interface

Conditions:

$V_{DD} \sim V_{SS} = 2.4 \text{ to } 3.5\text{V}$

$T_A = 25^\circ\text{C}$

Serial Interface Timing Characteristics

Symbol	Parameter	Min	Typ	Max	Unit
t_{cycle}	Clock Cycle Time	250	-	-	ns
t_{AS}	Address Setup Time	150	-	-	ns
t_{AH}	Address Hold Time	150	-	-	ns
t_{CSS}	Chip Select Setup Time	120	-	-	ns
t_{CSH}	Chip Select Hold Time	60	-	-	ns
t_{DSW}	Write Data Setup Time	100	-	-	ns
t_{DHW}	Write Data Hold Time	100	-	-	ns
t_{CLKL}	Clock Low Time	100	-	-	ns
t_{CLKH}	Clock High Time	100	-	-	ns
t_R	Rise Time	-	-	15	ns
t_F	Fall Time	-	-	15	ns

Serial interface characteristics

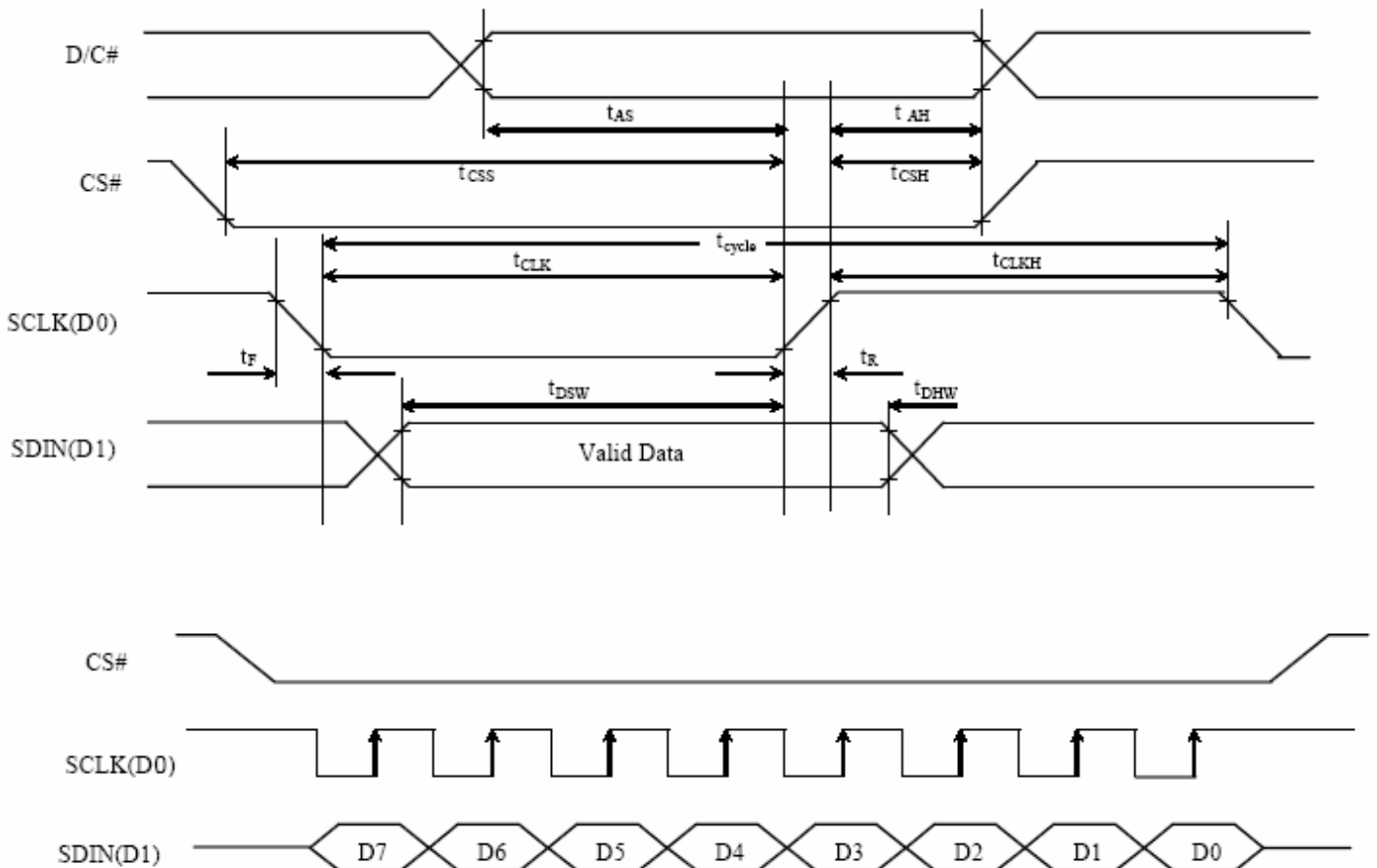

■ TIMING OF POWER SUPPLY

The following figures illustrate the recommended power ON and power OFF sequence of SSD1325.

Power ON sequence:

1. Power ON V_{DD} .
2. After V_{DD} become stable, set RES# pin LOW (logic LOW) for at least 3 μ s (t_1) and then HIGH (logic HIGH).
3. After set RES# pin LOW (logic LOW), wait for at least 3 μ s (t_2). Then Power ON V_{CC} .⁽¹⁾
4. After V_{CC} become stable, send command AFh for display ON. SEG/COM will be ON after 100ms (t_{AF}).

Figure 16 : The Power ON sequence

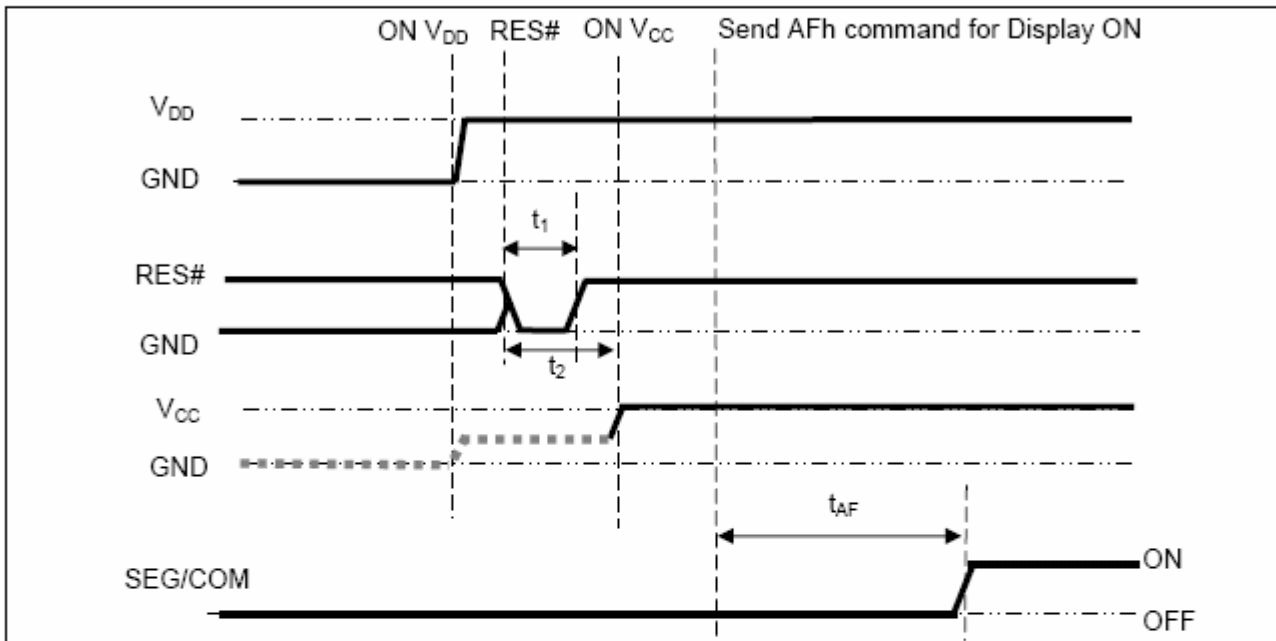

Power OFF sequence:

1. Send command AEh for display OFF.
2. Wait until panel discharges completely.
3. Power OFF V_{CC} .^{(1), (2)}
4. Wait for t_{OFF} . Power OFF V_{DD} . (where Minimum t_{OFF} =0ms, Typical t_{OFF} =100ms)

Figure 17 : The Power OFF sequence

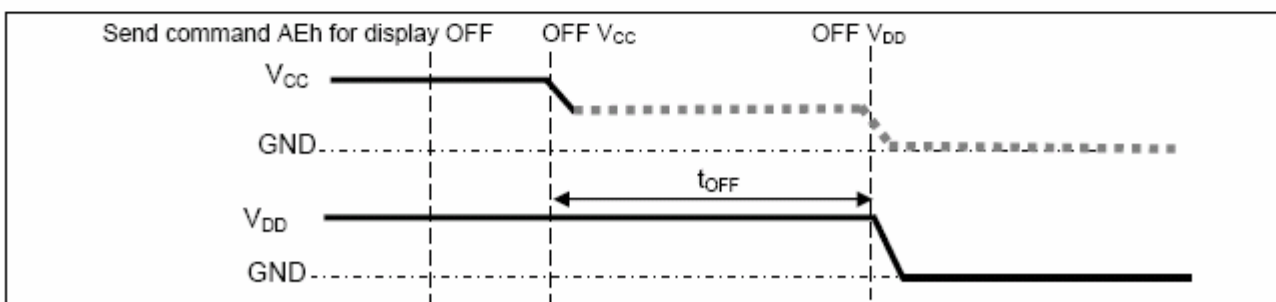

Note:

⁽¹⁾ Since an ESD protection circuit is connected between V_{DD} and V_{CC} , V_{CC} becomes lower than V_{DD} whenever V_{DD} is ON and V_{CC} is OFF as shown in the dotted line of V_{CC} in Figure 16 and Figure 17.

⁽²⁾ V_{CC} should be kept float when it is OFF.

■ **ELECTRO-OPTICAL CHARACTERISTICS (Ta=25°C)**

Items	Symbol	Min.	Typ.	Max.	Unit	Remark	
Operating Luminance	L	70	80*	-	cd /m ²	Yellow	
Power Consumption	P	-	80	90	mW	30% pixels ON L=80cd/m ²	
Frame Frequency	Fr	-	100	-	Hz		
Color Coordinate	YELLOW	CIE x	0.41	0.46	0.51	CIE1931	Darkroom
		CIE y	0.46	0.51	0.56		
Response Time	Rise	Tr	-	-	0.02	ms	-
	Decay	Td	-	-	0.02	ms	-
Contrast Ratio*	Cr	10000:1	-	-			Darkroom
Viewing Angle Uniformity	△ θ	160	-	-	Degree		-
Operating Life Time*	Top	100,000	-	-	Hours		L=80cd/m ²

Note:

1. **80cd/m²** is base on V_{DD}=3.0V, V_{PP}=12.0V, contrast command setting 0x40;
2. **Contrast ratio** is defined as follows:

$$\text{Contrast ratio} = \frac{\text{Photo - detector output with OLED being "white"}}{\text{Photo - detector output with OLED being "black"}}$$

3. **Life Time** is defined when the Luminance has decayed to less than 50% of the initial Luminance specification. (30% pixels scrolling display on)
(The initial value should be closed to the typical value after adjusting.)

■ **INTERFACE PIN CONNECTIONS**

No	Symbol	Description
1	NC	No connection
2	VCC	High voltage supply for OLED panel
3	VCOMH	High level voltage output of COM signal
4	IREF	Current reference pin
5	D7	Data bus or connected to Ground In SPI mode
6	D6	Data bus or connected to Ground In SPI mode
7	D5	Data bus or connected to Ground In SPI mode
8	D4	Data bus or connected to Ground In SPI mode
9	D3	Data bus or connected to Ground In SPI mode
10	D2	Data bus or left open In SPI mode
11	D1	Data bus or as SDIN In SPI mode
12	D0	Data bus or as SCLK In SPI mode
13	E/RD#	MCU interface input pin
14	W/R#	MCU interface input pin
15	D/C#	Data/Command data control pin
16	RES#	This pin is reset signal input .
17	CS#	The chip select pin. Low is enabled
18	NC	No connection
19	BS2	It is a switch to select the input data to parallel or series
20	BS1	It is the MPU interface switched pad(L:6800; H:8080)
21	VDD	Logic voltage supply for IC
22	NC	No connection
23	NC	No connection
24	NC	No connection
25	VBREF	This is reserved pin ,It should be keep NC
26	RESE	This is reserved pin ,It should be keep NC
27	FB	This is reserved pin ,It should be keep NC
28	VDDDB	This is reserved pin ,It should be connected to VDD
29	GDR	This is reserved pin ,It should be keep NC
30	VSS	Ground
31	VSL	This is the output pin for the voltage output low level for SEG signals. This pin can be kept NC or connected with a capacitor to VSS for stability. Refer to command BFh for VSL pin connection details.

■ **COMMAND TABLE**

(D/C# = 0, R/W# (WR#) = 0, E (RD#) = 1) unless specific setting is stated

Fundamental Command Table											
D/C	Hex	D7	D6	D5	D4	D3	D2	D1	D0	Command	Description
0 0 0	15 A[5:0] B[5:0]	0 * *	0 * *	0 A ₅ B ₅	1 A ₄ B ₄	0 A ₃ B ₃	1 A ₂ B ₂	0 A ₁ B ₁	1 A ₀ B ₀	Set Column Address	Second command A[5:0] sets the column start address from 0-63, POR = 00h Third command B[5:0] sets the column end address from 0-63, RESET = 3Fh
0 0 0	75 A[6:0] B[6:0]	0 * *	1 A ₆ B ₆	1 A ₅ B ₅	1 A ₄ B ₄	0 A ₃ B ₃	1 A ₂ B ₂	0 A ₁ B ₁	1 A ₀ B ₀	Set Row address	Second command A[6:0]sets the row start address from 0-79, RESET = 00h Third command B[6:0] sets the row end address from 0-79, RESET = 4Fh
0 0	81 A[6:0]	1 *	0 A ₆	0 A ₅	0 A ₄	0 A ₃	0 A ₂	0 A ₁	1 A ₀	Set Contrast Current	Double byte command to select 1 out of 128 contrast steps. Contrast increases as level increase The level is set to 40h after RESET
0	84~86	1	0	0	0	0	1	X ₁	X ₀	Set Current Range	84h = Quarter Current Range (RESET) 85h = Half Current Range 86h = Full Current Range
0 0	A0 A[6:0]	1 *	0 A ₆	1 A ₅	0 A ₄	0 A ₃	0 A ₂	0 A ₁	0 A ₀	Set Re-map	A[0]=0, Disable Column Address Re-map (RESET) A[0]=1, Enable Column Address Re-map A[1]=0, Disable Nibble Re-map (RESET) A[1]=1, Enable Nibble Re-map A[2]=0, Horizontal Address Increment (RESET) A[2]=1, Vertical Address Increment A[4]=0, Disable COM Re-map disable (RESET) A[4]=1, Enable COM Re-map A[5]=0, Reserved (RESET) A[5]=1, Reserved A[6]=0, Disable COM Split Odd Even (RESET) A[6]=1, Enable COM Split Odd Even
0 0	A1 A[6:0]	1 *	0 A ₆	1 A ₅	0 A ₄	0 A ₃	0 A ₂	0 A ₁	1 A ₀	Set Display Start Line	Set display RAM display start line register from 0-79 Display start line register is reset to 00h after RESET
0 0	A2 A[6:0]	1 *	0 A ₆	1 A ₅	0 A ₄	0 A ₃	0 A ₂	1 A ₁	0 A ₀	Set Display Offset	Set vertical scroll by COM from 0-79 The value is reset to 00H after RESET
0	A4~A7	1	0	1	0	0	X ₂	X ₁	X ₀	Set Display Mode	A4h = Normal Display (RESET) A5h = Entire Display ON,

Fundamental Command Table											
D/C	Hex	D7	D6	D5	D4	D3	D2	D1	D0	Command	Description
											all pixels turns ON in GS level 15 A6h = Entire Display OFF, all pixels turns OFF A7h = Inverse Display
0 0	A8 A[6:0]	1 *	0 A ₆	1 A ₅	0 A ₄	1 A ₃	0 A ₂	0 A ₁	0 A ₀	Set Multiplex Ratio	The next command determines multiplex ratio N from 16MUX-80MUX, A[6:0] = 15 represents 16MUX A[6:0] = 16 represents 17MUX : A[6:0] = 78 represents 79MUX A[6:0] = 79 represents 80MUX
0 0	AD A[1:0]	1 *	0 *	1 *	0 *	1 *	1 *	0 1	1 A ₀	Set Master Configuration	A[0] = 0, Select external V _{CC} supply A[0] = 1, Reserved (RESET) Note (¹) Bit A[0] must be set to 0b after RESET. (²) The setting will be activated after issuing Set Display ON command (AFh)
0	AE	1	0	1	0	1	1	1	0	Set Display ON	A Eh = Display OFF (Sleep mode) (RESET)
0	AF	1	0	1	0	1	1	1	1	Set Display OFF	AFh = Display ON
0 0	B0 A[5:0]	1 *	0 *	1 A ₅	1 A ₄	0 A ₃	0 A ₂	0 A ₁	0 A ₀	Set Pre-charge Compensation Enable	A[5:0] = 08h (RESET) A[5:0] = 28h, Enable pre-charge compensation
0 0 0	B1 A[3:0] A[7:4]	1 * A ₇	0 * A ₆	1 * A ₅	1 * A ₄	0 A ₃	0 A ₂	0 A ₁	1 A ₀	Set Phase Length	A[3:0] = P1, phase 1 period of 1-15 DCLKs, RESET = 3DCLKS = 3h A[7:4] = P2, phase 2 period of 1-15 DCLKs, RESET = 5DCLKS = 5h Note (¹) 0 DCLK is invalid in phase 1 & phase 2
0 0	B2 A[7:0]	1 A ₇	0 A ₆	1 A ₅	1 A ₄	0 A ₃	0 A ₂	1 A ₁	0 A ₀	Set Row Period (set frame frequency)	The next command sets the number of DCLKs, K, per row between 2-158 DCLKS RESET = 37DCLKS = 25h The K value should be set as K = P1+P2+GS15 pulse width (RESET: 3+5+29DCLKS)
0 0 0	B3 A[3:0] A[7:4]	1 * A ₇	0 * A ₆	1 * A ₅	1 * A ₄	0 A ₃	0 A ₂	1 A ₁	1 A ₀	Set Display Clock Divide Ratio / Oscillator Frequency	The lower nibble (A[3:0]) of the next command defines the divide ratio (D) of display clock (DCLK) Divide ratio (D)=A[3:0]+1 (A[3:0]RESET is 0001b, i.e. divide ratio (D) = 2)

Fundamental Command Table											
D/C	Hex	D7	D6	D5	D4	D3	D2	D1	D0	Command	Description
											The higher nibble (A[7:4]) of the next command sets the Oscillator Frequency Oscillator Frequency increases with the value of A[7:4] and vice versa Range: 0000b~1111b RESET= 0100b represents 655KHz, typical step value: 5% of previous value
0 0	B4 A[2:0]	1 *	0 *	1 *	1 *	0 *	1 A ₂	0 A ₁	0 A ₀	Set Pre-charge Compensation Level	A[2:0] = 0 (RESET) A[2:0] = 3h, Recommended level
0 0 0 0 0 0 0 0 0 0 0 0 0 0 0 0 0 0 0 0	B8 A[2:0] B[2:0] B[6:4] C[2:0] C[6:4] D[2:0] D[6:4] E[2:0] E[6:4] F[2:0] F[6:4] G[2:0] G[6:4] H[2:0] H[6:4]	1 * * * * * * * * * * * * * * * * * * *	0 * * B ₆ * C ₆ * D ₆ * E ₆ * F ₆ * G ₆ * H ₆	1 * * B ₅ * C ₅ * D ₅ * E ₅ * F ₅ * G ₅ * H ₅	1 * * B ₄ * C ₄ * D ₄ * E ₄ * F ₄ * G ₄ * H ₄	1 * * * * * * * * * * * * * * * * * * *	0 A ₂ B ₂ * C ₂ * D ₂ * E ₂ * F ₂ * G ₂ * H ₂	0 A ₁ B ₁ * C ₁ * D ₁ * E ₁ * F ₁ * G ₁ * H ₁	0 A ₀ B ₀ * C ₀ * D ₀ * E ₀ * F ₀ * G ₀ * H ₀	Set Gray Scale Table	The next eight bytes of command set the gray scale level of GS1-15 as below: A[2:0] = Gray scale level of GS1, RESET=1 B[2:0] = Gray scale level of GS2, RESET=1 B[6:4] = Gray scale level of GS3, RESET=1 C[2:0] = Gray scale level of GS4, RESET=1 C[6:4] = Gray scale level of GS5, RESET=1 D[2:0] = Gray scale level of GS6, RESET=1 D[6:4] = Gray scale level of GS7, RESET=1 E[2:0] = Gray scale level of GS8, RESET=1 E[6:4] = Gray scale level of GS9, RESET=1 F[2:0] = Gray scale level of GS10, RESET=1 F[6:4] = Gray scale level of GS11, RESET=1 G[2:0] = Gray scale level of GS12, RESET=1 G[6:4] = Gray scale level of GS13, RESET=1 H[2:0] = Gray scale level of GS14, RESET=1 H[6:4] = Gray scale level of GS15, RESET=1
0 0	BC A[7:0]	1 A ₇	0 A ₆	1 A ₅	1 A ₄	1 A ₃	1 A ₂	0 A ₁	0 A ₀	Set Precharge Voltage	Second command A[7:0] sets the precharge voltage level, A[7:0] 1xxxxxxx connects to V _{COMH} (RESET) 001xxxxxx 1.0 * V _{REF} 00000000 0.51* V _{REF} 00000001 0.52* V _{REF} 00011111 0.84* V _{REF}
0 0	BE A[4:0]	1 *	0 *	1 0	1 A ₄	1 A ₃	1 A ₂	1 A ₁	0 A ₀	Set V _{COMH} Voltage	Second command A[4:0] sets the V _{COMH} voltage level , A[4:0] 00000 0.51*V _{REF} 00001 0.52* V _{REF} 11101 0.81* V _{REF} (RESET) 11110 0.82* V _{REF} 11111 0.84* V _{REF}
0 0	BF A[3:0]	1 *	0 *	1 *	1 *	1 A ₃	1 A ₂	1 A ₁	1 A ₀	Set Segment Low Voltage (VSL)	Second command A[3:0] sets the VSL voltage as follow: A[3:0] = 0010 kept VSL pin NC A[3:0] = 1110 (RESET) connect a capacitor between VSL pin and V _{SS}
0	E3	1	1	1	0	0	0	1	1	NOP	Command for No Operation

◆ **Read command table**

(D/C#=0, R/W#(WR#)=1, E(RD#)=1 for 6800 or E(RD#)=0 for 8080)

D ₇ D ₆ D ₅ D ₄ D ₃ D ₂ D ₁ D ₀	Status Register Read	D7 = 0:reserved D7 = 1:reserved D6 = 0:indicates the display is ON D6 = 1:indicated the display is OFF D5 = 0:reserved D5 = 1:reserved D4 = 0:reserved D4 = 1:reserved
---	----------------------	---

Note: Patterns other than that given in Command Table are prohibited to enter to the chip as a command;
 Otherwise, unexpected result will occur

■ INTIALIZATION CODE

```
Void init_oled()
{
    W_COMMAND(0x15); //SET COLUMN ADDRESS
    W_COMMAND(0x00);
    W_COMMAND(0x3F);
    W_COMMAND(0x75); //SET ROW ADDRESS
    W_COMMAND(0x00);
    W_COMMAND(0x3F);

    W_COMMAND(0x81); //SET CONTRAST CURRENT
    W_COMMAND(0x40);

    W_COMMAND(0x86); //SET CURRENT RANGE

    W_COMMAND(0xA0); //SET RE_MAP
    W_COMMAND(0x52);

    W_COMMAND(0xA1); //SET DISPLAY START LINE
    W_COMMAND(0x00);

    W_COMMAND(0xA2); //SET DISPLAY OFFSET
    W_COMMAND(0x40);

    W_COMMAND(0xA4); //SET DISPLAY MODE(A4:NORMAL,A5:ENTIRE ON,A6:ENTIRE
                        OFF,A7:INVERSE)

    W_COMMAND(0xA8); //SET MULTIPLEX RATIO
    W_COMMAND(0x3F); //16--80

    W_COMMAND(0xAD); //SET MASTER CONFIGURATION
    W_COMMAND(0x02); //select external vcc supply

    W_COMMAND(0xB0); //SET PRE-CHARGE COMPENSATION ENABLE
    W_COMMAND(0x28); //28,ENABLE PRE-CHARGE COMPENSATION

    W_COMMAND(0xB1); //SET PHASE LENGTH
    W_COMMAND(0x23);

    W_COMMAND(0xB2); //SET ROW PERIOD(FRAME FREQUENCY)
    W_COMMAND(0x46); //K=P1+P2+GS15 PULSE WIDTH

    W_COMMAND(0xB3); //SET DISPLAY CLOCK DIVIDE RATIO/OSCILLATOR FREQUENCY
    W_COMMAND(0x40); //655KHz,D=2

    W_COMMAND(0xB4); //SET PRE-CHARGE COMPENSATION LEVEL
    W_COMMAND(0x03);

    W_COMMAND(0xB8); //SET GRAY SCALE TABLE
    W_COMMAND(0x01); //GS1
    W_COMMAND(0x11); //GS3GS2
    W_COMMAND(0x22); //GS5GS4
```

```
W_COMMAND(0x32); //GS7GS6
W_COMMAND(0x43); //GS9GS8
W_COMMAND(0x54); //GS11GS10
W_COMMAND(0x65); //GS13GS12
W_COMMAND(0x76); //GS15GS14
```

```
W_COMMAND(0xBC); //SET PRE-CHARGE VOLTAGE
W_COMMAND(0x1F);
```

```
W_COMMAND(0xBE); //SET VCOMH VOLTAGE
W_COMMAND(0x10);
```

```
W_COMMAND(0xBF); //SET SEGMENT LOW VOLTAGE(VSL)
W_COMMAND(0x0E);
```

```
W_COMMAND(0xAF); //DISPLAY ON
```

```
}
```

■ SCHEMATIC EXAMPLE

◆ 8080 Series Interface Application Circuit(External V_{CC}=12.0V):

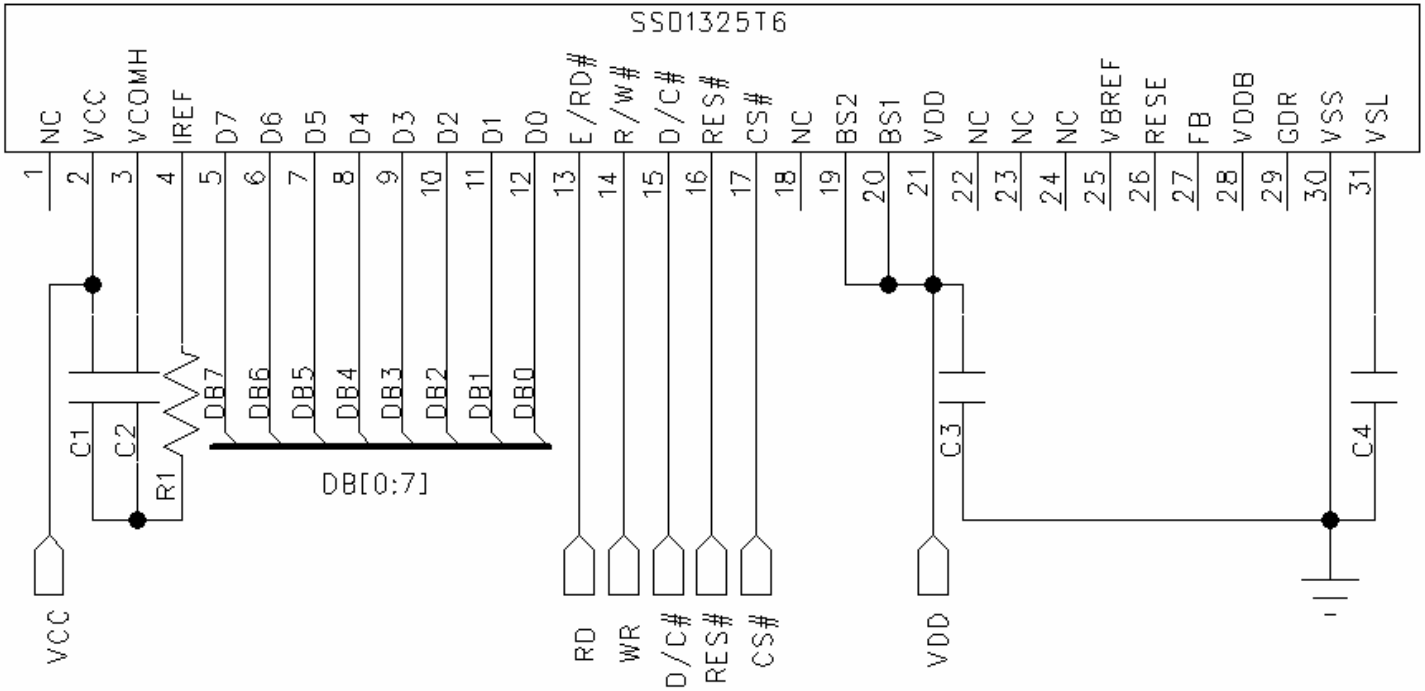

◆ Serial Interface Application Circuit(External V_{CC}=12.0V):

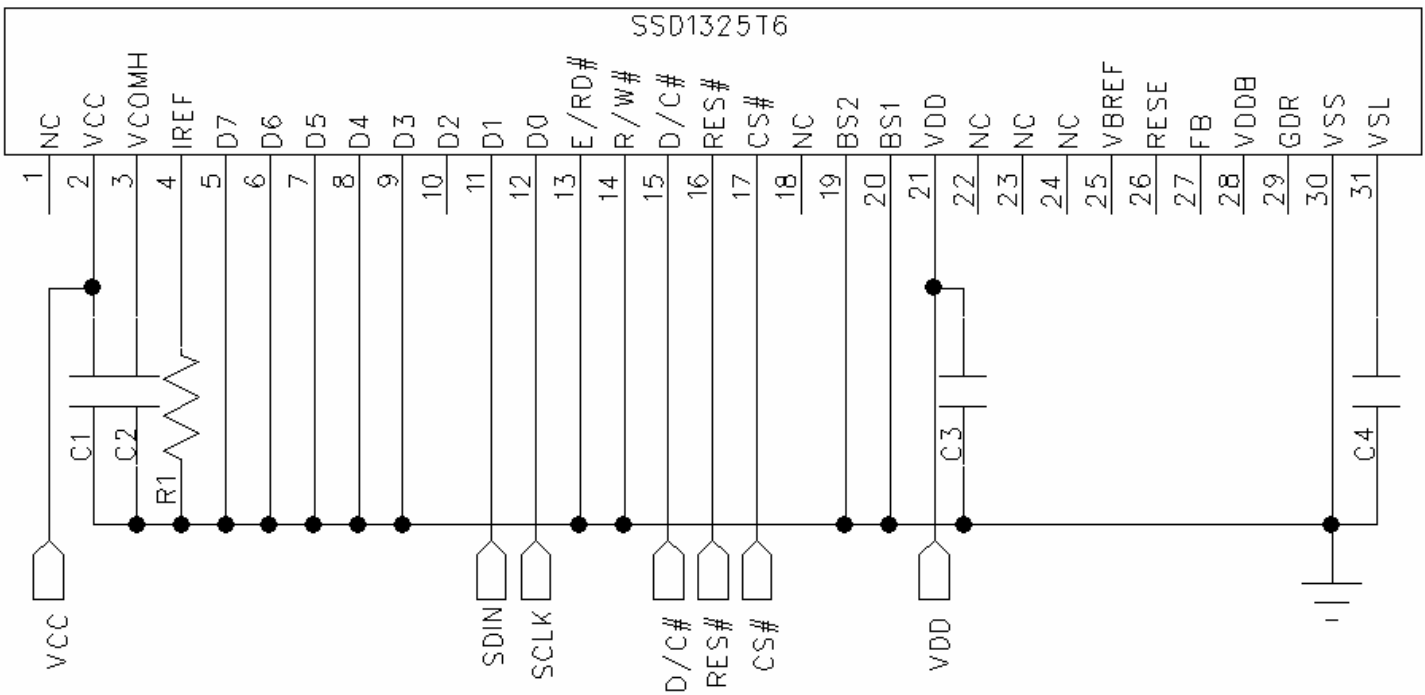

NOTE:

1. $R1 = (V_{CC} - 3)V / 10\mu A = (12 - 3)V / 10\mu A \approx 910K\Omega$, $C1 = C2 = C3 = 4.7\mu F$, $C4 = 1.0\mu F$;
2. The V_{CC} should connect a external voltage;
3. VBREF、RESE、FB、VDDDB and GDR pin should be open;
4. In Serial interface mode, only write operations are allowed.

■ **RELIABILITY TESTS**

Item		Condition	Criterion
High Temperature Storage (HTS)		80±2°C , 200 hours	1. After testing, the function test is ok. 2. After testing, no addition to the defect. 3. After testing, the change of luminance should be within +/- 50% of initial value. 4. After testing, the change for the mono and area color must be within (+/-0.02, +/- 0.02) and for the full color it must be within (+/-0.04, +/-0.04) of initial value based on 1931 CIE coordinates. 5. After testing, the change of total current consumption should be within +/- 50% of initial value.
High Temperature Operating (HTO)		70±2°C , 96 hours	
Low Temperature Storage (LTS)		-30±2°C , 200 hours	
Low Temperature Operating (LTO)		-20±2°C , 96 hours	
High Temperature / High Humidity Storage (HTHHS)		50±3°C , 90%±3%RH, 120 hours	
Thermal Shock (Non-operation) (TS)		-20±2°C ~ 25°C ~ 70±2°C (30min) (5min) (30min) 10cycles	
Vibration (Packing)	10~55~10Hz, amplitude 1.5mm, 1 hour for each direction x, y, z	1. One box for each test. 2. No addition to the cosmetic and the electrical defects.	
Drop (Packing)	Height : 1 m, each time for 6 sides, 3 edges, 1 angle		
ESD (finished product housing)	±4kV (R: 330Ω C: 150pF , 10times, air discharge)	1. After testing, cosmetic and electrical defects should not happen. 2. In case of malfunction or defect caused by ESD damage, it would be judged as a good part if it would be recovered to normal state after resetting.	

- Note: 1) For each reliability test, the sample quantity is 3, and only for one test item.
 2) The HTHHS test is requested the Pure Water(Resistance>10MΩ).
 3) The test should be done after 2 hours of recovery time in normal environment.

■OUTGOING QUALITY CONTROL SPECIFICATION

◆Standard

According to GB/T2828.1-2003/ISO 2859-1: 1999 and ANSI/ASQC Z1.4-1993, General Inspection Level II.

◆Definition

- 1 Major defect : The defect that greatly affect the usability of product.
- 2 Minor defect : The other defects, such as cosmetic defects, etc.
- 3 Definition of inspection zone:

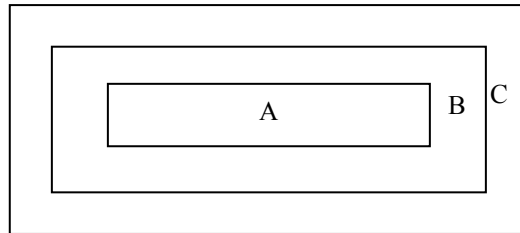

Zone A: Active Area

Zone B: Viewing Area except Zone A

Zone C: Outside Viewing Area

Note: As a general rule, visual defects in Zone C are permissible, when it is no trouble of quality and assembly to customer`s product.

◆Inspection Methods

- 1 The general inspection : under 20W x 2 or 40W fluorescent light, about 30cm viewing distance, within 45° viewing angle, under 25±5°C.

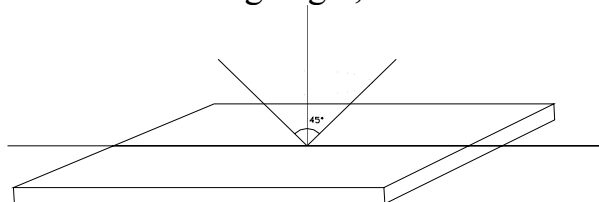

- 2 The luminance and color coordinate inspection : By PR705 or BM-7 or the equal equipments, in the dark room, under 25±5°C.

◆Inspection Criteria

- 1 Major defect : AQL= 0.65

Item	Criterion
Function Defect	1. No display or abnormal display is not accepted
	2. Open or short is not accepted.
	3. Power consumption exceeding the spec is not accepted.
Outline Dimension	Outline dimension exceeding the spec is not accepted.
Glass Crack	Glass crack tends to enlarge is not accepted.

- 2 Minor Defect : AQL= 1.5

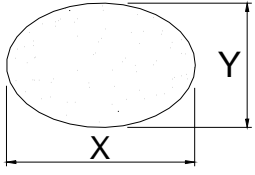
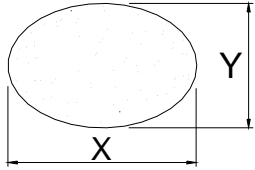
Item	Criterion			
Spot Defect (dimming and lighting spot)	Size (mm)		Accepted Qty	
			Area A + Area B	Area C
		$\Phi \leq 0.10$	Ignored	
		$0.10 < \Phi \leq 0.15$	3	Ignored
		$0.15 < \Phi \leq 0.20$	1	
$0.20 < \Phi$		0		
Note : $\Phi = (x + y) / 2$				
Line Defect (dimming and lighting line)	L (Length) : mm	W (Width) : mm	Area A + Area B	Area C
	/	$W \leq 0.03$	Ignored	
	$L \leq 3.0$	$0.03 < W \leq 0.05$	2	Ignored
	$L \leq 2.0$	$0.05 < W \leq 0.08$	1	
	/	$0.08 < W$	As spot defect	
Remarks: The total of spot defect and line defect shall not exceed 4 pcs.				
Polarizer Stain	Stain which can be wiped off lightly with a soft cloth or similar cleaning is accepted, otherwise, according to the Spot Defect and the Line Defect.			
Polarizer Scratch	1. If scratch can be seen during operation, according to the criterions of the Spot Defect and the Line Defect.			
	2. If scratch can be seen only under non-operation or some special angle, the criterion is as below :			
	L (Length) : mm	W (Width) : mm	Area A + Area B	Area C
	/	$W \leq 0.03$	Ignore	
	$5.0 < L \leq 10.0$	$0.03 < W \leq 0.05$	2	Ignore
	$L \leq 5.0$	$0.05 < W \leq 0.08$	1	
/	$0.08 < W$	0		
Polarizer Air Bubble	Size		Area A + Area B	Area C
		$\Phi \leq 0.20$	Ignored	
		$0.20 < \Phi \leq 0.50$	2	Ignored
		$0.50 < \Phi \leq 0.80$	1	
		$0.80 < \Phi$	0	

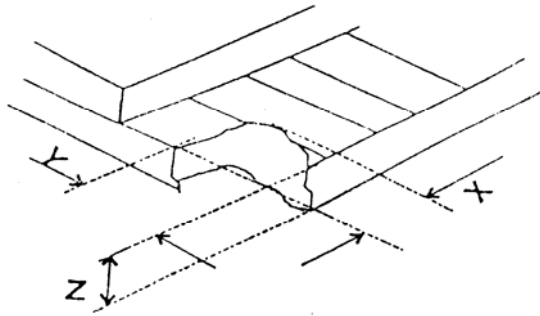
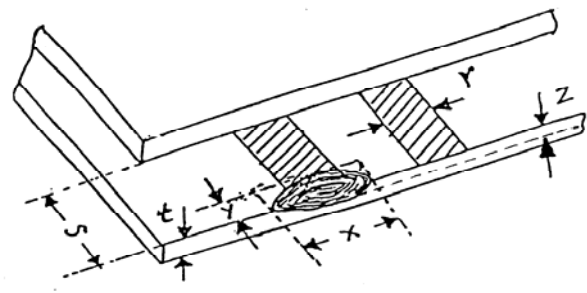
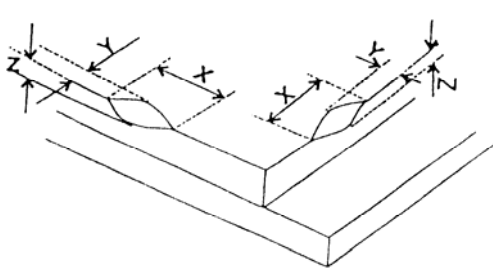
Glass Defect (Glass Chipped)	<p>1. On the corner</p>  <p style="text-align: right;">(mm)</p> <table border="1" style="margin-left: auto;"> <tr> <td>x</td> <td>≤ 2.0</td> </tr> <tr> <td>y</td> <td>$\leq S$</td> </tr> <tr> <td>z</td> <td>$\leq t$</td> </tr> </table>	x	≤ 2.0	y	$\leq S$	z	$\leq t$
	x	≤ 2.0					
	y	$\leq S$					
	z	$\leq t$					
<p>2. On the bonding edge</p>  <p style="text-align: right;">(mm)</p> <table border="1" style="margin-left: auto;"> <tr> <td>x</td> <td>$\leq a / 2$</td> </tr> <tr> <td>y</td> <td>$\leq s / 3$</td> </tr> <tr> <td>z</td> <td>$\leq t$</td> </tr> </table>	x	$\leq a / 2$	y	$\leq s / 3$	z	$\leq t$	
x	$\leq a / 2$						
y	$\leq s / 3$						
z	$\leq t$						
<p>3. On the other edges</p>  <p style="text-align: right;">(mm)</p> <table border="1" style="margin-left: auto;"> <tr> <td>x</td> <td>$\leq a / 5$</td> </tr> <tr> <td>y</td> <td>≤ 1.0</td> </tr> <tr> <td>z</td> <td>$\leq t$</td> </tr> </table>	x	$\leq a / 5$	y	≤ 1.0	z	$\leq t$	
x	$\leq a / 5$						
y	≤ 1.0						
z	$\leq t$						
<p>Note: t: glass thickness ; s: pad width ; a: the length of the edge</p>							
TCP Defect	Crack, deep fold and deep pressure mark on the TCP are not accepted						
Pixel Size	The tolerance of display pixel dimension should be within $\pm 20\%$ of the spec						
Luminance	Refer to the spec or the reference sample						
Color	Refer to the spec or the reference sample						

■ CAUTIONS IN USING OLED MODULE**◆ Precautions For Handling OLED Module:**

1. OLED module consists of glass and polarizer. Pay attention to the following items when handling:
 - i. Avoid drop from high, avoid excessive impact and pressure.
 - ii. Do not touch, push or rub the exposed polarizers with anything harder than an HB pencil lead.
 - iii. If the surface becomes dirty, breathe on the surface and gently wipe it off with a soft dry cloth. If it is terrible dirty, moisten the soft cloth with Isopropyl alcohol or Ethyl alcohol. Other solvents may damage the polarizer. Especially water, Ketone and Aromatic solvents.
 - iv. Wipe off saliva or water drops immediately, contact the polarizer with water over a long period of time may cause deformation.
 - v. Please keep the temperature within specified range for use and storage. Polarization degradation, bubble generation or polarizer peeling-off may occur with high temperature and high humidity.
 - vi. Condensation on the surface and the terminals due to cold or anything will damage, stain or dirty the polarizer, so make it clean as the way of iii.
2. Do not attempt to disassemble or process the OLED Module.
3. Make sure the TCP or the FPC of the Module is free of twisting, warping and distortion, do not pull or bend them forcefully, especially the soldering pins. On the other side, the SLIT part of the TCP is made to bend in the necessary case.
4. When assembling the module into other equipment, give the glass enough space to avoid excessive pressure on the glass, especially the glass cover which is much more fragile.
5. Be sure to keep the air pressure under 120 kPa, otherwise the glass cover is to be cracked.
6. Be careful to prevent damage by static electricity:
 - i. Be sure to ground the body when handling the OLED Modules.
 - ii. All machines and tools required for assembling, such as soldering irons, must be properly grounded.
 - iii. Do not assemble and do no other work under dry conditions to reduce the amount of static electricity generated. A relative humidity of 50%-60% is recommended.
 - iv. Peel off the protective film slowly to avoid the amount of static electricity generated.
 - v. Avoid to touch the circuit, the soldering pins and the IC on the Module by the body.
 - vi. Be sure to use anti-static package.
7. Contamination on terminals can cause an electrochemical reaction and corrode the terminal circuit, so make it clean anytime.
8. All terminals should be open, do not attach any conductor or semiconductor on the terminals.
9. When the logic circuit power is off, do not apply the input signals.
10. Power on sequence: $V_{DD} \rightarrow V_{CC}$, and power off sequence: $V_{CC} \rightarrow V_{DD}$.
11. Be sure to keep temperature, humidity and voltage within the ranges of the spec, otherwise shorten Module's life time, even make it damaged.
12. Be sure to drive the OLED Module following the Specification and datasheet of IC controller, otherwise something wrong may be seen.

13. When displaying images, keep them rolling, and avoid one fixed image displaying more than 30 seconds, otherwise the residue image is to be seen. This is the speciality of OLED.

◆ **Precautions For Soldering OLED Module:**

1. Soldering temperature : $260^{\circ}\text{C} \pm 10^{\circ}\text{C}$.
2. Soldering time : 3-4 sec.
3. Repeating time : no more than 3 times.
4. If soldering flux is used, be sure to remove any remaining flux after finishing soldering operation. (This does not apply in the case of a non-halogen type of flux.) It is recommended to protect the surface with a cover during soldering to prevent any damage due to flux spatters.

◆ **Precautions For Storing OLED Module:**

1. Be sure to store the OLED Module in the vacuum bag with dessicant.
2. If the Module can not be used up in 1 month after the bag being opened, make sure to seal the Module in the vacuum bag with dessicant again.
3. Store the Module in a dark place, do not expose to sunlight or fluorescent light.
4. The polarizer surface should not touch any other objects. It is recommended to store the Module in the shipping container.
5. It is recommended to keep the temperature between 0°C and 30°C , the relative humidity not over 60%.

◆ **Limited Warranty**

Unless relevant quality agreements signed with customer and law enforcement, for a period of 12 months from date of production, all products (except automotive products) TRULY will replace or repair any of its OLED modules which are found to be functional defect when inspected in accordance with TRULY OLED acceptance standards (copies available upon request). Cosmetic/visual defects must be returned to TRULY within 90 days of shipment. Confirmation of such date should be based on freight documents. The warranty liability of TRULY is limited to repair and/or replacement on the terms above. TRULY will not be responsible for any subsequent or consequential events.

◆ **Return OLED Module Under Warranty:**

1. No warranty in the case that the precautions are disregarded.
2. Module repairs will be invoiced to the customer upon mutual agreement. Modules must be returned with sufficient description of the failures or defects.

◆ **PRIOR CONSULT MATTER**

1. For TRULY standard products ,we keep the right to change material ,process ... for improving the product property without any notice on our customer.
2. If you have special requirement about reliability condition, please let us know before you start the test on our samples.