

規格承認書

APPROVAL SHEET

客戶：
CUSTOMER

信利半导体有限公司

品名：
DESC

FPC Connector 0.5mm*60P*H2.0*锁扣下接

料號：
PART NO.

FZ-0520-60-LRSL

承認單位 DEPT.	採購部 PURCHASING	品管部 QC	工程部 R&D	零件承認章 APPROVAL SIGNET
審 核 CHECK				
確 認 APPROVAL				
審 核 結 果 INSPEC.RESULT :	<input type="checkbox"/> 合格 <input type="checkbox"/> 不合格			
	說 明 EXPOS : _____			
樣 品 數 量 SAMPLE Q'TY :	承 認 書 份 數 COPIES :	一 式 一 份	送 承 認 日 期 DATE :	



奕龍電子（香港）有限公司

YI LONG ELECTRONICS (HK) CO.,LTD

深圳市奕龍達科技發展有限公司

SHENZHEN YILONGDA TECHNOLOGY&DEVELOP CO.,LTD

TEL: 86-755-82863253 82863258 FAX:86-755-82863195

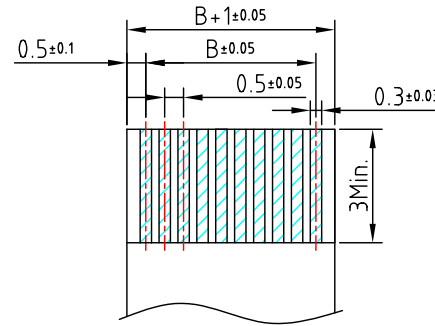
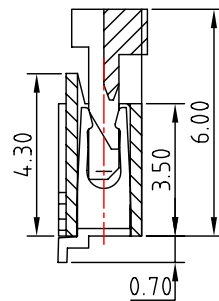
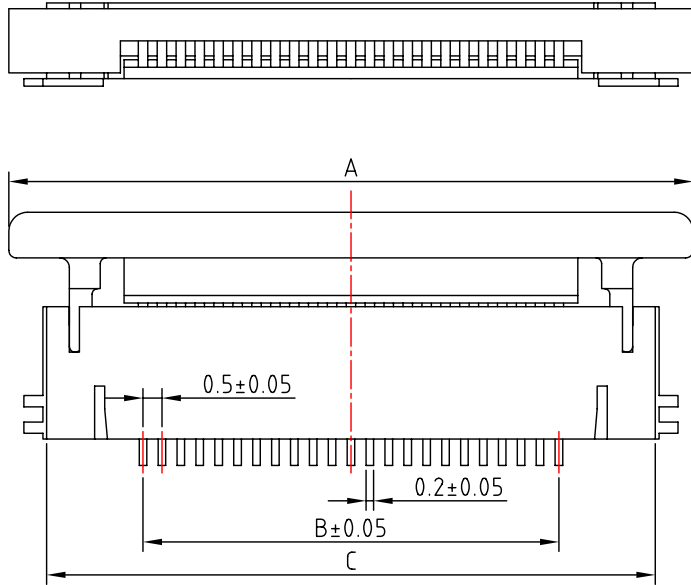

FPC/FFC DIMENSION
THICKNESS 0.3±0.03mm

NOTE:

1.MATERIALS

HOUSING:PA46 UL94V-0

COVER:PA9T UL94V-0

CONTACT: PHOSPHOR BRONZE

STOPPER:BRASS

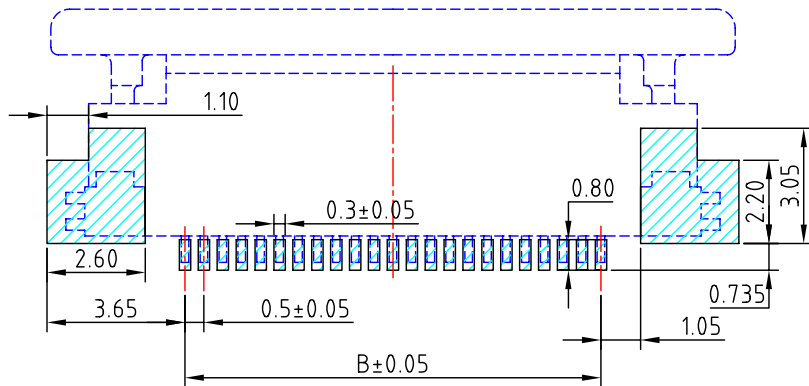

RECOMMENDED PCB LAYOUT

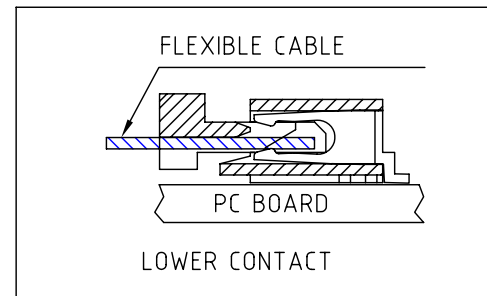

Pin	DIM A	DIM B	DIM C
3	8.10	1.0	6.10
4	8.60	1.5	6.60
5	9.10	2.0	7.10
6	9.60	2.5	7.60
7	10.10	3.0	8.10
8	10.60	3.5	8.60
9	11.10	4.0	9.10
10	11.60	4.5	9.60
11	12.10	5.0	10.10
12	12.60	5.5	10.60
13	13.10	6.0	11.10
14	13.60	6.5	11.60
15	14.10	7.0	12.10
16	14.60	7.5	12.60
17	15.10	8.0	13.10
18	15.60	8.5	13.60
19	16.10	9.0	14.10
20	16.60	9.5	14.60
21	17.10	10.0	15.10
22	17.60	10.5	15.60
23	18.10	11.0	16.10
24	18.60	11.5	16.60
25	19.10	12.0	17.10
26	19.60	12.5	17.60
27	20.10	13.0	18.10
28	20.60	13.5	18.60
29	21.10	14.0	19.10
30	21.60	14.5	19.60
31	22.10	15.0	20.10

Pin	DIM A	DIM B	DIM C
32	22.60	15.5	20.60
33	23.10	16.0	21.10
34	23.60	16.5	21.60
35	24.10	17.0	22.10
36	24.60	17.5	22.60
37	25.10	18.0	23.10
38	25.60	18.5	23.60
39	26.10	19.0	24.10
40	26.60	19.5	24.60
41	27.10	20.0	25.10
42	27.60	20.5	25.60
43	28.10	21.0	26.10
44	28.60	21.5	26.60
45	29.10	22.0	27.10
46	29.60	22.5	27.60
47	30.10	23.0	28.10
48	30.60	23.5	28.60
49	31.10	24.0	29.10
50	31.60	24.5	29.60
51	32.10	25.0	30.10
52	32.60	25.5	30.60
53	33.10	26.0	31.10
54	33.60	26.5	31.60
55	34.10	27.0	32.10
56	34.60	27.5	32.60
57	35.10	28.0	33.10
58	35.60	28.5	33.60
59	36.10	29.0	34.10
60	36.60	29.5	34.60

通用公差 GENERAL TOLERANCE	
X. ±0.20	X. ° ±1°
X. X ±0.10	X. X° ±0.5°
X. XX ±0.05	X. XX° ±0.25°

绘图 DESIGNED BY	Tom	校对 CHECKED BY	Minnie	审批 APPROVED BY	King	日期 DATE	2006/07/15	单位 UNIT	mm	比例 SCALE	FIT
奕龙电子(香港)有限公司 YI LONG ELECTRONICS (HK) CO.,LTD 深圳市奕龙达科技发展有限公司 SHENZHEN YILONGDA TECHNOLOGY DEVELOP CO.,LTD						品名 TITLE	FPC Connector 0.5mm×H2.0×锁扣贴片下接		角法 PROJECTION		
						料号 SCALE	FZ-0520-XX-LRSL		页码 SHEET	1/1	



產 品 規 格 書

PRODUCT SPECIFICATION

【1】適用範圍 SCOPE

本規格書適用於：FPC/FFC 連接器 0.5 間距高 2.0 鎖扣臥貼下接式系列

This specification covers the FPC/FFC Connectors 0.5mm H 2.0mm Pitch Lock Right Angle SMT Lower series

【2】產品名稱及型號 PRODUCT NAME AND PART NUMBER

PART NO. : FZ-0520-XX-LRSL-XX-XX

系列名稱 Series name	FZ
系列編號 Series NO.	0520
接點數量 NO. of contacts	04 ~ 60
組合樣式 Assembly style	LRSL-鎖扣臥貼下接式 Lock Right Angle SMT Lower
包裝方式 Packaging	TA-卷帶包裝 Embossed Tape TB-管裝 Tube
電鍍方式 Plating	NT-鎳底鍍錫 Tin over Nickel XG-鎳底鍍 X μ " 金 X μ " Gold over Nickel

【3】外觀尺寸 CONNECTOR DIMENSIONS

請參考圖面

See attached drawings



【4】建議 P.C.B LAYOUT 圖 ACCOMMODATED P.C.B LAYOUT

請參考圖面
See attached drawings

【5】材質 MATERIAL

主體 Housing	Glass-Filled PA46 顏色 Color: 白色 White 耐燃等級(UL94V-0) Flammability Rating(UL94V-0)
蓋子 Actuator	Glass-Filled PA9T 顏色 Color: 黑色 Black 耐燃等級(UL94V-0) Flammability Rating(UL94V-0)
端子 Contacts	磷青銅 Phosphor Bronze
定位片 Stopper	黃銅 Brass
電鍍方式 Plating	視定單需求 See Ordering Information

【6】規格 RATINGS

項目 Item	規格 Standard
額定電壓 Voltage Rating (MAX.)	50V AC
額定電流 Current Rating (MAX.)	0.5A DC
使用溫度範圍 Operating Temperature	-40 ~ +80 (包含電流通過所產生的上升溫度) -40 ~ +80 (Including terminal temperature rise)

【7】性能 PERFORMANCE

7.1 電氣性能 Electrical Performance



項目 Item	條件 Test Condition	規格 Requirement
接觸電阻 Contact Resistance	將樣品與適合的 FPC/FFC 連接，測試電壓 20mV，限電流 10mA 下的進行測定。 Mate applicable FPC/FFC and measure by dry circuit， 20mV MAX，10mA。 (JIS C5402 5.4)	30m 以下 30m MAX.
絕緣電阻 Insulation Resistance	將樣品與適合的 FPC/FFC 連接，提供相鄰端子間測試電壓 500V DC 進行絕緣電阻測試。 Mate applicable FPC/FFC and apply 500V DC between adjacent terminal or ground. (JIS C5402 5.2/MIL-STD-202 Method 302)	100M 以上 100M MIN.
耐電壓 Dielectric Strength	將樣品與適合的 FPC/FFC 連接，相鄰端子間或端子與地面間加 AC 500V (有效值) 歷時 1 分鐘下測定。 Mate applicable FPC/FFC，apply 500V AC (rms) for 1 minute between adjacent terminal or ground. (JIS C5402 5.1/MIL-STD-202 Method 301)	無擊穿現象 No Breakdown

7.2 機械性能 Mechanical Performance

項目 Item	條件 Test Condition	規格 Requirement
FPC/FFC 保持力 FPC/FFC Retention Force	將樣品與適合的FPC/FFC連接，將蓋子蓋上，以操作速度每分鐘位移 25 ± 3 mm 進行FPC/FFC 保持力測試。 Mate applicable FPC/FFC，insert the actuator，pull the FPC/FFC at a rate of 25 ± 3 mm/minute.	0.392N 以上 0.392N MIN.
端子保持力 Terminal/Housing Retention Force	端子與 Housing 組裝後，以操作速度每分鐘 25 ± 3 mm 的速度將端子拔出 Housing，進行端子保持力測試。 Apply axial pull out force at the rate of 25 ± 3 mm/minute on the terminal assembled in the housing.	0.8N 以上 0.8N MIN.

7.3 環境和其他性能 Environmental Performance and Others

項目 Item	條件 Test Condition	規格 Requirement	
蓋子往返操測試 Repeated Actuator Insertion/ Withdrawal	將蓋子與 FPC/FFC 反復連接，以 10 次/分鐘的速度操作 20 次。 Insert and withdraw actuator up to 20 cycles at the speed rate of less than 10 cycles/minute.	接觸電阻 Contact Resistance	30m 以下 30m MAX.



奕龍電子（香港）有限公司
YI LONG ELECTRONICS (HK) CO.,LTD
深圳市奕龍達科技發展有限公司

SHENZHEN YILONGDA TECHNOLOGY&DEVELOP CO.,LTD

溫升 Temperature Rise	將樣品與適合的 FPC/FFC 連接，最大容許電流通電，溫度測定。 Mate applicable FPC/FFC and measure the temperature rise of contact when the maximum AC Carrying rated. (UL 498)	溫度上升 Temperature Rise	30 以下 30 MAX.
耐振動性 Vibration	通過 DC 電流 1mA，位移相對距離 1.5mm，震動週期 10~55~10Hz，在 1 分鐘內，持續 2 小時，沿 X,Y,Z 三個方向振動做測試。 Mate connectors and subject to the following vibration conditions, for period of 2 hours in each of 3 mutually perpendicular axes, passing DC 1 mA during the test. Amplitude : 1.5mm P-P Sweep time : 10~55~10Hz in 1 minute Duration : 2 hours in each X.Y.Z. axes (MIL-STD-202 Method 201)	外觀 Appearance	無損壞 No Damage
		接觸阻抗 Contact Resistance	30m 以下 30m MAX.
		瞬間斷電 Discontinuity	1 μ sec 以下 1 μ sec MAX.
耐衝擊性 Shock	將樣品與適合的FPC/FFC連接，通過DC 1mA測試條件，沿X,Y,Z 3 軸 6 個垂直方向施與重力加速度 490m/s ² {50G}衝擊各連續測試 3 次。 Mate applicable FPC/FFC and subject to the following shock conditions. 3 times of shocks shall be applied for each 6 directions along 3 mutually perpendicular axes, passing DC 1mA current during the test. Peak value : 490m/s ² {50G} , 3 strokes in each X.Y.Z. axes. (JIS C0041/ML-STD-202 Method 213)	外觀 Appearance	無損壞 No Damage
		接觸電阻 Contact Resistance	30m 以下 30m MAX.
		瞬間斷電 Discontinuity	1 μ sec 以下 1 μ sec MAX.
耐熱性 Heat Resistance	將樣品與適合的 FPC/FFC 連接，置於環境溫度 85 ± 2 中測試，放置時間 96 小時，再回到室溫中放置 1-2 小時。 Mate applicable FPC/FFC and expose to 85 ± 2 for 96 hours . Upon completion of the exposure period, the test specimens shall be conditioned at ambient room conditions for 1 to 2 hours, after which the specified measurements shall be performed. (JIS C0021/ML-STD-202 Method 108)	外觀 Appearance	無損壞 No Damage
		接觸阻抗 Contact Resistance	30m 以下 30m MAX.
耐寒性 Cold Resistance	將樣品與適合的 FPC/FFC 連接，置於環境溫度 -40 ± 2 中測試，放置時間 96 小時，再回到室溫中放置 1-2 小時。 Mate applicable FPC/FFC and expose to -40 ± 2 for 96 hours . Upon completion of the exposure period, the test specimens shall be conditioned at ambient room conditions for 1 to 2 hours, after which the specified measurements shall be performed. (JIS C0020)	外觀 Appearance	無損壞 No Damage
		接觸阻抗 Contact Resistance	30m 以下 30m MAX.



奕龍電子（香港）有限公司
YI LONG ELECTRONICS (HK) CO.,LTD
深圳市奕龍達科技發展有限公司

SHENZHEN YILONGDA TECHNOLOGY&DEVELOP CO.,LTD

耐濕性 Humidity	將樣品與適合的 FPC/FFC 連接，置於環境溫度 60 ± 2 、相對濕度 90-95% 的空氣中測試，放置時間 96 小時，再回到室溫中放置 1-2 小時。 Mate applicable FPC/FFC and expose to 60 ± 2 , relative humidity 90 to 95% for 96 hours. Upon completion of the exposure period, the test specimens shall be conditioned at ambient room conditions for 1 to 2 hours, after which the specified measurements shall be performed. (JIS C0022/ML-STD-202 Method 103)	外觀 Appearance	無損壞 No Damage
		接觸阻抗 Contact Resistance	30m 以下 30m MAX.
		耐電壓 Dielectric Strength	無損壞 No Damage
		絕緣阻抗 Insulation Resistance	100 M 以上 100 M MIN.
冷熱衝擊 Temperature Cycling	將樣品與適合的 FPC/FFC 連接，承受 5 次冷熱衝擊迴圈後，置放於室溫下 1~2 小時。 1 次迴圈如下： a) -55 ± 3 30 分鐘 b) 85 ± 2 30 分鐘 Mate applicable FPC/FFC and subject to the following conditions for 5 cycles. Upon completion of the exposure period, the test specimens shall be conditioned at ambient room conditions for 1 to 2 hours, after which the specified measurements shall be performed. 1 cycle: a) -55 ± 3 30minutes b) 85 ± 2 30minutes (JIS C0025)	外觀 Appearance	無損壞 No Damage
		接觸阻抗 Contact Resistance	30m 以下 30m MAX.
耐鹽霧性 Salt Spray	將樣品與適合的 FPC/FFC 連接，使用 $5 \pm 1\%$ 的鹽水噴霧，測試溫度 35 ± 2 ，測試時間 48 ± 4 小時，測試室溫下清水沖洗，再室溫乾燥。 Mate applicable FPC/FFC and expose to the following salt mist conditions. Upon completion of the exposure period, salt deposits shall be removed by a gentle wash of dip in running water, after which the specified measurements shall be performed. NaCl solution Concentration: $5 \pm 1\%$ Spray time: 48 ± 4 hours Ambient temperature: 35 ± 2 (JIS C0022/ML-STD-202 Method 101)	外觀 Appearance	無損壞、腐蝕 No Damage
		接觸阻抗 Contact Resistance	30m 以下 30m MAX.
二氧化硫（氣體） SO ₂ Gas	將樣品與適合的 FPC/FFC 連接，將其置放於 50 ± 5 ppm 濃度的二氧化硫（氣體）中，測試溫度 40 ± 2 ，測試時間 24 小時。 Mate applicable FPC/FFC and expose them to the following SO ₂ gas atmosphere. Temperature: 40 ± 2 Gas Density: 50 ± 5 ppm Duration: 24 hours	外觀 Appearance	無損壞、腐蝕 No Damage
		接觸電阻 Contact Resistance	30m 以下 30m MAX.



奕龍電子（香港）有限公司
YI LONG ELECTRONICS (HK) CO.,LTD
深圳市奕龍達科技發展有限公司

SHENZHEN YILONGDA TECHNOLOGY&DEVELOP CO.,LTD

耐氨性（氣體） NH ₃ Gas	暴露來自濃度為 28%的阿摩尼亞之蒸發氣體NH ₃ 中，測試時間 40 分鐘。 40 minutes exposure to NH ₃ gas evaporating from 28% Ammonia solution.	外觀 Appearance	無損壞 No Damage
		接觸電阻 Contact Resistance	30m 以下 30m MAX.
焊錫性 Solderability	錫溫 245 ± 5 ，將導電端子侵入錫融液面至 Housing 距離錫面 0.1mm 位置，歷時 3 ± 0.5 秒。 Tip of solder tails and fitting nails in to the molten solder (held at 245 ± 5) up tp 0.1mm from the bottom of the housing for 3 ± 0.5 seconds.	沾敷性 Solder Wetting	沾敷面積 95% 以上，並不得有漏焊針孔 95% of immersed area must show no voids, pin holes
耐焊接熱 Resistance to Soldering heat	使用紅外線回流焊時請查考回流焊曲線圖。 When reflowing.. Refer to reflowing map. 使用烙鐵手焊須符合下述焊錫條件： Soldering iron method: 0.2mm from terminal tip and fitting nail tip Soldering time : 5 seconds Max Solder temperature: 370 ~ 400	外觀 Appearance	無損壞、變形 No Damage



【8】紅外線回流焊溫度曲線 INFRARED REFLOW CON DITION

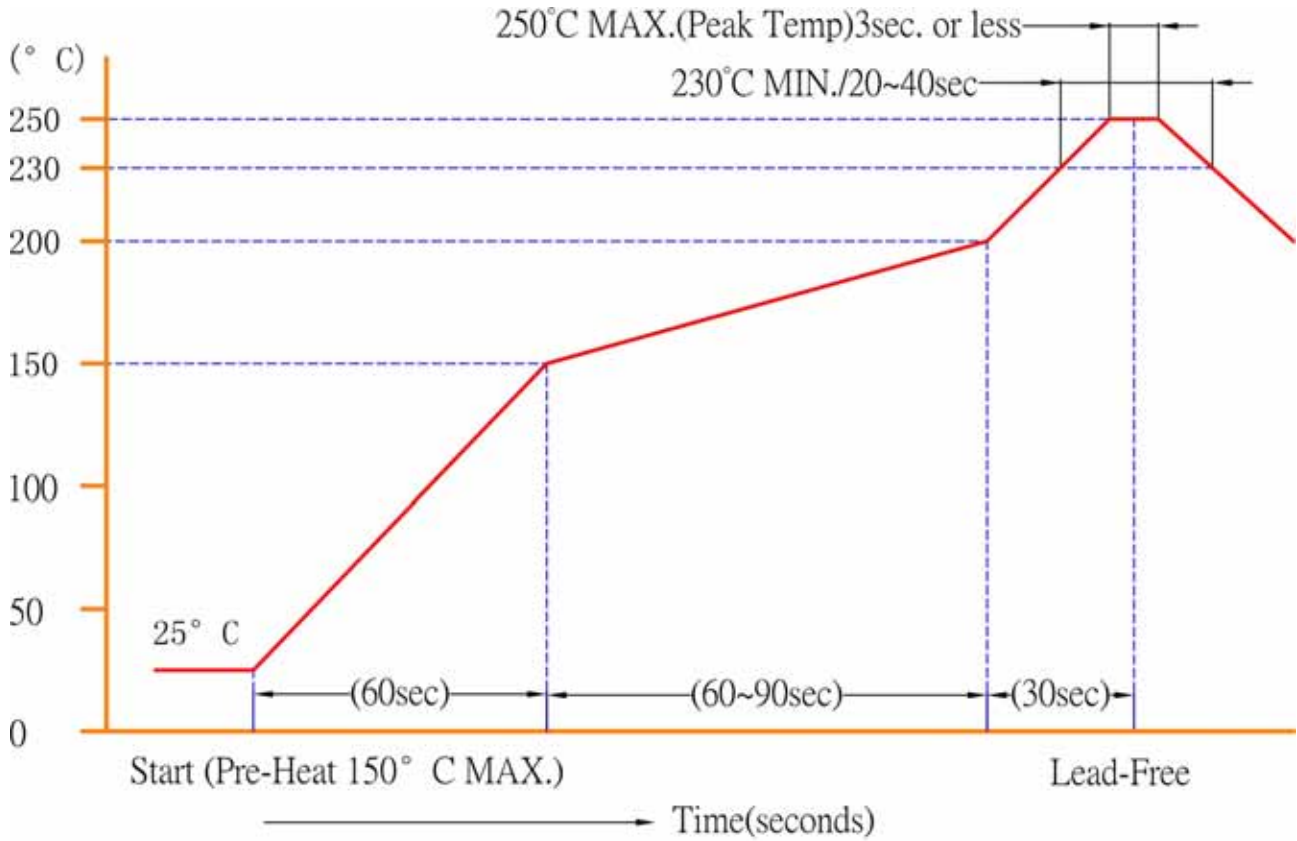

溫度條件 TEMPERATURE CONDITION GRAPH

(基板表面溫度) (TEMPERATURE ON BOARD PATTERN SIDE)

Test Report

No. : CE/2007/B7991 Date : 2007/12/05 Page : 1 of 6

DSM ENGINEERING PLASTICS



The following sample(s) was/were submitted and identified by/on behalf of the client as :

Sample Description : STANYL TS250F8 NATURAL
Sample Receiving Date : 2007/11/29
Testing Period : 2007/11/29 TO 2007/12/05

=====
Test Result(s) : Please refer to next page(s).



Chenyu Kung / Operation Manager
Signed for and on behalf of
SGS TAIWAN LTD.
Chemical Laboratory – Taipei

Test Report

No. : CE/2007/B7991 Date : 2007/12/05 Page : 2 of 6

DSM ENGINEERING PLASTICS



Test Result(s)

PART NAME NO.1 : CREAM PLASTIC PELLETS

Test Item (s):	Unit	Method	MDL	Result
				No.1
Cadmium (Cd)	mg/kg	With reference to IEC 62321, Ed.1 111/54/CDV. Determination of Cadmium by ICP-AES.	2	n.d.
Lead (Pb)	mg/kg	With reference to IEC 62321, Ed.1 111/54/CDV. Determination of Lead by ICP-AES.	2	9
Mercury (Hg)	mg/kg	With reference to IEC 62321, Ed.1 111/54/CDV. Determination of Mercury by ICP-AES.	2	n.d.
Hexavalent Chromium Cr(VI) by alkaline extraction	mg/kg	With reference to IEC 62321, Ed.1 111/54/CDV. Determination of Hexavalent Chromium for non-metallic samples by UV/Vis Spectrometry.	2	n.d.
PVC	%	Analysis was performed by FTIR and Pyrolyzer-GC/MS.	1	Negative
Sum of PBBs	mg/kg	With reference to IEC 62321, Ed.1 111/54/CDV. Determination of PBB and PBDE by GC/MS.	-	n.d.
Monobromobiphenyl			5	n.d.
Dibromobiphenyl			5	n.d.
Tribromobiphenyl			5	n.d.
Tetrabromobiphenyl			5	n.d.
Pentabromobiphenyl			5	n.d.
Hexabromobiphenyl			5	n.d.
Heptabromobiphenyl			5	n.d.
Octabromobiphenyl			5	n.d.
Nonabromobiphenyl			5	n.d.
Decabromobiphenyl			5	n.d.

Test Report

No. : CE/2007/B7991 Date : 2007/12/05 Page : 3 of 6

DSM ENGINEERING PLASTICS



Test Item (s):	Unit	Method	MDL	Result
				No.1
Sum of PBDEs (Mono to Nona) (Note 4)	mg/kg	With reference to IEC 62321, Ed.1 111/54/CDV. Determination of PBB and PBDE by GC/MS.	-	n.d.
Monobromobiphenyl ether			5	n.d.
Dibromobiphenyl ether			5	n.d.
Tribromobiphenyl ether			5	n.d.
Tetrabromobiphenyl ether			5	n.d.
Pentabromobiphenyl ether			5	n.d.
Hexabromobiphenyl ether			5	n.d.
Heptabromobiphenyl ether			5	n.d.
Octabromobiphenyl ether			5	n.d.
Nonabromobiphenyl ether			5	n.d.
Decabromobiphenyl ether			5	n.d.
Sum of PBDEs (Mono to Deca)			-	n.d.

- Note :
1. mg/kg = ppm
 2. n.d. = Not Detected
 3. MDL = Method Detection Limit
 4. According to 2005/717/EC DecaBDE is exempt.
 5. " - " = Not Regulated
 6. Negative = "< 1.0 %", Positive = "> 1.0 %"



- 1) These samples were dissolved totally by pre-conditioning method according to below flow chart.
(Cr⁶⁺ test method excluded)
- 2) Name of the person who made measurement: Troy Chang
- 3) Name of the person in charge of measurement: Chenyu Kung

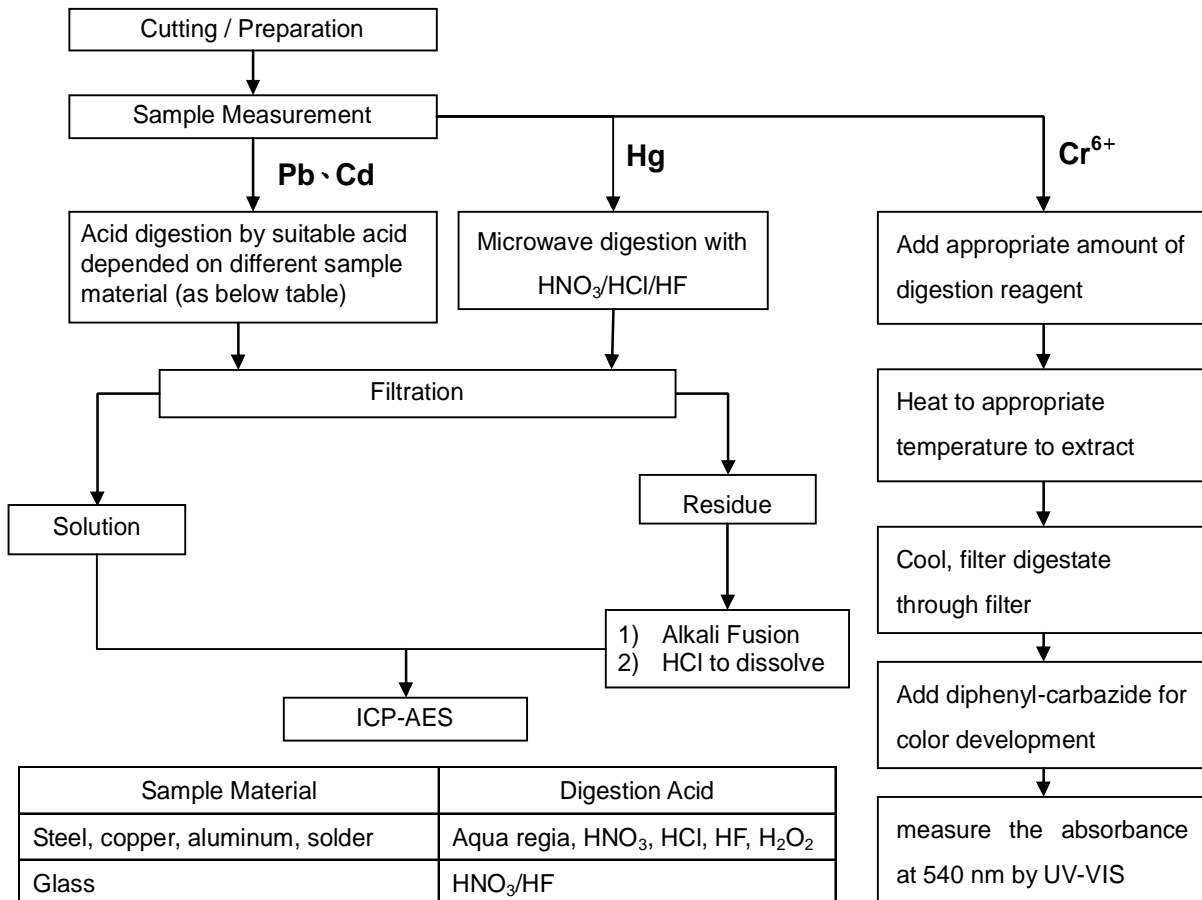

Sample Material	Digestion Acid
Steel, copper, aluminum, solder	Aqua regia, HNO ₃ , HCl, HF, H ₂ O ₂
Glass	HNO ₃ /HF
Gold, platinum, palladium, ceramic	Aqua regia
Silver	HNO ₃
Plastic	H ₂ SO ₄ , H ₂ O ₂ , HNO ₃ , HCl
Others	Any acid to total digestion



PBB/PBDE analytical FLOW CHART

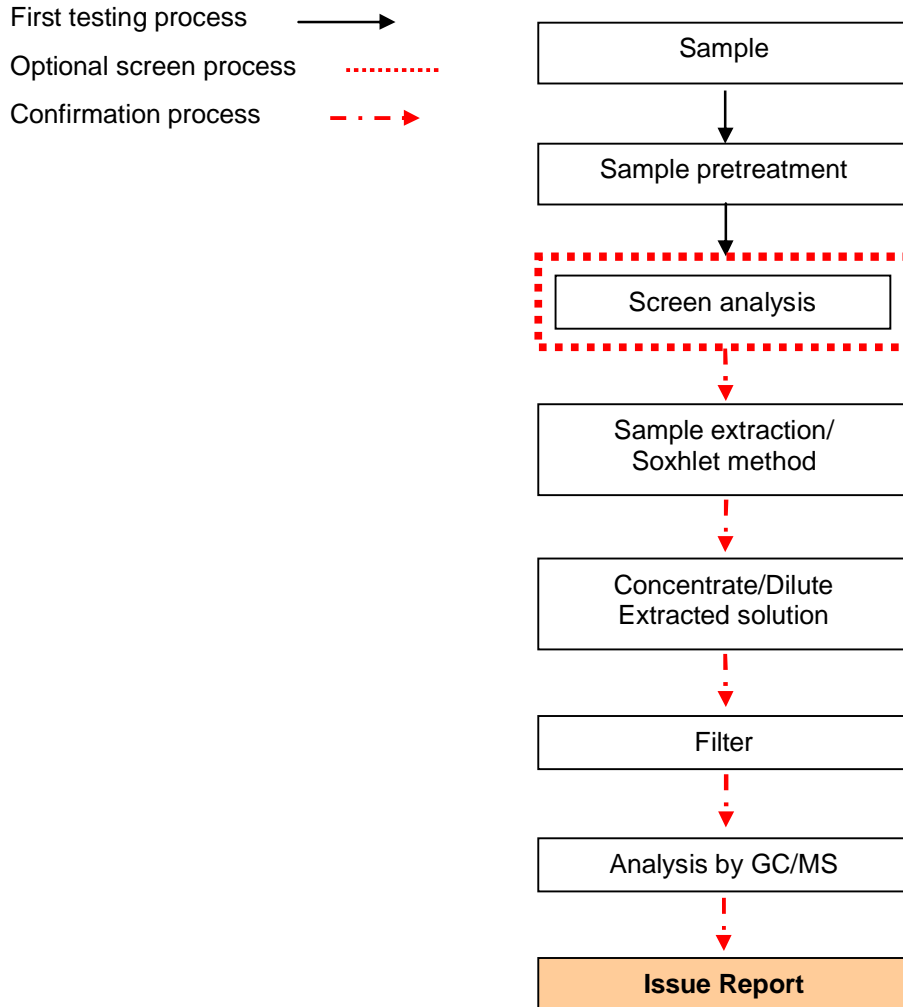

Test Report

No. : CE/2007/B7991 Date : 2007/12/05 Page : 6 of 6

DSM ENGINEERING PLASTICS



** End of Report **

測試報告

號碼 : CE/2007/65251 日期 : 2007/07/02 頁數 : 1 of 6

新泰伸科技股份有限公司
HTS TECHNOLOGY CO., LTD.
桃園縣楊梅鎮民隆路8號



8, MING LUNG RD., YANG MEI JEN, TAO YUAN, TAIWAN 326, R. O. C.

以下測試樣品係由客戶送樣，且由客戶聲稱並經客戶確認如下(The following sample(s) was/were submitted and identified by/on behalf of the client as) :

樣品名稱 : 磷青銅
Sample Description : PHOSPHOR BRONZE
收件日期(Sample Receiving Date) : 2007/06/25
測試期間(Testing Period) : 2007/06/25 TO 2007/07/02

=====

測試需求 / Test Requested : 參照 RoHS 2002/95/EC 及其修定指令要求. / In accordance with the RoHS Directive 2002/95/EC, and its amendment directives.

測試方法 / Test Method : 參考 IEC 62321, Ed. 1 111/54/CDV 方法檢測. / With reference to IEC 62321, Ed.1 111/54/CDV. Procedures for the Determination of Levels of Regulated Substances in Electrotechnical Products.

(1) 用感應耦合電漿原子發射光譜儀檢測鎘含量. / Determination of Cadmium by ICP-AES.

(2) 用感應耦合電漿原子發射光譜儀檢測鉛含量. / Determination of Lead by ICP-AES.

(3) 用感應耦合電漿原子發射光譜儀檢測汞含量. / Determination of Mercury by ICP-AES.

(4) 針對金屬材質之樣品，用 Spot test / Colorimetric 方法檢測六價鉻含量. / Determination of Hexavalent Chromium for metallic samples by Spot test / Colorimetric Method.

(5) 以氣相層析儀/質譜儀檢測多溴聯苯和多溴聯苯醚含量. / Determination of PBB and PBDE by GC/MS.

測試結果 / Test Result(s) : 請見下一頁.

結論 / Conclusion : 根據客戶所提供樣品的測試結果，符合 RoHS(2002/95/EC) 及其修定指令之要求. / Based on the performed tests on submitted samples, the test results are **compliant with** the limits of RoHS Directive 2002/95/EC and its subsequent amendments.

Daniel Yeh, M.R. / Operation Manager
Signed for and on behalf of
SGS TAIWAN LTD.
Chemical Laboratory - Taipei

測試報告

號碼：CE/2007/65251

日期：2007/07/02

頁數：2 of 6

新泰伸科技股份有限公司



HTS TECHNOLOGY CO., LTD.

桃園縣楊梅鎮民隆路8號

8, MING LUNG RD., YANG MEI JEN, TAO YUAN, TAIWAN 326, R. O. C.

測試結果 (單位: mg/kg) / Test Result(s)

測試項目 / Test Item (s):	測試方法 Method (Refer to)	結果 / Result	方法偵測 極限值 (MDL)	RoHS 限值
		No.1		
鎘 / Cadmium (Cd)	(1)	n.d.	2	100
鉛 / Lead (Pb)	(2)	25	2	1000
汞 / Mercury (Hg)	(3)	n.d.	2	1000
六價鉻 / Hexavalent Chromium Cr(VI) by Spot test / boiling water extraction	(4)	Negative	See Note 5	#
多溴聯苯總和 / Sum of PBBs	(5)	n.d.	-	1000
一溴聯苯 / Monobromobiphenyl		n.d.	5	-
二溴聯苯 / Dibromobiphenyl		n.d.	5	-
三溴聯苯 / Tribromobiphenyl		n.d.	5	-
四溴聯苯 / Tetrabromobiphenyl		n.d.	5	-
五溴聯苯 / Pentabromobiphenyl		n.d.	5	-
六溴聯苯 / Hexabromobiphenyl		n.d.	5	-
七溴聯苯 / Heptabromobiphenyl		n.d.	5	-
八溴聯苯 / Octabromobiphenyl		n.d.	5	-
九溴聯苯 / Nonabromobiphenyl		n.d.	5	-
十溴聯苯 / Decabromobiphenyl		n.d.	5	-
多溴聯苯醚總和 (一至九溴) / Sum of PBDEs (Mono to Nona) (Note 4)		n.d.	-	1000
一溴聯苯醚 / Monobromobiphenyl ether		n.d.	5	-
二溴聯苯醚 / Dibromobiphenyl ether		n.d.	5	-
三溴聯苯醚 / Tribromobiphenyl ether		n.d.	5	-
四溴聯苯醚 / Tetrabromobiphenyl ether		n.d.	5	-
五溴聯苯醚 / Pentabromobiphenyl ether		n.d.	5	-
六溴聯苯醚 / Hexabromobiphenyl ether		n.d.	5	-
七溴聯苯醚 / Heptabromobiphenyl ether		n.d.	5	-
八溴聯苯醚 / Octabromobiphenyl ether		n.d.	5	-
九溴聯苯醚 / Nonabromobiphenyl ether	n.d.	5	-	
十溴聯苯醚 / Decabromobiphenyl ether	n.d.	5	-	
多溴聯苯醚總和 (一至十溴) / Sum of PBDEs (Mono to Deca)	n.d.	-	-	

測試部位描述 / TEST PART DESCRIPTION:

NO.1 : 銅色金屬片 / COPPER COLORED METAL SHEET

測試報告

號碼：CE/2007/65251

日期：2007/07/02

頁數：3 of 6

新泰伸科技股份有限公司
HTS TECHNOLOGY CO., LTD.
桃園縣楊梅鎮民隆路8號
8, MING LUNG RD., YANG MEI JEN, TAO YUAN, TAIWAN 326, R. O. C.



Note: 1. mg/kg = ppm

2. n.d. = Not Detected / 未檢出

3. MDL = Method Detection Limit / 方法偵測極限值

4. According to 2005/717/EC DecaBDE is exempt.

根據2005年10月13日歐盟會議公佈2005/717/EC，修訂2002/95/EC內容，通過解除
高分子材質中十溴聯苯醚之使用限制。

5. Spot-test:

Negative = Absence of Cr(VI) coating / surface layer,

Positive = Presence of Cr(VI) coating / surface layer;

(The tested sample should be further verified by boiling-water-extraction method if the
spot test result cannot be confirmed.)

Negative=鍍層中偵測不到六價鉻，Positive=鍍層中偵測到六價鉻；

當該測項無法確認時，測試樣品可藉由boiling-water-extraction測試方法進一步確認

Boiling-water-extraction:

Negative = Absence of Cr(VI) coating / surface layer,

Positive = Presence of Cr(VI) coating / surface layer; the detected concentration in

boiling-water-extraction solution is equal or greater than 0.02 mg/kg with 50 cm²
sample surface area.

Negative=鍍層中偵測不到六價鉻，Positive=鍍層中偵測到六價鉻；

該濃度溶液 ≥ 0.02 mg/kg with 50 cm² (sample surface area)

6. # = Positive indicates the presence of Cr(VI) on the tested areas
and result be regarded as not comply with RoHS requirement.

Positive表示測試區域之六價鉻不符合RoHS要求

Negative indicates the absence of Cr(VI) on the tested areas and result be regarded
as comply with RoHS requirement. / Negative表示測試區域之六價鉻符合RoHS要求

7. "-" = Not Regulated / 無規格值

測試報告

號碼：CE/2007/65251

日期：2007/07/02

頁數：4 of 6

新泰伸科技股份有限公司
HTS TECHNOLOGY CO., LTD.
桃園縣楊梅鎮民隆路8號
8, MING LUNG RD., YANG MEI JEN, TAO YUAN, TAIWAN 326, R. O. C.



- 1) 根據以下的流程圖之條件，樣品已完全溶解。(六價鉻測試方法除外) / These samples were dissolved totally by pre-conditioning method according to below flow chart. (Cr⁶⁺ test method excluded)
- 2) 測試人員：張啓興 / Name of the person who made measurement: Troy Chang
- 3) 測試負責人：葉禮源 / Name of the person in charge of measurement: Daniel Yeh

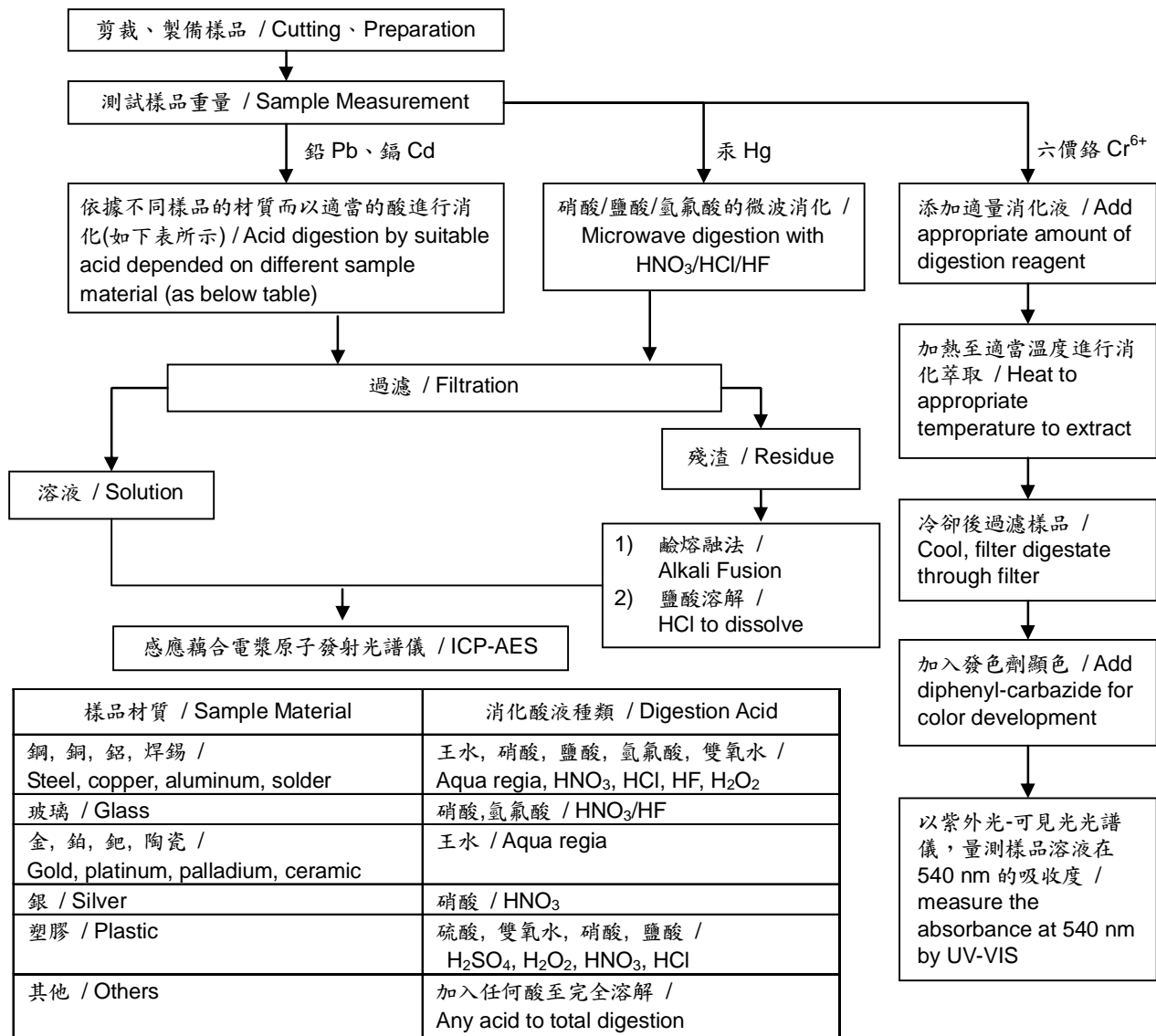

測試報告

號碼：CE/2007/65251

日期：2007/07/02

頁數：5 of 6

新泰伸科技股份有限公司
HTS TECHNOLOGY CO., LTD.
桃園縣楊梅鎮民隆路8號



8, MING LUNG RD., YANG MEI JEN, TAO YUAN, TAIWAN 326, R. O. C.

多溴聯苯/多溴聯苯醚分析流程圖 / PBB/PBDE analytical FLOW CHART

初次測試程序 / First testing process ———→
 選擇性篩檢程序 / Optional screen process
 確認程序 / Confirmation process - - - ->

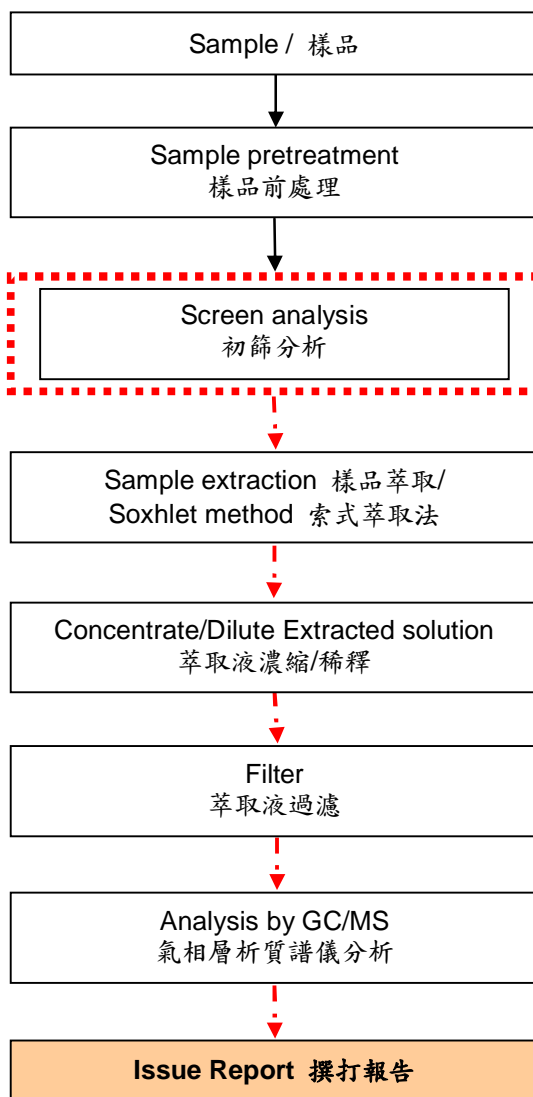

測試報告

號碼：CE/2007/65251

日期：2007/07/02

頁數：6 of 6

新泰伸科技股份有限公司
HTS TECHNOLOGY CO., LTD.

桃園縣楊梅鎮民隆路8號

8, MING LUNG RD., YANG MEI JEN, TAO YUAN, TAIWAN 326, R. O. C.



** 報告結尾 **

Test Report

No. : CE/2007/C1120 Date : 2007/12/12 Page : 1 of 7

KURARAY CO., LTD.
OTE CENTER BLDG., 1-1-3, OTE MACHI, CHI-YODA KU, TOKYO, JAPAN



The following sample(s) was/were submitted and identified by/on behalf of the client as :

Sample Description : NEW HEAT-RESISTANT POLYAMIDE RESIN
Style/Item No. : PA9T G2330-BK
Sample Receiving Date : 2007/12/05
Testing Period : 2007/12/05 TO 2007/12/12

=====
Test Result(s) : Please refer to next page(s).



Chenyu Kung / Operation Manager
Signed for and on behalf of
SGS TAIWAN LTD.
Chemical Laboratory – Taipei

Test Report

No. : CE/2007/C1120 Date : 2007/12/12 Page : 2 of 7

KURARAY CO., LTD.
 OTE CENTER BLDG., 1-1-3, OTE MACHI, CHI-YODA KU, TOKYO, JAPAN



Test Result(s)

PART NAME NO.1 : BLACK PLASTIC PELLETS

Test Item (s):	Unit	Method	MDL	Result
				No.1
Cadmium (Cd)	mg/kg	With reference to IEC 62321, Ed.1 111/54/CDV. Determination of Cadmium by ICP-AES.	2	n.d.
Lead (Pb)	mg/kg	With reference to IEC 62321, Ed.1 111/54/CDV. Determination of Lead by ICP-AES.	2	7
Mercury (Hg)	mg/kg	With reference to IEC 62321, Ed.1 111/54/CDV. Determination of Mercury by ICP-AES.	2	n.d.
Hexavalent Chromium Cr(VI) by alkaline extraction	mg/kg	With reference to IEC 62321, Ed.1 111/54/CDV. Determination of Hexavalent Chromium for non-metallic samples by UV/Vis Spectrometry.	2	n.d.
Halogen	---	With reference to BS EN 14582. Analysis was performed by IC method for F , Cl , Br, I content.	---	---
Halogen-Fluorine (F) (CAS No.: 007782-41-4)	mg/kg	With reference to BS EN 14582. Analysis was performed by IC method for Fluorine content.	50	3260
Halogen-Chlorine (Cl) (CAS No.: 007782-50-5)	mg/kg	With reference to BS EN 14582. Analysis was performed by IC method for Chlorine content.	50	n.d.
Halogen-Bromine (Br) (CAS No.: 007726-95-6)	mg/kg	With reference to BS EN 14582. Analysis was performed by IC method for Bromine content.	50	134000
Halogen-Iodine (I) (CAS No.: 007553-56-2)	mg/kg	With reference to BS EN 14582. Analysis was performed by IC method for Iodine content.	50	n.d.

Test Report

No. : CE/2007/C1120 Date : 2007/12/12 Page : 3 of 7

KURARAY CO., LTD.

OTE CENTER BLDG., 1-1-3, OTE MACHI, CHI-YODA KU, TOKYO, JAPAN



Test Item (s):	Unit	Method	MDL	Result
				No.1
Sum of PBBs	mg/kg	With reference to IEC 62321, Ed.1 111/54/CDV. Determination of PBB and PBDE by GC/MS.	-	n.d.
Monobromobiphenyl			5	n.d.
Dibromobiphenyl			5	n.d.
Tribromobiphenyl			5	n.d.
Tetrabromobiphenyl			5	n.d.
Pentabromobiphenyl			5	n.d.
Hexabromobiphenyl			5	n.d.
Heptabromobiphenyl			5	n.d.
Octabromobiphenyl			5	n.d.
Nonabromobiphenyl			5	n.d.
Decabromobiphenyl			5	n.d.
Sum of PBDEs (Mono to Nona) (Note 4)			-	n.d.
Monobromobiphenyl ether			5	n.d.
Dibromobiphenyl ether			5	n.d.
Tribromobiphenyl ether			5	n.d.
Tetrabromobiphenyl ether			5	n.d.
Pentabromobiphenyl ether			5	n.d.
Hexabromobiphenyl ether			5	n.d.
Heptabromobiphenyl ether			5	n.d.
Octabromobiphenyl ether			5	n.d.
Nonabromobiphenyl ether			5	n.d.
Decabromobiphenyl ether			5	n.d.
Sum of PBDEs (Mono to Deca)			-	n.d.

- Note :
1. mg/kg = ppm
 2. n.d. = Not Detected
 3. MDL = Method Detection Limit
 4. According to 2005/717/EC DecaBDE is exempt.
 5. "---" = Not Conducted
 6. "- " = Not Regulated

Test Report

No. : CE/2007/C1120 Date : 2007/12/12 Page : 4 of 7

KURARAY CO., LTD.

OTE CENTER BLDG., 1-1-3, OTE MACHI, CHI-YODA KU, TOKYO, JAPAN



1) These samples were dissolved totally by pre-conditioning method according to below flow chart.
(Cr⁶⁺ test method excluded)

2) Name of the person who made measurement: Troy Chang

3) Name of the person in charge of measurement: Chenyu Kung

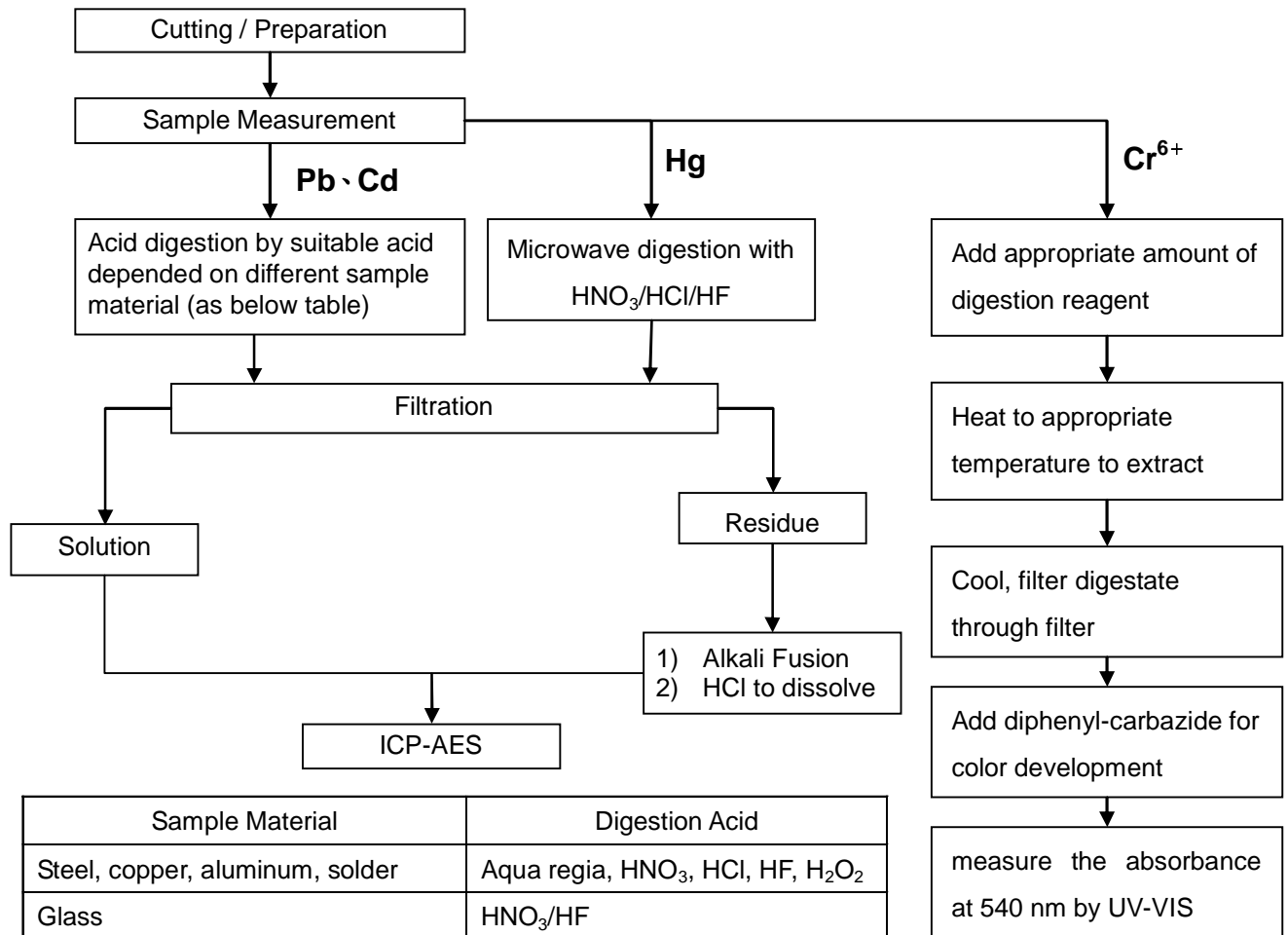

Sample Material	Digestion Acid
Steel, copper, aluminum, solder	Aqua regia, HNO ₃ , HCl, HF, H ₂ O ₂
Glass	HNO ₃ /HF
Gold, platinum, palladium, ceramic	Aqua regia
Silver	HNO ₃
Plastic	H ₂ SO ₄ , H ₂ O ₂ , HNO ₃ , HCl
Others	Any acid to total digestion



PBB/PBDE analytical FLOW CHART

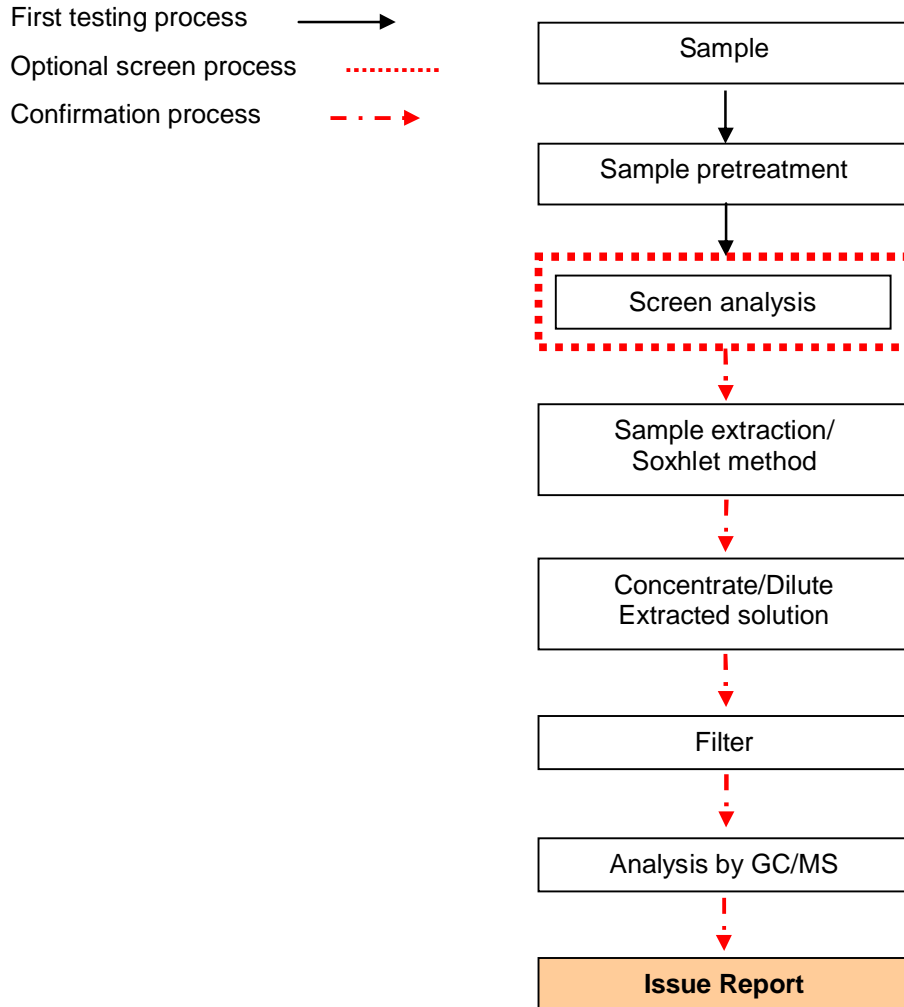

Test Report

No. : CE/2007/C1120 Date : 2007/12/12 Page : 6 of 7

KURARAY CO., LTD.
OTE CENTER BLDG., 1-1-3, OTE MACHI, CHI-YODA KU, TOKYO, JAPAN



Analytical flow chart of halogen content

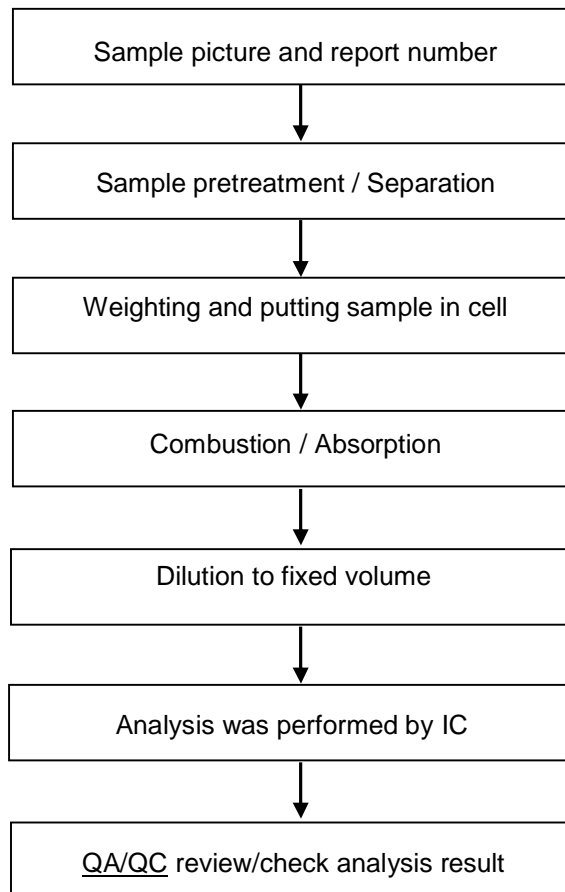

Test Report

No. : CE/2007/C1120 Date : 2007/12/12 Page : 7 of 7

KURARAY CO., LTD.

OTE CENTER BLDG., 1-1-3, OTE MACHI, CHI-YODA KU, TOKYO, JAPAN



** End of Report **