

0.3mm Contact Pitch, 1mm above the board, Flexible Printed Circuit ZIF Connectors

FH26 Series

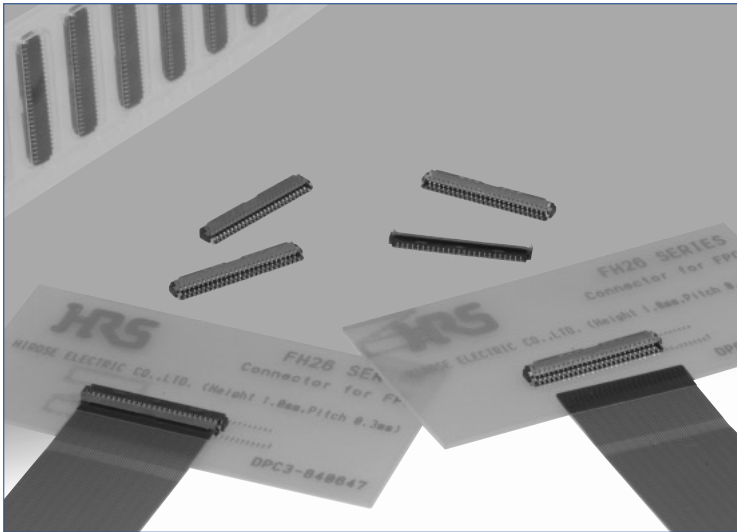

●Space saving(51 pos. shown)

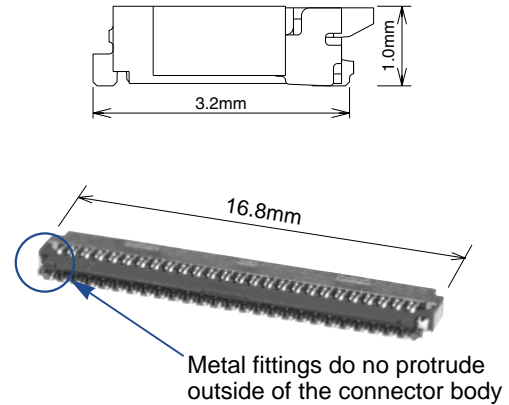

■Features

1. Extremely light weight

The typical version, with all 51 contacts loaded, weights only 0.1 grams.

2. Easy solderability on the PC board

The soldering leads are on 0.6 mm pitch, exiting on front and back of the connector.

3. Conductive traces on the PCB can run under the connector

No exposed contacts on the bottom of the connector.

4. Easy FPC insertion and reliable electrical connection

Proven Flip LockR actuator allows easy insertion of FPC. Tactile sensation when fully closed confirms complete electrical and mechanical connection.

5. Accepts standard thickness FPC

0.2mm thick standard Flexible Printed Circuit board can be used.

This is the only ultra-low profile ZIF connector allowing the use of standard FPC.

6. Board placement with automatic equipment

Flat top surface and packaging on the tape-and-reel allows use of vacuum nozzles.

Standard reel contains 5,000 connectors.

●Can be mounted over conductive traces.

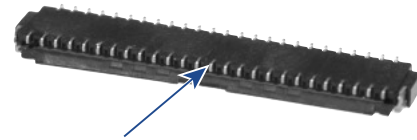

No exposed contacts on the bottom of the connector

●Operation

- (1) Actuator open
- (2) Insert FPC

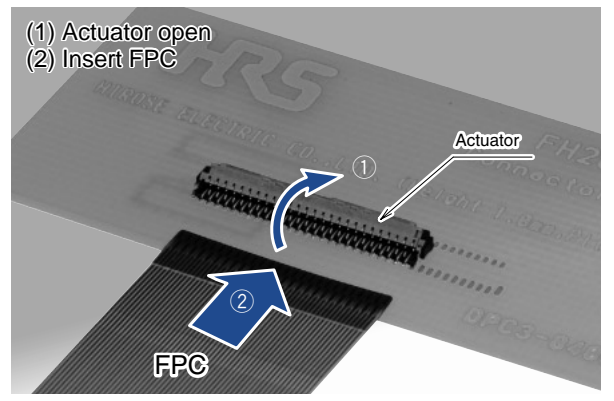

- (3) Close the actuator
- (4) FPC connected

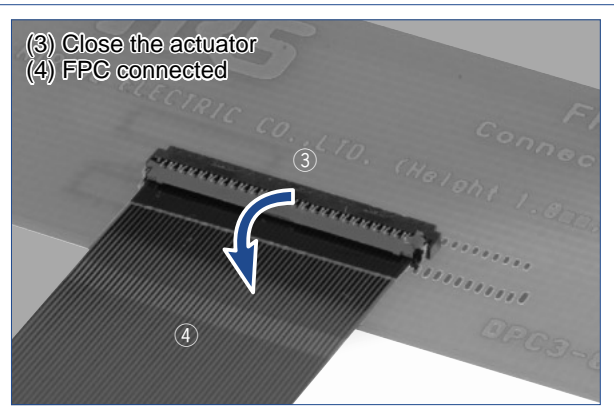

■ Specifications

Rating	Current rating 0.2A DC Voltage rating 30V AC	Operating temperature range -55 °C to +85°C (Note 1) Operating humidity range Relative humidity 90% max. (No condensation)	Storage temperature range -10°C to +50°C (Note 2) Storage humidity range Relative humidity 90% max.
--------	---	---	--

Recommended FPC :	Thickness: = 0.2±0.03mm tin-lead plated (Note 3)
-------------------	--

Item	Specification	Conditions
1. Insulation resistance	50 M ohms min.	100 V DC
2. Withstanding voltage	No flashover or insulation breakdown.	90 V AC /one minute
3. Contact resistance	100 m ohms max. * Including FPC conductor resistance	1 mA
4. Durability (Insertion/ withdrawal)	Contact resistance: 100 m ohms max. No damage, cracks, or parts dislocation.	10 cycles
5. Vibration	No electrical discontinuity of 1μs or more. Contact resistance: 100 m ohms max. No damage, cracks, or parts dislocation.	Frequency: 10 to 55 Hz, single amplitude of 0.75 mm, 10 cycles, 3 directions.
6. Shock	No electrical discontinuity of 1μs. min. Contact resistance: 100 m ohms max. No damage, cracks, or parts dislocation.	Acceleration of 981 m/s ² , 6 ms duration, sine half-wave waveform, 3 cycles in each of the 3 axis
7. Humidity (Steady state)	Contact resistance: 100 m ohms max. Insulation resistance: 50 M ohms min. No affect on appearance or performance.	96 hours at temperature of 40±2°C and humidity of 90% to 95%.
8. Temperature cycle	Contact resistance: 100 m ohms max. Insulation resistance: 50 M ohms min. No damage, cracks, or parts looseness.	Temperature: -55 °C→+15°C to +35°C→+85°C→+15°C to +35°C Time: 30 → 2 to 3 → 30 → 2 to 3 (Minutes) 5 cycles
9. Resistance to soldering heat	No deformation of components affecting performance.	Reflow: At the recommended temperature profile Manual soldering: 350°C +/-10°C for 5±1 seconds

Note 1: Includes temperature rise caused by current flow.

Note 2: The term "storage" refers to products stored for long period of time prior to mounting and use. Operating Temperature Range and Humidity range covers non- conducting condition of installed connectors in storage, shipment or during transportation.

Note 3: When FPC is gold plated, the connector contacts must be also gold plated: Specify the (05) plating code.

■ Materials

Part	Material	Finish	Remarks
Insulator	Polyamide, LCP	Color: Black	UL94V-0
Actuator	PA	Color: Dark brown	
Contacts	Phosphor bronze	Tin-lead plated (Note 3)	—
Metal fitting		Tin plated (Lead free)	—

■ Ordering information

FH26 - 51S - 0.3 SHW (05)

①

②

③

④

⑤

① Series name: FH26	④ Terminal type: SHW(SMT horizontal mounting)
② No. of contacts: 13, 21, 23, 25, 27, 33, 35, 39, 41, 45, 51, 57, 71	⑤ Plating specifications Blank: Tin-lead plated (05) : Gold flash plated
③ Contact pitch: 0.3mm	

Connector Dimensions

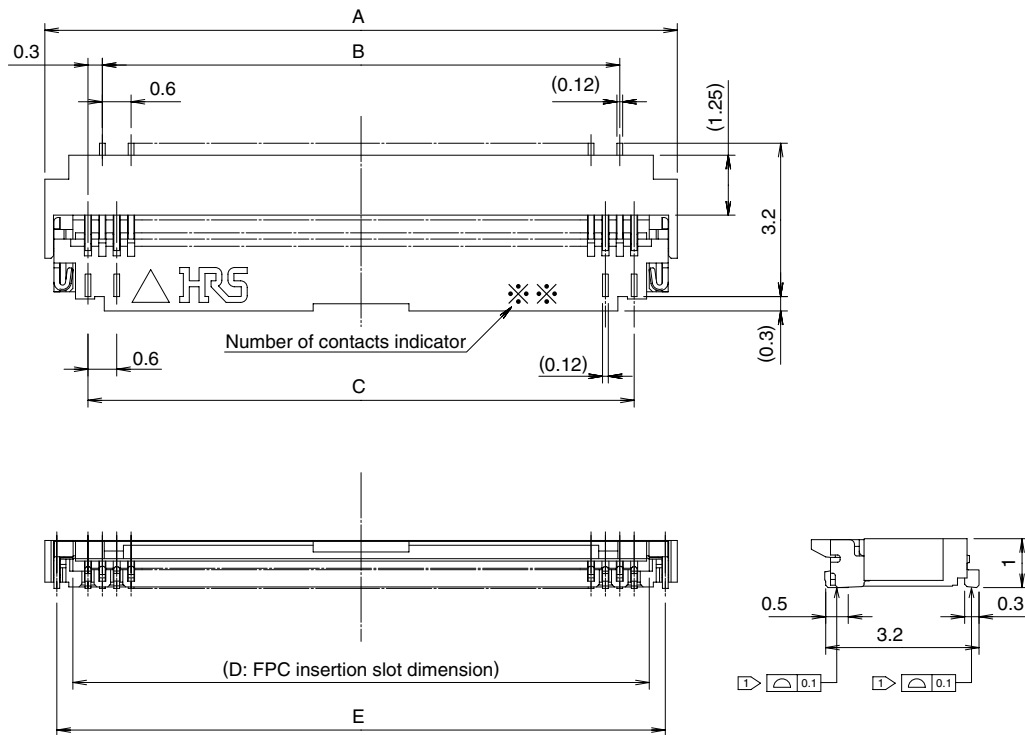

- Notes
- 1 The coplanarity of each terminal lead within specified dimension is ± 0.1 mm.
 - 2 Packaged on tape and reel only. Check packaging specification.

All dimensions: mm

Part Number	CL No.	Number of Contacts	A	B	C	D	E
FH26-13S-0.3SHW	CL580-0209-3	13	5.4	3.0	3.6	4.23	4.9
FH26-21S-0.3SHW	CL580-0207-8	21	7.8	5.4	6.0	6.63	7.3
FH26-23S-0.3SHW	CL580-0203-7	23	8.4	6.0	6.6	7.23	7.9
FH26-25S-0.3SHW	CL580-0208-0	25	9.0	6.6	7.2	7.83	8.5
FH26-27S-0.3SHW	CL580-0204-0	27	9.6	7.2	7.8	8.43	9.1
FH26-33S-0.3SHW	CL580-0210-2	33	11.4	9.0	9.6	10.23	10.9
FH26-35S-0.3SHW	CL580-0205-2	35	12.0	9.6	10.2	10.83	11.5
FH26-39S-0.3SHW	CL580-0201-1	39	13.2	10.8	11.4	12.03	12.7
FH26-41S-0.3SHW	CL580-0206-5	41	13.8	11.4	12.0	12.63	13.3
FH26-45S-0.3SHW	CL580-0211-5	45	15.0	12.6	13.2	13.83	14.5
FH26-51S-0.3SHW	CL580-0200-9	51	16.8	14.4	15.0	15.63	16.3
FH26-57S-0.3SHW	CL580-0212-8	57	18.6	16.2	16.8	17.43	18.1
FH26-71S-0.3SHW	CL580-0202-4	71	22.8	20.4	21.0	21.63	22.3

Embossed tape reel packaging (5,000 pieces/reel).
Order by number of reels.

◆ Recommended PCB mounting pattern and metal mask dimensions

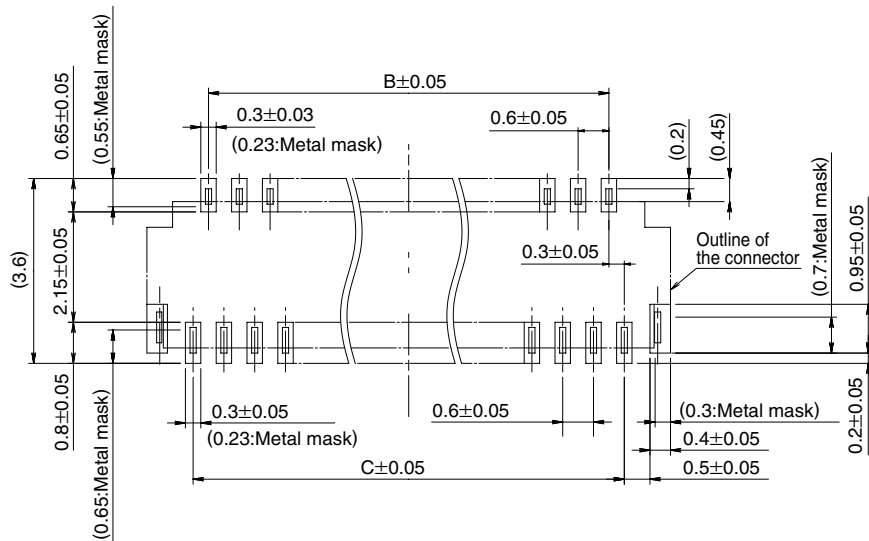

◆ Recommended FPC Dimensions

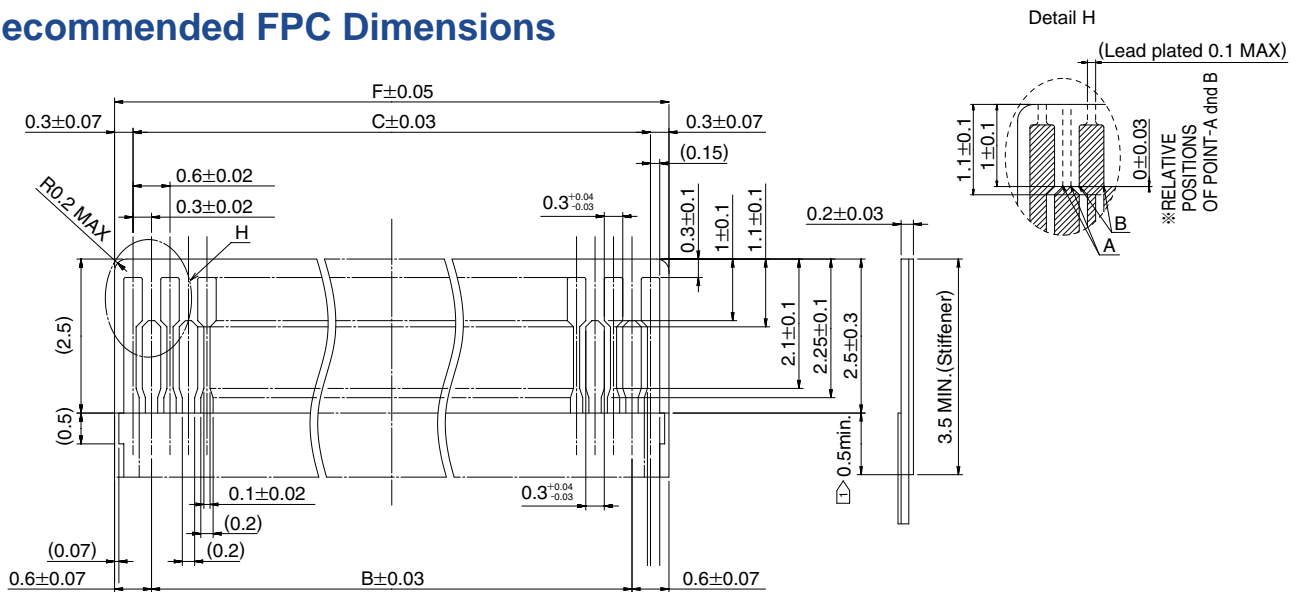

1) Overlap between covering film layer and stiffener.

All dimensions: mm

Part Number	CL No.	Number of Contacts	B	C	F
FH26-13S-0.3SHW	CL580-0209-3	13	3.0	3.6	4.2
FH26-21S-0.3SHW	CL580-0207-8	21	5.4	6.0	6.6
FH26-23S-0.3SHW	CL580-0203-7	23	6.0	6.6	7.2
FH26-25S-0.3SHW	CL580-0208-0	25	6.6	7.2	7.8
FH26-27S-0.3SHW	CL580-0204-0	27	7.2	7.8	8.4
FH26-33S-0.3SHW	CL580-0210-2	33	9.0	9.6	10.2
FH26-35S-0.3SHW	CL580-0205-2	35	9.6	10.2	10.8
FH26-39S-0.3SHW	CL580-0201-1	39	10.8	11.4	12.0
FH26-41S-0.3SHW	CL580-0206-5	41	11.4	12.0	12.6
FH26-45S-0.3SHW	CL580-0211-5	45	12.6	13.2	13.8
FH26-51S-0.3SHW	CL580-0200-9	51	14.4	15.0	15.6
FH26-57S-0.3SHW	CL580-0212-8	57	16.2	16.8	17.4
FH26-71S-0.3SHW	CL580-0202-4	71	20.4	21.0	21.6

◆ Packaging Specification

● Embossed Carrier Tape Dimensions (Tape width of 24mm max.)

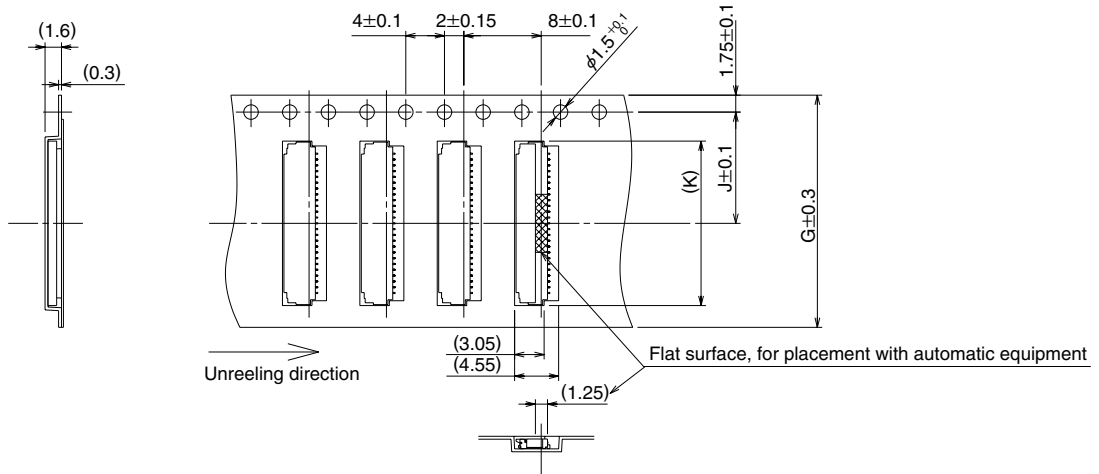

All dimensions: mm

Part Number	CL No.	Number of Contacts	G	J	K	L
FH26-13S-0.3SHW	CL580-0209-3	13	16	7.5	5.6	16.5
FH26-21S-0.3SHW	CL580-0207-8	21	16	7.5	8.0	16.5
FH26-23S-0.3SHW	CL580-0203-7	23	16	7.5	8.6	16.5
FH26-25S-0.3SHW	CL580-0208-0	25	16	7.5	9.2	16.5
FH26-27S-0.3SHW	CL580-0204-0	27	16	7.5	9.8	16.5
FH26-33S-0.3SHW	CL580-0210-2	33	24	11.5	11.6	24.5
FH26-35S-0.3SHW	CL580-0205-2	35	24	11.5	12.2	24.5
FH26-39S-0.3SHW	CL580-0201-1	39	24	11.5	13.4	24.5
FH26-41S-0.3SHW	CL580-0206-5	41	24	11.5	14.0	24.5
FH26-45S-0.3SHW	CL580-0211-5	45	24	11.5	15.2	24.5
FH26-51S-0.3SHW	CL580-0200-9	51	24	11.5	17.0	24.5

5, 000 pieces per reel.

● Embossed Carrier Tape Dimensions (Tape width of 32mm min.)

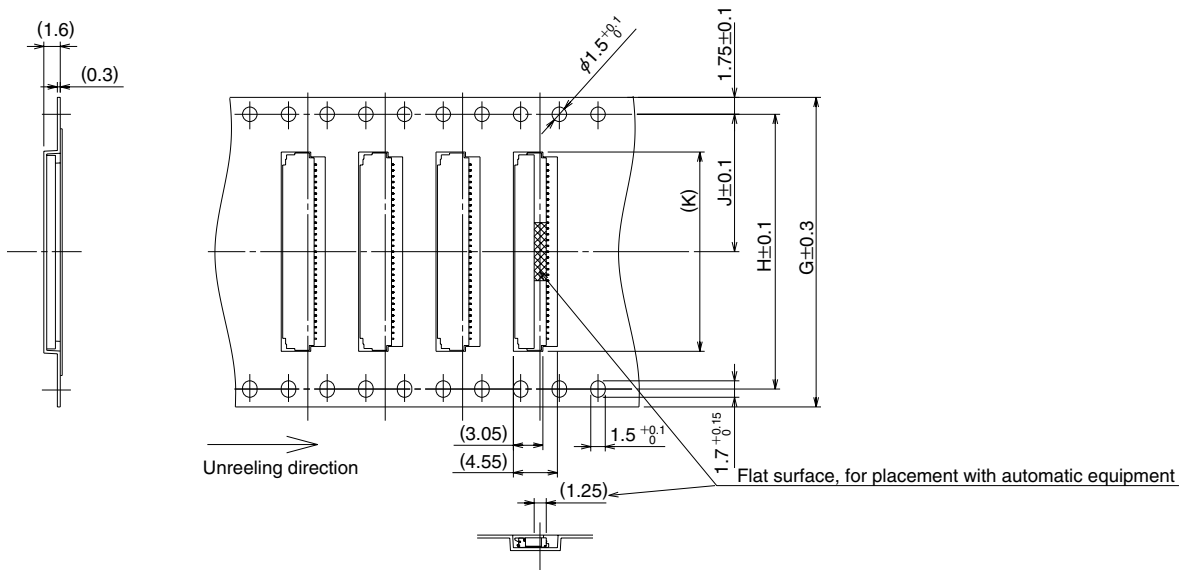

All dimensions: mm

Part Number	CL No.	Number of Contacts	G	H	J	K	L
FH26-57S-0.3SHW	CL580-0212-8	57	32	28.4	14.2	18.8	32.5
FH26-71S-0.3SHW	CL580-0202-4	71	44	40.4	20.2	23.0	44.5

●Reel Dimensions

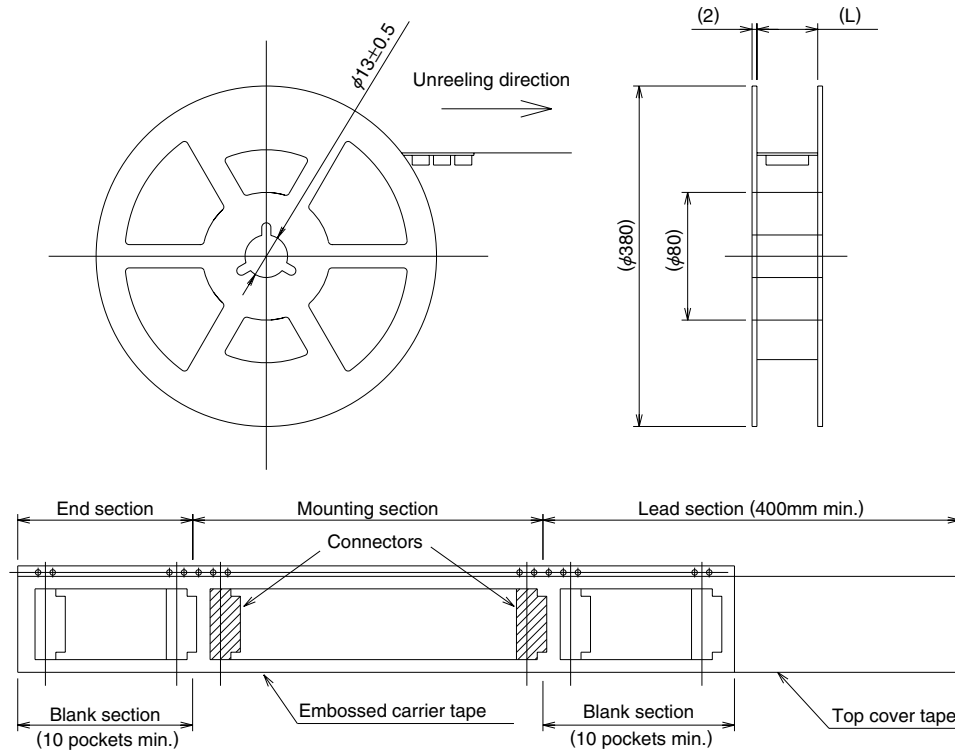

◆ Recommended Temperature Profile

● Using Typical Solder Paste

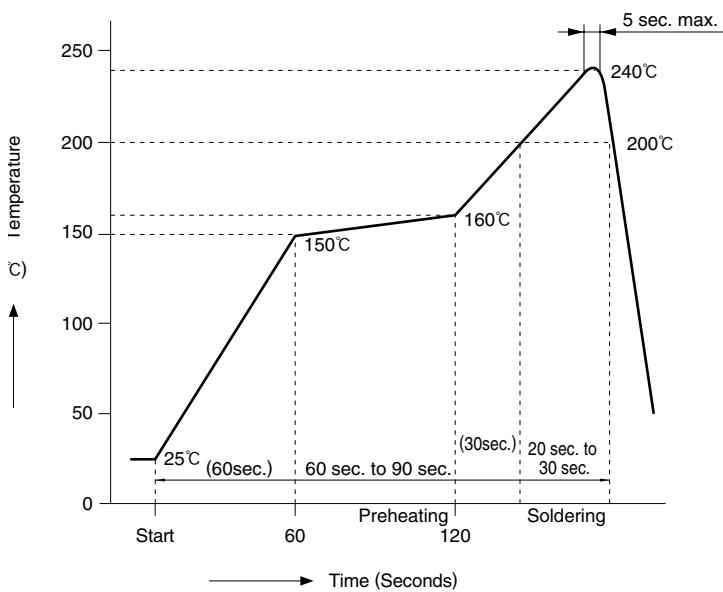

HRS test conditions

Solder method :Reflow, IR/hot air
 (Nihon Den-netsu Co., Ltd.'s
 Part Number: SENSBY NR- II)

Environment: :Room air

Solder composition: :Paste, 63%Sn/37%Pb
 (Senju Metal Industry, Co., Ltd.'s
 Part Number: OZ63-201C-50-9)

Test board :Glass epoxy 25mm×50mm×0.8mm thick

Land dimensions :0.3mm×0.65mm, 0.3mm×0.8mm

Metal mask :0.23×0.55×0.1mm thick,
 0.23×0.65×0.1mm thick

The temperature profiles are based on the above conditions. In individual applications the actual temperature may vary, depending on solder paste type, volume/thickness and board size/thickness. Consult your solder paste and equipment manufacturer for specific recommendations.

● Using Lead-free Solder Paste

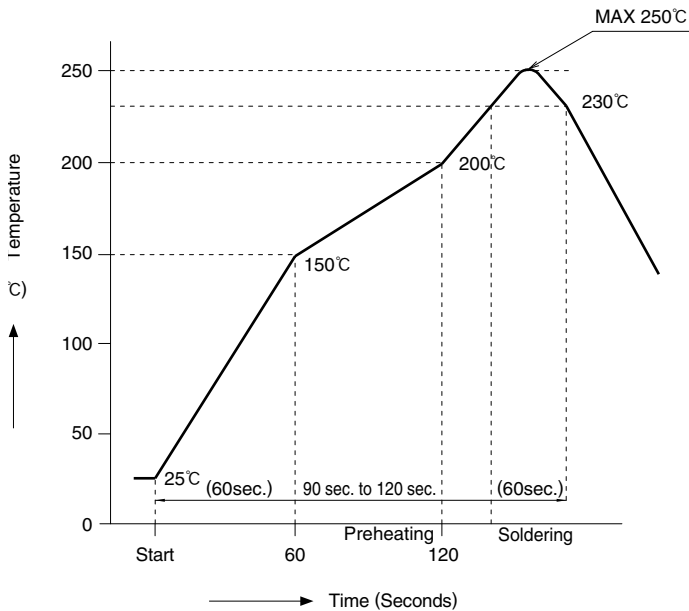

HRS test conditions

Solder method :Reflow, IR/hot air
 (Nihon Den-netsu Co., Ltd.'s
 Part Number: SENSBY NR-NR- II)

Environment :Room air

Solder composition :Paste, 96.5%Sn/3.0%Ag/0.5%Cu
 (Senju Metal Industry, Co., Ltd.'s
 Part Number: M705-221CM5-42-10.5)

Test board :Glass epoxy 25mm×50mm×0.8mm thick

Land dimensions :0.3mm×0.65mm, 0.3mm×0.8mm

Metal mask :0.23×0.55×0.1mm thick,
 0.23×0.65×0.1mm thick

The temperature profiles are based on the above conditions. In individual applications the actual temperature may vary, depending on solder paste type, volume/thickness and board size/thickness. Consult your solder paste and equipment manufacturer for specific recommendations.

◆ Recommended FPC Construction

● Contact FPC manufacturer for specific details.

1. Using Single-sided FPC

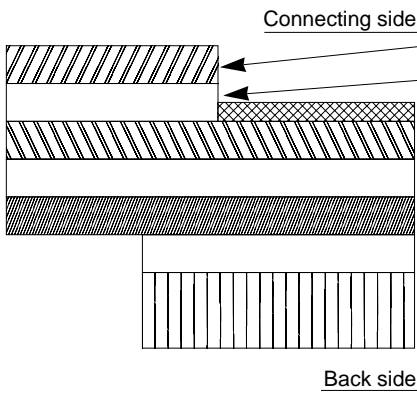

Material Name	Material	Thickness (μm)
Covering film layer.	Polyamide 1 mil thick.	25
Cover adhesive		25
Surface treatment	Tin-lead plated	5
Copper foil	Cu 1/2oz	35
Base adhesive	Thermosetting adhesive	25
Base film	Polyamide 1 mil thick	25
Reinforcement material adhesive	Thermosetting adhesive	40
Stiffener	Polyamide 3 mil thick	75
Total		205

2. Using Double-sided FPC

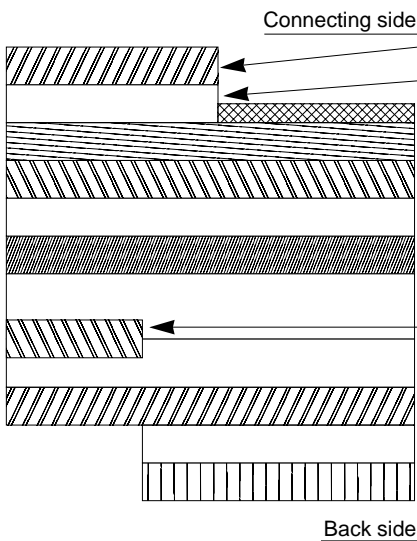

Material Name	Material	Thickness (μm)
Covering layer film	Polyamide 1 mil thick	25
Cover adhesive		25
Surface treatment	Tin-lead plated	5
Through-hole copper	Cu	15
Copper foil	Cu 1/2oz	18
Base adhesive	Thermosetting adhesive	18
Base film	Polyamide 1 mil thick	25
Base adhesive	Thermosetting adhesive	18
Copper foil	Cu 1/2oz	18
Cover adhesive	Thermosetting adhesive	25
Covering layer film	Polyamide 1 mil thick	25
Reinforcement material adhesive	Thermosetting adhesive	25
Stiffener	Polyamide 1 mil thick	25
Total		199

● To prevent release of the FPC due to its bending, use of double sided FPC with copper foil on the back side is NOT RECOMMENDED.

◆ Operation and Precautions

Operation

1.FPC insertion procedure. Connector installed on the board.

- ① Lift up the actuator. Use thumb or index finger.

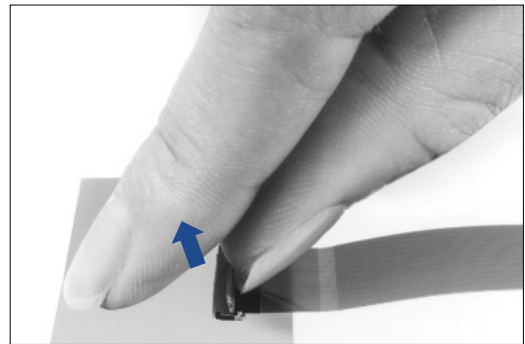

- ② Fully insert the FPC in the connector parallel to mounting surface, with the exposed conductive traces facing down.

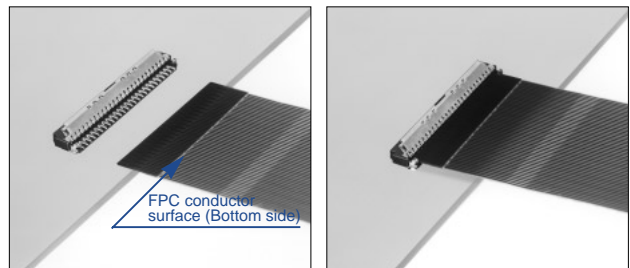

- ③ Rotate down the actuator until firmly closed. It is critical that the inserted FPC is not moved and remains fully inserted.

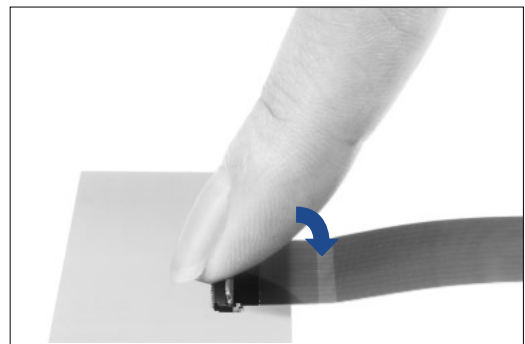

2.FPC removal

- ① Lift up the actuator. Carefully withdraw the FPC.

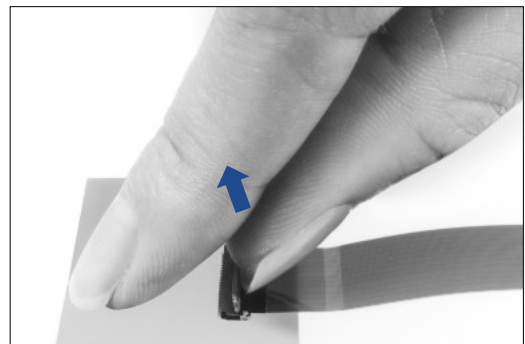

Precautions

Exercise care when handling connectors. Follow recommendations given below.

PC board flexing

◆ PC board connector mounting area

The connectors are straight within 0.1 mm max.

Make sure that the PC board connector mounting area flatness can accept the connector terminals without causing any failure of the solder joints.

◆ Handling before mounting on PCB

Insertion of the FPC or operation of the actuator prior to mounting on the PCB is NOT RECOMMENDED.

◆ PC Board handling

Exercise caution when handling boards with the connectors installed. Do not apply any forces affecting soldered joints.

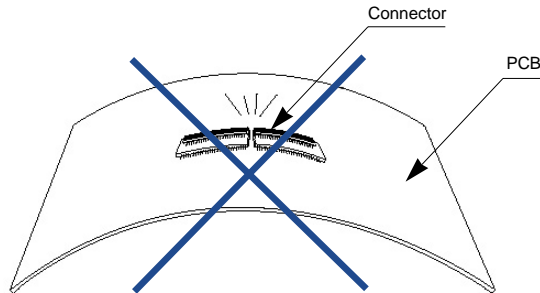

Precautions When Inserting or Coupling FPC

Pay attention to the following points when inserting FPC.

◆ Actuator operation

① Do not apply excessive force when opening the actuator prior to FPC insertion. When opening make sure that the force is applied only to the actuator itself, avoiding touching of the contacts.

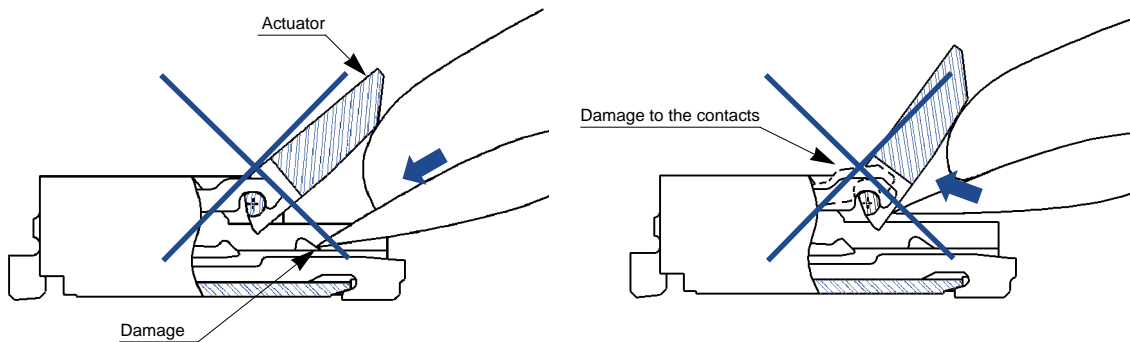

② Axis of rotation

Assure free rotation of the actuator

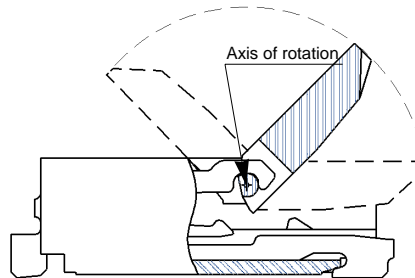

Precautions

- ③ The actuator will rotate 135 degrees maximum. Do not apply force to rotate further.

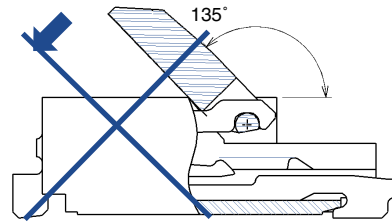

- ④ When operating the actuator, do so at the center portion.

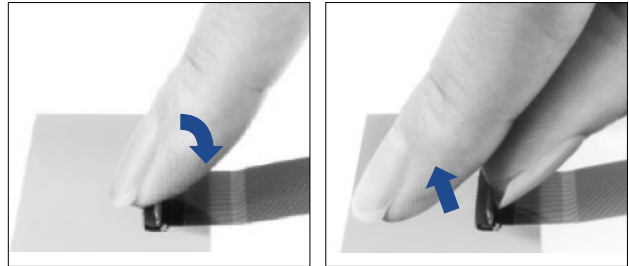

- ⑤ As illustrated, do not attempt removal or repositioning of the actuator.

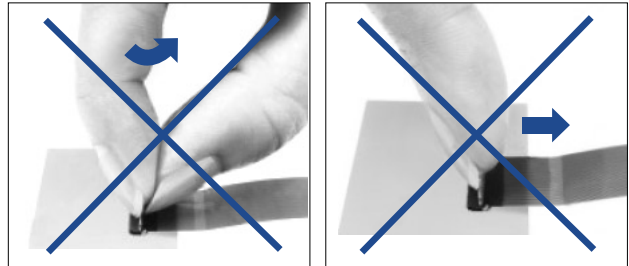

◆ FPC Insertion①

The FPC should be aligned parallel with the board surface and perpendicular with the connector (as shown), then completely inserted.

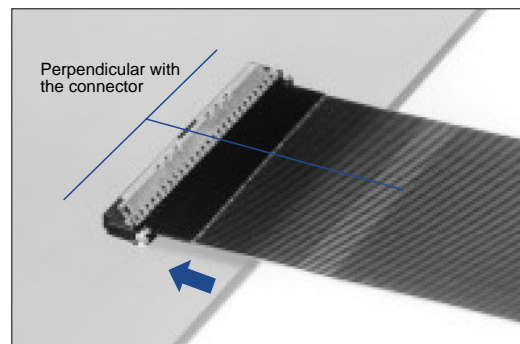
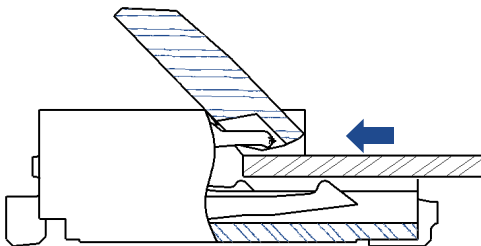

To assure correct electrical and mechanical connection do not insert FPC at angle. It must be fully inserted.

Make sure that the FPC is NOT MOVED during the closing of the actuator.

Precautions

◆ FPC Insertion②

Do not insert the FPC at any angle from above.

As illustrated, angle insertion may cause electrical discontinuity when the FPC is deflected in use.

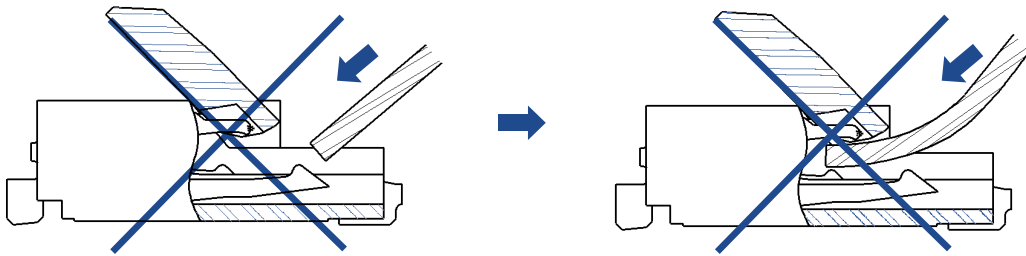

*To avert insertion of the FPC on an angle, consideration should be given to securing FPC insertion space at the time of board layout. Insertion will be difficult when the FPC is too short.

*Contact the FPC manufacturer for information about the bending specifications.

◆ Verification of the fully closed actuator.

The actuator should be fully closed (as illustrated) and the FPC held firmly in the connector.

Do not press against the actuator when is fully closed. Max force applied to the fully closed actuator should not exceed 1 N.

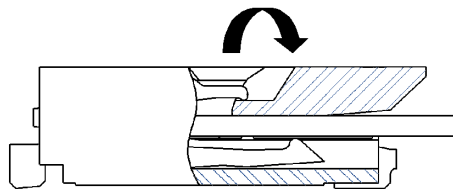

Routing the FPC (FPC fully inserted/ actuator closed)

◆ FPC Load

Do not apply force in excess of 0.05N/pin max. in the upward direction (as illustrated). Do not bend the FPC too close to the actuator.

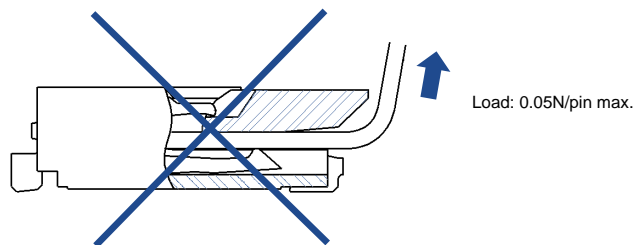

Precautions

Removing the FPC

Rotate the actuator to the open position (maximum open angle of 135°). Carefully withdraw the FPC.

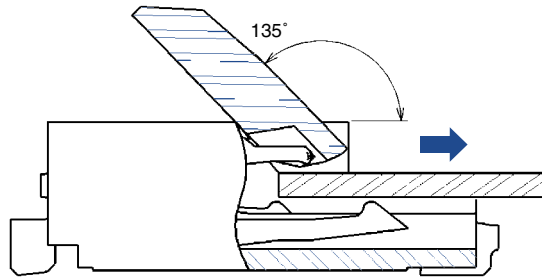
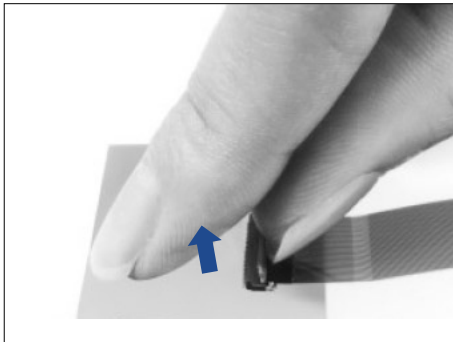

Other Precautions

◆ Hand Soldering Precautions

When hand soldering:

- ① Do not perform reflow or hand soldering with the FPC inserted in the connector.
- ② Do not apply excessive heat or touch the soldering iron anywhere other than the connector leads.
- ③ Do not use excessive amount of solder or flux compounds.

Operation of the actuator and contacts may be affected by excessive amounts of solder or flux compounds.