

SSD2215

Product Proposal

**240 RGB x 320 262K/16M Ramless a-TFT Driver
and integrated MIPI 1.01_r5 (D-PHY 0.85) system**

This document contains information on a product under definition stage. Solomon Systech reserves the right to change or discontinue this product without notice.

<http://www.solomon-systech.com>

SSD2215

Rev 0.10

P 1/37

Oct 2007

Copyright © 2007 Solomon Systech Limited



CONTENTS

1	GENERAL DESCRIPTION	5
2	FEATURES.....	5
3	ORDERING INFORMATION	6
4	BLOCK DIAGRAM	7
5	DIE PAD FLOOR PLAN	8
6	PIN DESCRIPTIONS	19
7	FUNCTIONAL BLOCK DESCRIPTIONS.....	23
7.1	SYSTEM INTERFACE.....	23
7.2	THE MIPI INTERFACE.....	23
7.3	THE MIPI BLOCK STRUCTURE.....	24
7.4	MIPI CONTROLLER	24
7.4.1	<i>D-PHY controller</i>	24
7.4.2	<i>Protocol Control Unit (PCU)</i>	24
7.4.3	<i>Packet Processing Unit (PPU)</i>	24
7.4.4	<i>Error Correction Code/ Cyclic Redundancy Check (ECC/CRC)</i>	24
7.4.5	<i>Internal Data and Command Buffer</i>	25
7.5	ANALOG TRANSCEIVER	25
7.6	GAMMA/GRAYSCALE VOLTAGE GENERATOR	26
7.7	BOOSTER AND REGULATOR CIRCUIT	26
7.8	OSCILLATION CIRCUIT (OSC)	26
7.9	DATA LATCHES	26
8	COMMAND TABLE	27
9	GAMMA ADJUSTMENT FUNCTION.....	30
9.1	STRUCTURE OF GRAYSCALE AMPLIFIER.....	31
9.2	SEPARATE RGB GAMMA ADJUSTMENT.....	33
10	APPLICATION CIRCUIT	34

TABLES

TABLE 3-1: ORDERING INFORMATION	6
TABLE 5-1: SSD2215 BUMP DIE PAD COORDINATES (BUMP CENTRE)	9
TABLE 6-1: POWER SUPPLY PINS.....	19
TABLE 6-2 - INTERFACE LOGIC PINS.....	20
TABLE 6-3: MIPI PINS.....	21
TABLE 6-4: MODE SELECTION PINS.....	21
TABLE 6-5: DRIVER OUTPUT PINS.....	21
TABLE 6-6: PHOTO SENSOR PINS	22
TABLE 8-1: COMMAND TABLE	27

Confidential

FIGURES

FIGURE 4-1 : SSD2215 BLOCK DIAGRAM.....	7
FIGURE 5-1: SSD2215 DIE PAD FLOOR PLAN.....	8
FIGURE 10-1: BOOSTER CAPACITORS	34
FIGURE 10-2: FILTERING AND CHARGE SHARING CAPACITORS	34
FIGURE 10-3 - POWER SUPPLY PINS CONNECTIONS (EXAMPLES).....	35
FIGURE 10-5 - APPLICATION DIAGRAM	36

Confidential

1 GENERAL DESCRIPTION

SSD2215 is an all in one display driver that integrated the power circuits, source driver, gate driver and high speed MIPI into a single chip. SSD2215 can drive a 262K/16M color a-TFT panel with resolution of 240 RGB sources \times 320 gates.

SSD2215 embeds a high efficient DC-DC Converter and a Voltage Regulator to generate all necessary voltage level to the a-TFT panel with minimum external components required. The SSD2215 provides a 8-color power saving mode to reduce the energy consumption in portable devices. The sources and gate scan direction can be controlled by software command.

It supports MIPI 18/24-bit/pixel interface. It contains two differential pairs for differential data transfer and differential clock. It can support 240 \times 320 \times 18/24bit \times 60Hz real time display.

2 FEATURES

- 240RGB \times 320 single chip controller driver IC for 262k/16.7M color amorphous TFT LCD with integrated MIPI interface
- Power Supply:
 - $V_{DDIO} = 1.65V \sim 3.6V$ (I/O Interface)
 - $V_{CI} = 2.50V \sim 3.60V$ (Power supply for internal analog circuit)
- Output Voltages
 - Gate Driver:
 - $V_{GH} - GND = 9V \sim 18V$
 - $V_{GL} - GND = -6V \sim -15V$
 - $V_{GH} - V_{GL} = 30V_{p-p}$ (max.)
 - Source Driver:
 - $V_0 - V_{255} = 0 \sim 5.5V$
 - Typical source Output Voltage variation : $\pm 10mV$
 - VCOM driver:
 - $V_{COMH} = 3.0V \sim 6.0V$
 - $V_{COML} = 0.0V \sim -3.0V$
 - VCOM amplitude = 6V(max)
- System Interface
 - MIPI 1.01_r5 (D-PHY 0.85)
 - Serial Peripheral Interface (SPI)
- Support low power consumption
 - Low current sleep mode
 - 8-color display mode for power saving
- Charge sharing function for switching circuits
- Internal power supply circuit
 - Voltage generator
 - DC-DC converter up to 6x/-5x
- Built-in internal oscillator
- Support Frame and Line inversion AC drive
- Support source and gate scan direction control
- TFT storage capacitance: Cs on common
- 3 Programmable gamma correction curves for Red, Green and Blue
- 4 Preset gamma correction curves
- Built-in Non Volatile Memory for VCOM calibration
- Available in COG package

3 ORDERING INFORMATION

Table 3-1: Ordering Information

Ordering Part Number	Source	Gate	Package Form	Reference	Remark
SSD2215Z	240 x 3 (720)	320	Gold Bump Die		

Confidential

4 BLOCK DIAGRAM

Figure 4-1 : SSD2215 Block Diagram

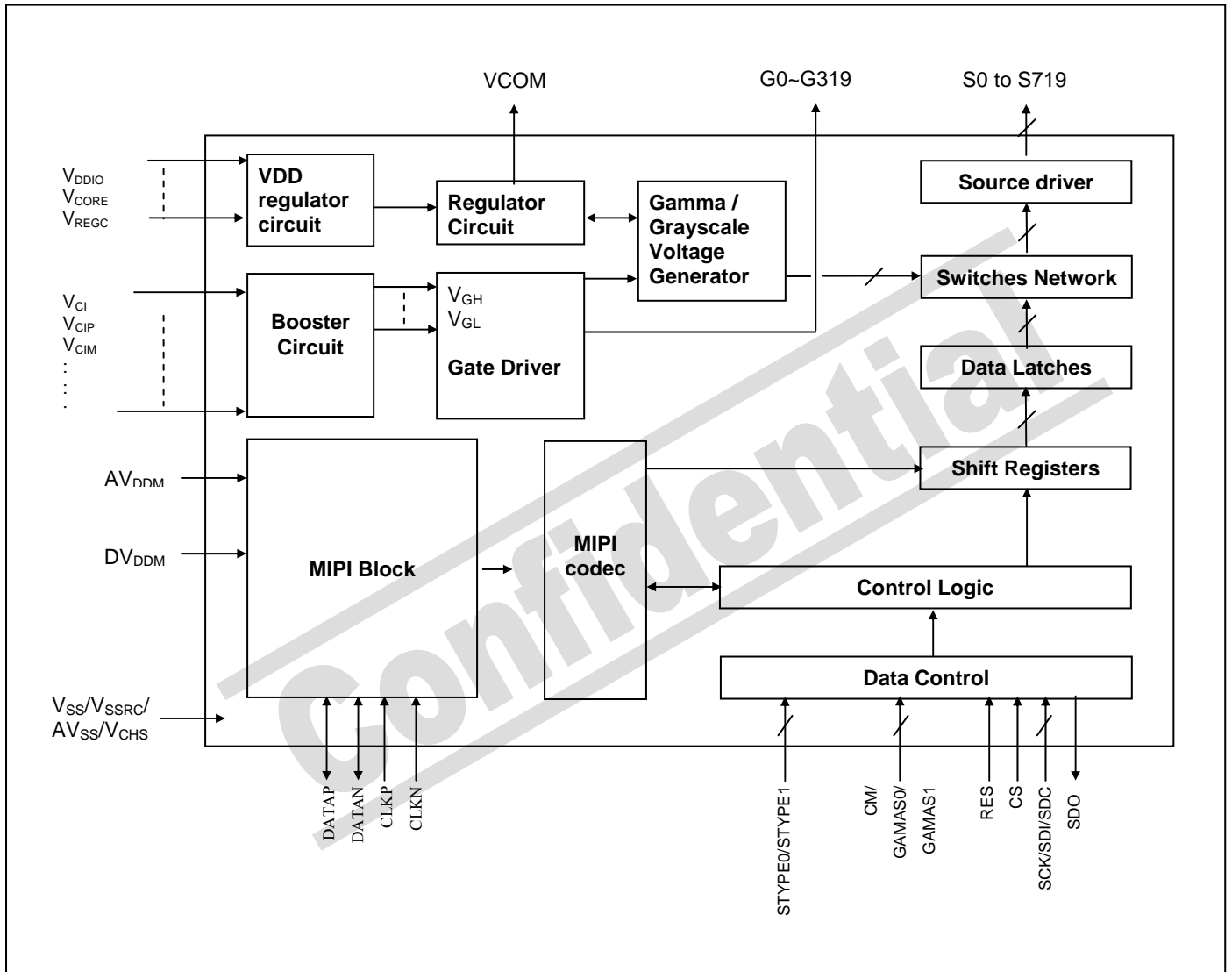

5 DIE PAD FLOOR PLAN

Figure 5-1: SSD2215 Die Pad Floor Plan

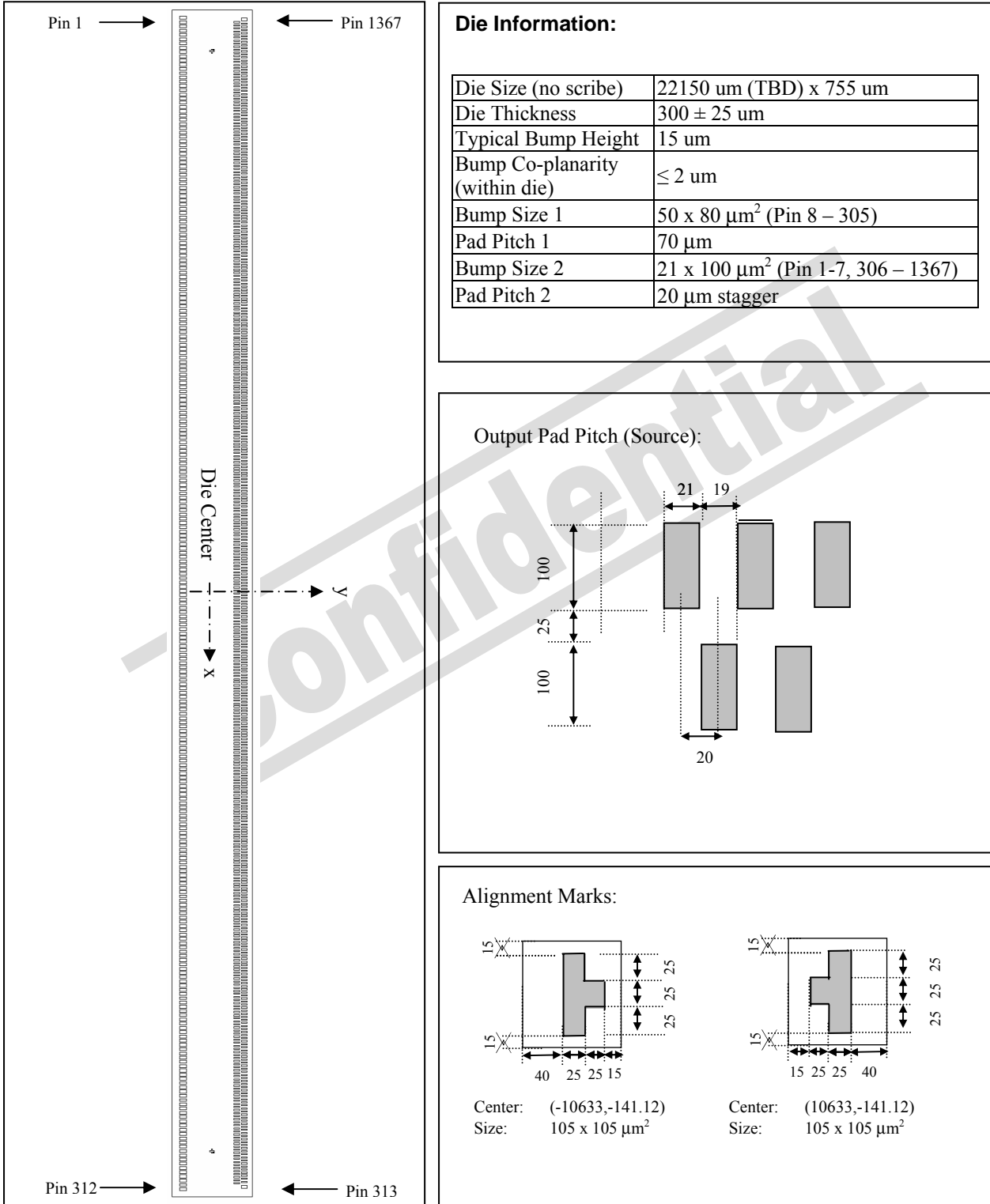

Table 5-1: SSD2215 Bump Die Pad Coordinates (Bump Centre)

Pad #	Pad Name	X-pos	Y-pos	Pad #	Pad Name	X-pos	Y-pos	Pad #	Pad Name	X-pos	Y-pos
1	DUMMY	-10675.000	-305.620	51	NC	-7175.000	-305.620	101	IOGND	-3675.000	-305.620
2	LSENFBI	-10605.000	-305.620	52	LSENFBI	-7105.000	-305.620	102	VDDIO	-3605.000	-305.620
3	LSENFBI2	-10535.000	-305.620	53	LSENFBI5	-7035.000	-305.620	103	VDDIO	-3535.000	-305.620
4	LSENFBI3	-10465.000	-305.620	54	LSENFBI6	-6965.000	-305.620	104	VDDIO	-3465.000	-305.620
5	TEST1	-10395.000	-305.620	55	VSS	-6895.000	-305.620	105	VDDIO	-3395.000	-305.620
6	TEST2	-10325.000	-305.620	56	STYPE0	-6825.000	-305.620	106	VDDIO	-3325.000	-305.620
7	TEST3	-10255.000	-305.620	57	STYPE1	-6755.000	-305.620	107	VDDIO	-3255.000	-305.620
8	TEST4	-10185.000	-305.620	58	SPID	-6685.000	-305.620	108	VDDIO	-3185.000	-305.620
9	CDUM0	-10115.000	-305.620	59	SENSW	-6615.000	-305.620	109	VCIR	-3115.000	-305.620
10	CDUM0	-10045.000	-305.620	60	TS	-6545.000	-305.620	110	VCIR	-3045.000	-305.620
11	CDUM0	-9975.000	-305.620	61	RBCLK	-6475.000	-305.620	111	VCIR	-2975.000	-305.620
12	VPP	-9905.000	-305.620	62	VSS	-6405.000	-305.620	112	VCIR	-2905.000	-305.620
13	VPP	-9835.000	-305.620	63	SDI	-6335.000	-305.620	113	VCIR	-2835.000	-305.620
14	VPP	-9765.000	-305.620	64	SCK	-6265.000	-305.620	114	VCIR	-2765.000	-305.620
15	VPP	-9695.000	-305.620	65	SDC	-6195.000	-305.620	115	VCIR	-2695.000	-305.620
16	VPP	-9625.000	-305.620	66	CS	-6125.000	-305.620	116	VCIR	-2625.000	-305.620
17	VSS	-9555.000	-305.620	67	NC	-6055.000	-305.620	117	DVDDM	-2555.000	-305.620
18	VSS	-9485.000	-305.620	68	APAD	-5985.000	-305.620	118	DVDDM	-2485.000	-305.620
19	VSS	-9415.000	-305.620	69	APAD	-5915.000	-305.620	119	DVDDM	-2415.000	-305.620
20	VDDIO	-9345.000	-305.620	70	SDO	-5845.000	-305.620	120	DVDDM	-2345.000	-305.620
21	VDDIO	-9275.000	-305.620	71	TEST5	-5775.000	-305.620	121	DVDDM	-2275.000	-305.620
22	VSS	-9205.000	-305.620	72	TEST6	-5705.000	-305.620	122	AVDDM	-2205.000	-305.620
23	VSS	-9135.000	-305.620	73	TEST7	-5635.000	-305.620	123	AVDDM	-2135.000	-305.620
24	CLKN	-9065.000	-305.620	74	TEST8	-5565.000	-305.620	124	AVDDM	-2065.000	-305.620
25	CLKN	-8995.000	-305.620	75	TEST9	-5495.000	-305.620	125	AVDDM	-1995.000	-305.620
26	CLKN	-8925.000	-305.620	76	TEST10	-5425.000	-305.620	126	VREGCM	-1925.000	-305.620
27	CLKN	-8855.000	-305.620	77	TEST11	-5355.000	-305.620	127	VREGCM	-1855.000	-305.620
28	CLKP	-8785.000	-305.620	78	TEST12	-5285.000	-305.620	128	VREGCM	-1785.000	-305.620
29	CLKP	-8715.000	-305.620	79	TEST13	-5215.000	-305.620	129	VREGCM	-1715.000	-305.620
30	CLKP	-8645.000	-305.620	80	TEST14	-5145.000	-305.620	130	NC	-1645.000	-305.620
31	CLKP	-8575.000	-305.620	81	TEST15	-5075.000	-305.620	131	NC	-1575.000	-305.620
32	VSS	-8505.000	-305.620	82	TEST16	-5005.000	-305.620	132	NC	-1505.000	-305.620
33	VSS	-8435.000	-305.620	83	TEST17	-4935.000	-305.620	133	NC	-1435.000	-305.620
34	VSS	-8365.000	-305.620	84	TEST18	-4865.000	-305.620	134	TEST A	-1365.000	-305.620
35	VSS	-8295.000	-305.620	85	TEST19	-4795.000	-305.620	135	TEST B	-1295.000	-305.620
36	DATAN	-8225.000	-305.620	86	TEST20	-4725.000	-305.620	136	NC	-1225.000	-305.620
37	DATAN	-8155.000	-305.620	87	TEST21	-4655.000	-305.620	137	TEST C	-1155.000	-305.620
38	DATAN	-8085.000	-305.620	88	TEST22	-4585.000	-305.620	138	VCHS	-1085.000	-305.620
39	DATAN	-8015.000	-305.620	89	TEST23	-4515.000	-305.620	139	VCHS	-1015.000	-305.620
40	DATAP	-7945.000	-305.620	90	TEST24	-4445.000	-305.620	140	VCHS	-945.000	-305.620
41	DATAP	-7875.000	-305.620	91	TEST25	-4375.000	-305.620	141	VCHS	-875.000	-305.620
42	DATAP	-7805.000	-305.620	92	TEST26	-4305.000	-305.620	142	VCHS	-805.000	-305.620
43	DATAP	-7735.000	-305.620	93	TEST27	-4235.000	-305.620	143	VCHS	-735.000	-305.620
44	VSS	-7665.000	-305.620	94	TEST28	-4165.000	-305.620	144	VCHS	-665.000	-305.620
45	VSS	-7595.000	-305.620	95	IOGND	-4095.000	-305.620	145	VCHS	-595.000	-305.620
46	RES	-7525.000	-305.620	96	IOGND	-4025.000	-305.620	146	VCHS	-525.000	-305.620
47	CM	-7455.000	-305.620	97	IOGND	-3955.000	-305.620	147	VCHS	-455.000	-305.620
48	GAMAS1	-7385.000	-305.620	98	IOGND	-3885.000	-305.620	148	VCHS	-385.000	-305.620
49	GAMAS0	-7315.000	-305.620	99	IOGND	-3815.000	-305.620	149	HC	-315.000	-305.620
50	NC	-7245.000	-305.620	100	IOGND	-3745.000	-305.620	150	HC	-245.000	-305.620

Pad #	Pad Name	X-pos	Y-pos	Pad #	Pad Name	X-pos	Y-pos	Pad #	Pad Name	X-pos	Y-pos
151	AVSS	-175.000	-305.620	201	VCIM	3325.000	-305.620	251	NC	6825.000	-305.620
152	AVSS	-105.000	-305.620	202	VCIM	3395.000	-305.620	252	VGL	6895.000	-305.620
153	AVSS	-35.000	-305.620	203	VCIM	3465.000	-305.620	253	VGL	6965.000	-305.620
154	AVSS	35.000	-305.620	204	VCIX2G	3535.000	-305.620	254	VGL	7035.000	-305.620
155	VSS	105.000	-305.620	205	VCIX2G	3605.000	-305.620	255	VGL	7105.000	-305.620
156	VSS	175.000	-305.620	206	VCIX2G	3675.000	-305.620	256	VGL	7175.000	-305.620
157	VSS	245.000	-305.620	207	VCIX2	3745.000	-305.620	257	VGL	7245.000	-305.620
158	VSS	315.000	-305.620	208	VCIX2	3815.000	-305.620	258	VGL	7315.000	-305.620
159	VSS	385.000	-305.620	209	VCIX2	3885.000	-305.620	259	VGL	7385.000	-305.620
160	VSS	455.000	-305.620	210	VCIX2	3955.000	-305.620	260	VGL	7455.000	-305.620
161	VSS	525.000	-305.620	211	VCIX2	4025.000	-305.620	261	VGL	7525.000	-305.620
162	VSS	595.000	-305.620	212	VCIX2	4095.000	-305.620	262	VGL	7595.000	-305.620
163	VSS	665.000	-305.620	213	VCIX2	4165.000	-305.620	263	VGL	7665.000	-305.620
164	VSS	735.000	-305.620	214	VCORE	4235.000	-305.620	264	NC	7735.000	-305.620
165	NC	805.000	-305.620	215	VCORE	4305.000	-305.620	265	NC	7805.000	-305.620
166	NC	875.000	-305.620	216	VCORE	4375.000	-305.620	266	NC	7875.000	-305.620
167	NC	945.000	-305.620	217	VREGC	4445.000	-305.620	267	VGH	7945.000	-305.620
168	EXVR	1015.000	-305.620	218	VREGC	4515.000	-305.620	268	VGH	8015.000	-305.620
169	NC	1085.000	-305.620	219	VREGC	4585.000	-305.620	269	VGH	8085.000	-305.620
170	NC	1155.000	-305.620	220	VREGC	4655.000	-305.620	270	VGH	8155.000	-305.620
171	NC	1225.000	-305.620	221	VREGC	4725.000	-305.620	271	VGH	8225.000	-305.620
172	NC	1295.000	-305.620	222	VCIP	4795.000	-305.620	272	VGH	8295.000	-305.620
173	NC	1365.000	-305.620	223	VCI	4865.000	-305.620	273	NC	8365.000	-305.620
174	NC	1435.000	-305.620	224	VCI	4935.000	-305.620	274	C3N	8435.000	-305.620
175	VCOM	1505.000	-305.620	225	VCI	5005.000	-305.620	275	C3N	8505.000	-305.620
176	VCOM	1575.000	-305.620	226	VCI	5075.000	-305.620	276	C3N	8575.000	-305.620
177	VCOM	1645.000	-305.620	227	VCI	5145.000	-305.620	277	NC	8645.000	-305.620
178	VCOM	1715.000	-305.620	228	VCI	5215.000	-305.620	278	C3P	8715.000	-305.620
179	VCOM	1785.000	-305.620	229	VCI	5285.000	-305.620	279	C3P	8785.000	-305.620
180	VCOM	1855.000	-305.620	230	VCI	5355.000	-305.620	280	C3P	8855.000	-305.620
181	VCOMH	1925.000	-305.620	231	CYN	5425.000	-305.620	281	NC	8925.000	-305.620
182	VCOMH	1995.000	-305.620	232	CYN	5495.000	-305.620	282	C1N	8995.000	-305.620
183	VCOMH	2065.000	-305.620	233	CYN	5565.000	-305.620	283	C1N	9065.000	-305.620
184	VCOMH	2135.000	-305.620	234	CYN	5635.000	-305.620	284	C1N	9135.000	-305.620
185	VCOMH	2205.000	-305.620	235	CYN	5705.000	-305.620	285	C1P	9205.000	-305.620
186	VCOMH	2275.000	-305.620	236	CYP	5775.000	-305.620	286	C1P	9275.000	-305.620
187	VCOML	2345.000	-305.620	237	CYP	5845.000	-305.620	287	C1P	9345.000	-305.620
188	VCOML	2415.000	-305.620	238	CYP	5915.000	-305.620	288	C2N	9415.000	-305.620
189	VCOML	2485.000	-305.620	239	CYP	5985.000	-305.620	289	C2N	9485.000	-305.620
190	VCOML	2555.000	-305.620	240	CYP	6055.000	-305.620	290	C2N	9555.000	-305.620
191	VCOML	2625.000	-305.620	241	CXN	6125.000	-305.620	291	C2P	9625.000	-305.620
192	VCOML	2695.000	-305.620	242	CXN	6195.000	-305.620	292	C2P	9695.000	-305.620
193	NC	2765.000	-305.620	243	CXN	6265.000	-305.620	293	C2P	9765.000	-305.620
194	NC	2835.000	-305.620	244	CXN	6335.000	-305.620	294	CSVCMN	9835.000	-305.620
195	VLCD255	2905.000	-305.620	245	CXN	6405.000	-305.620	295	CSVCMN	9905.000	-305.620
196	NC	2975.000	-305.620	246	CXP	6475.000	-305.620	296	CSVCMN	9975.000	-305.620
197	NC	3045.000	-305.620	247	CXP	6545.000	-305.620	297	CSVCMP	10045.000	-305.620
198	NC	3115.000	-305.620	248	CXP	6615.000	-305.620	298	CSVCMP	10115.000	-305.620
199	VCOMR	3185.000	-305.620	249	CXP	6685.000	-305.620	299	CSVCMP	10185.000	-305.620
200	LSENV	3255.000	-305.620	250	CXP	6755.000	-305.620	300	NC	10255.000	-305.620

Pad #	Pad Name	X-pos	Y-pos	Pad #	Pad Name	X-pos	Y-pos	Pad #	Pad Name	X-pos	Y-pos
301	NC	10325.000	-305.620	351	G73	9850.000	168.380	401	G173	8850.000	168.380
302	NC	10395.000	-305.620	352	G75	9830.000	293.380	402	G175	8830.000	293.380
303	LSENF7	10465.000	-305.620	353	G77	9810.000	168.380	403	G177	8810.000	168.380
304	LSENF8	10535.000	-305.620	354	G79	9790.000	293.380	404	G179	8790.000	293.380
305	LSENF9	10605.000	-305.620	355	G81	9770.000	168.380	405	G181	8770.000	168.380
306	DUMMY	10675.000	-305.620	356	G83	9750.000	293.380	406	G183	8750.000	293.380
307	DUMMY	10750.000	168.380	357	G85	9730.000	168.380	407	G185	8730.000	168.380
308	DUMMY	10710.000	293.380	358	G87	9710.000	293.380	408	G187	8710.000	293.380
309	DUMMY	10690.000	168.380	359	G89	9690.000	168.380	409	G189	8690.000	168.380
310	DUMMY	10670.000	293.380	360	G91	9670.000	293.380	410	G191	8670.000	293.380
311	LSENI1	10650.000	168.380	361	G93	9650.000	168.380	411	G193	8650.000	168.380
312	LSENI2	10630.000	293.380	362	G95	9630.000	293.380	412	G195	8630.000	293.380
313	LSENI3	10610.000	168.380	363	G97	9610.000	168.380	413	G197	8610.000	168.380
314	MFF-G	10590.000	293.380	364	G99	9590.000	293.380	414	G199	8590.000	293.380
315	G1	10570.000	168.380	365	G101	9570.000	168.380	415	G201	8570.000	168.380
316	G3	10550.000	293.380	366	G103	9550.000	293.380	416	G203	8550.000	293.380
317	G5	10530.000	168.380	367	G105	9530.000	168.380	417	G205	8530.000	168.380
318	G7	10510.000	293.380	368	G107	9510.000	293.380	418	G207	8510.000	293.380
319	G9	10490.000	168.380	369	G109	9490.000	168.380	419	G209	8490.000	168.380
320	G11	10470.000	293.380	370	G111	9470.000	293.380	420	G211	8470.000	293.380
321	G13	10450.000	168.380	371	G113	9450.000	168.380	421	G213	8450.000	168.380
322	G15	10430.000	293.380	372	G115	9430.000	293.380	422	G215	8430.000	293.380
323	G17	10410.000	168.380	373	G117	9410.000	168.380	423	G217	8410.000	168.380
324	G19	10390.000	293.380	374	G119	9390.000	293.380	424	G219	8390.000	293.380
325	G21	10370.000	168.380	375	G121	9370.000	168.380	425	G221	8370.000	168.380
326	G23	10350.000	293.380	376	G123	9350.000	293.380	426	G223	8350.000	293.380
327	G25	10330.000	168.380	377	G125	9330.000	168.380	427	G225	8330.000	168.380
328	G27	10310.000	293.380	378	G127	9310.000	293.380	428	G227	8310.000	293.380
329	G29	10290.000	168.380	379	G129	9290.000	168.380	429	G229	8290.000	168.380
330	G31	10270.000	293.380	380	G131	9270.000	293.380	430	G231	8270.000	293.380
331	G33	10250.000	168.380	381	G133	9250.000	168.380	431	G233	8250.000	168.380
332	G35	10230.000	293.380	382	G135	9230.000	293.380	432	G235	8230.000	293.380
333	G37	10210.000	168.380	383	G137	9210.000	168.380	433	G237	8210.000	168.380
334	G39	10190.000	293.380	384	G139	9190.000	293.380	434	G239	8190.000	293.380
335	G41	10170.000	168.380	385	G141	9170.000	168.380	435	G241	8170.000	168.380
336	G43	10150.000	293.380	386	G143	9150.000	293.380	436	G243	8150.000	293.380
337	G45	10130.000	168.380	387	G145	9130.000	168.380	437	G245	8130.000	168.380
338	G47	10110.000	293.380	388	G147	9110.000	293.380	438	G247	8110.000	293.380
339	G49	10090.000	168.380	389	G149	9090.000	168.380	439	G249	8090.000	168.380
340	G51	10070.000	293.380	390	G151	9070.000	293.380	440	G251	8070.000	293.380
341	G53	10050.000	168.380	391	G153	9050.000	168.380	441	G253	8050.000	168.380
342	G55	10030.000	293.380	392	G155	9030.000	293.380	442	G255	8030.000	293.380
343	G57	10010.000	168.380	393	G157	9010.000	168.380	443	G257	8010.000	168.380
344	G59	9990.000	293.380	394	G159	8990.000	293.380	444	G259	7990.000	293.380
345	G61	9970.000	168.380	395	G161	8970.000	168.380	445	G261	7970.000	168.380
346	G63	9950.000	293.380	396	G163	8950.000	293.380	446	G263	7950.000	293.380
347	G65	9930.000	168.380	397	G165	8930.000	168.380	447	G265	7930.000	168.380
348	G67	9910.000	293.380	398	G167	8910.000	293.380	448	G267	7910.000	293.380
349	G69	9890.000	168.380	399	G169	8890.000	168.380	449	G269	7890.000	168.380
350	G71	9870.000	293.380	400	G171	8870.000	293.380	450	G271	7870.000	293.380

Pad #	Pad Name	X-pos	Y-pos	Pad #	Pad Name	X-pos	Y-pos	Pad #	Pad Name	X-pos	Y-pos
451	G273	7850.000	168.380	501	S701	6750.000	168.380	551	S651	5750.000	168.380
452	G275	7830.000	293.380	502	S700	6730.000	293.380	552	S650	5730.000	293.380
453	G277	7810.000	168.380	503	S699	6710.000	168.380	553	S649	5710.000	168.380
454	G279	7790.000	293.380	504	S698	6690.000	293.380	554	S648	5690.000	293.380
455	G281	7770.000	168.380	505	S697	6670.000	168.380	555	S647	5670.000	168.380
456	G283	7750.000	293.380	506	S696	6650.000	293.380	556	S646	5650.000	293.380
457	G285	7730.000	168.380	507	S695	6630.000	168.380	557	S645	5630.000	168.380
458	G287	7710.000	293.380	508	S694	6610.000	293.380	558	S644	5610.000	293.380
459	G289	7690.000	168.380	509	S693	6590.000	168.380	559	S643	5590.000	168.380
460	G291	7670.000	293.380	510	S692	6570.000	293.380	560	S642	5570.000	293.380
461	G293	7650.000	168.380	511	S691	6550.000	168.380	561	S641	5550.000	168.380
462	G295	7630.000	293.380	512	S690	6530.000	293.380	562	S640	5530.000	293.380
463	G297	7610.000	168.380	513	S689	6510.000	168.380	563	S639	5510.000	168.380
464	G299	7590.000	293.380	514	S688	6490.000	293.380	564	S638	5490.000	293.380
465	G301	7570.000	168.380	515	S687	6470.000	168.380	565	S637	5470.000	168.380
466	G303	7550.000	293.380	516	S686	6450.000	293.380	566	S636	5450.000	293.380
467	G305	7530.000	168.380	517	S685	6430.000	168.380	567	S635	5430.000	168.380
468	G307	7510.000	293.380	518	S684	6410.000	293.380	568	S634	5410.000	293.380
469	G309	7490.000	168.380	519	S683	6390.000	168.380	569	S633	5390.000	168.380
470	G311	7470.000	293.380	520	S682	6370.000	293.380	570	S632	5370.000	293.380
471	G313	7450.000	168.380	521	S681	6350.000	168.380	571	S631	5350.000	168.380
472	G315	7430.000	293.380	522	S680	6330.000	293.380	572	S630	5330.000	293.380
473	G317	7410.000	168.380	523	S679	6310.000	168.380	573	S629	5310.000	168.380
474	G319	7390.000	293.380	524	S678	6290.000	293.380	574	S628	5290.000	293.380
475	MFF-G	7370.000	168.380	525	S677	6270.000	168.380	575	S627	5270.000	168.380
476	LSENOUT1	7350.000	293.380	526	S676	6250.000	293.380	576	S626	5250.000	293.380
477	LSENOUT2	7330.000	168.380	527	S675	6230.000	168.380	577	S625	5230.000	168.380
478	LSENOUT3	7310.000	293.380	528	S674	6210.000	293.380	578	S624	5210.000	293.380
479	LSENIN4	7290.000	168.380	529	S673	6190.000	168.380	579	S623	5190.000	168.380
480	LSENIN5	7270.000	293.380	530	S672	6170.000	293.380	580	S622	5170.000	293.380
481	LSENIN6	7250.000	168.380	531	S671	6150.000	168.380	581	S621	5150.000	168.380
482	DUMMY	7130.000	293.380	532	S670	6130.000	293.380	582	S620	5130.000	293.380
483	S719	7110.000	168.380	533	S669	6110.000	168.380	583	S619	5110.000	168.380
484	S718	7090.000	293.380	534	S668	6090.000	293.380	584	S618	5090.000	293.380
485	S717	7070.000	168.380	535	S667	6070.000	168.380	585	S617	5070.000	168.380
486	S716	7050.000	293.380	536	S666	6050.000	293.380	586	S616	5050.000	293.380
487	S715	7030.000	168.380	537	S665	6030.000	168.380	587	S615	5030.000	168.380
488	S714	7010.000	293.380	538	S664	6010.000	293.380	588	S614	5010.000	293.380
489	S713	6990.000	168.380	539	S663	5990.000	168.380	589	S613	4990.000	168.380
490	S712	6970.000	293.380	540	S662	5970.000	293.380	590	S612	4970.000	293.380
491	S711	6950.000	168.380	541	S661	5950.000	168.380	591	S611	4950.000	168.380
492	S710	6930.000	293.380	542	S660	5930.000	293.380	592	S610	4930.000	293.380
493	S709	6910.000	168.380	543	S659	5910.000	168.380	593	S609	4910.000	168.380
494	S708	6890.000	293.380	544	S658	5890.000	293.380	594	S608	4890.000	293.380
495	S707	6870.000	168.380	545	S657	5870.000	168.380	595	S607	4870.000	168.380
496	S706	6850.000	293.380	546	S656	5850.000	293.380	596	S606	4850.000	293.380
497	S705	6830.000	168.380	547	S655	5830.000	168.380	597	S605	4830.000	168.380
498	S704	6810.000	293.380	548	S654	5810.000	293.380	598	S604	4810.000	293.380
499	S703	6790.000	168.380	549	S653	5790.000	168.380	599	S603	4790.000	168.380
500	S702	6770.000	293.380	550	S652	5770.000	293.380	600	S602	4770.000	293.380

Pad #	Pad Name	X-pos	Y-pos	Pad #	Pad Name	X-pos	Y-pos	Pad #	Pad Name	X-pos	Y-pos
601	S601	4750.000	168.380	651	S551	3750.000	168.380	701	S501	2750.000	168.380
602	S600	4730.000	293.380	652	S550	3730.000	293.380	702	S500	2730.000	293.380
603	S599	4710.000	168.380	653	S549	3710.000	168.380	703	S499	2710.000	168.380
604	S598	4690.000	293.380	654	S548	3690.000	293.380	704	S498	2690.000	293.380
605	S597	4670.000	168.380	655	S547	3670.000	168.380	705	S497	2670.000	168.380
606	S596	4650.000	293.380	656	S546	3650.000	293.380	706	S496	2650.000	293.380
607	S595	4630.000	168.380	657	S545	3630.000	168.380	707	S495	2630.000	168.380
608	S594	4610.000	293.380	658	S544	3610.000	293.380	708	S494	2610.000	293.380
609	S593	4590.000	168.380	659	S543	3590.000	168.380	709	S493	2590.000	168.380
610	S592	4570.000	293.380	660	S542	3570.000	293.380	710	S492	2570.000	293.380
611	S591	4550.000	168.380	661	S541	3550.000	168.380	711	S491	2550.000	168.380
612	S590	4530.000	293.380	662	S540	3530.000	293.380	712	S490	2530.000	293.380
613	S589	4510.000	168.380	663	S539	3510.000	168.380	713	S489	2510.000	168.380
614	S588	4490.000	293.380	664	S538	3490.000	293.380	714	S488	2490.000	293.380
615	S587	4470.000	168.380	665	S537	3470.000	168.380	715	S487	2470.000	168.380
616	S586	4450.000	293.380	666	S536	3450.000	293.380	716	S486	2450.000	293.380
617	S585	4430.000	168.380	667	S535	3430.000	168.380	717	S485	2430.000	168.380
618	S584	4410.000	293.380	668	S534	3410.000	293.380	718	S484	2410.000	293.380
619	S583	4390.000	168.380	669	S533	3390.000	168.380	719	S483	2390.000	168.380
620	S582	4370.000	293.380	670	S532	3370.000	293.380	720	S482	2370.000	293.380
621	S581	4350.000	168.380	671	S531	3350.000	168.380	721	S481	2350.000	168.380
622	S580	4330.000	293.380	672	S530	3330.000	293.380	722	S480	2330.000	293.380
623	S579	4310.000	168.380	673	S529	3310.000	168.380	723	S479	2310.000	168.380
624	S578	4290.000	293.380	674	S528	3290.000	293.380	724	S478	2290.000	293.380
625	S577	4270.000	168.380	675	S527	3270.000	168.380	725	S477	2270.000	168.380
626	S576	4250.000	293.380	676	S526	3250.000	293.380	726	S476	2250.000	293.380
627	S575	4230.000	168.380	677	S525	3230.000	168.380	727	S475	2230.000	168.380
628	S574	4210.000	293.380	678	S524	3210.000	293.380	728	S474	2210.000	293.380
629	S573	4190.000	168.380	679	S523	3190.000	168.380	729	S473	2190.000	168.380
630	S572	4170.000	293.380	680	S522	3170.000	293.380	730	S472	2170.000	293.380
631	S571	4150.000	168.380	681	S521	3150.000	168.380	731	S471	2150.000	168.380
632	S570	4130.000	293.380	682	S520	3130.000	293.380	732	S470	2130.000	293.380
633	S569	4110.000	168.380	683	S519	3110.000	168.380	733	S469	2110.000	168.380
634	S568	4090.000	293.380	684	S518	3090.000	293.380	734	S468	2090.000	293.380
635	S567	4070.000	168.380	685	S517	3070.000	168.380	735	S467	2070.000	168.380
636	S566	4050.000	293.380	686	S516	3050.000	293.380	736	S466	2050.000	293.380
637	S565	4030.000	168.380	687	S515	3030.000	168.380	737	S465	2030.000	168.380
638	S564	4010.000	293.380	688	S514	3010.000	293.380	738	S464	2010.000	293.380
639	S563	3990.000	168.380	689	S513	2990.000	168.380	739	S463	1990.000	168.380
640	S562	3970.000	293.380	690	S512	2970.000	293.380	740	S462	1970.000	293.380
641	S561	3950.000	168.380	691	S511	2950.000	168.380	741	S461	1950.000	168.380
642	S560	3930.000	293.380	692	S510	2930.000	293.380	742	S460	1930.000	293.380
643	S559	3910.000	168.380	693	S509	2910.000	168.380	743	S459	1910.000	168.380
644	S558	3890.000	293.380	694	S508	2890.000	293.380	744	S458	1890.000	293.380
645	S557	3870.000	168.380	695	S507	2870.000	168.380	745	S457	1870.000	168.380
646	S556	3850.000	293.380	696	S506	2850.000	293.380	746	S456	1850.000	293.380
647	S555	3830.000	168.380	697	S505	2830.000	168.380	747	S455	1830.000	168.380
648	S554	3810.000	293.380	698	S504	2810.000	293.380	748	S454	1810.000	293.380
649	S553	3790.000	168.380	699	S503	2790.000	168.380	749	S453	1790.000	168.380
650	S552	3770.000	293.380	700	S502	2770.000	293.380	750	S452	1770.000	293.380

Pad #	Pad Name	X-pos	Y-pos	Pad #	Pad Name	X-pos	Y-pos	Pad #	Pad Name	X-pos	Y-pos
751	S451	1750.000	168.380	801	S401	750.000	168.380	851	S351	-250.000	168.380
752	S450	1730.000	293.380	802	S400	730.000	293.380	852	S350	-270.000	293.380
753	S449	1710.000	168.380	803	S399	710.000	168.380	853	S349	-290.000	168.380
754	S448	1690.000	293.380	804	S398	690.000	293.380	854	S348	-310.000	293.380
755	S447	1670.000	168.380	805	S397	670.000	168.380	855	S347	-330.000	168.380
756	S446	1650.000	293.380	806	S396	650.000	293.380	856	S346	-350.000	293.380
757	S445	1630.000	168.380	807	S395	630.000	168.380	857	S345	-370.000	168.380
758	S444	1610.000	293.380	808	S394	610.000	293.380	858	S344	-390.000	293.380
759	S443	1590.000	168.380	809	S393	590.000	168.380	859	S343	-410.000	168.380
760	S442	1570.000	293.380	810	S392	570.000	293.380	860	S342	-430.000	293.380
761	S441	1550.000	168.380	811	S391	550.000	168.380	861	S341	-450.000	168.380
762	S440	1530.000	293.380	812	S390	530.000	293.380	862	S340	-470.000	293.380
763	S439	1510.000	168.380	813	S389	510.000	168.380	863	S339	-490.000	168.380
764	S438	1490.000	293.380	814	S388	490.000	293.380	864	S338	-510.000	293.380
765	S437	1470.000	168.380	815	S387	470.000	168.380	865	S337	-530.000	168.380
766	S436	1450.000	293.380	816	S386	450.000	293.380	866	S336	-550.000	293.380
767	S435	1430.000	168.380	817	S385	430.000	168.380	867	S335	-570.000	168.380
768	S434	1410.000	293.380	818	S384	410.000	293.380	868	S334	-590.000	293.380
769	S433	1390.000	168.380	819	S383	390.000	168.380	869	S333	-610.000	168.380
770	S432	1370.000	293.380	820	S382	370.000	293.380	870	S332	-630.000	293.380
771	S431	1350.000	168.380	821	S381	350.000	168.380	871	S331	-650.000	168.380
772	S430	1330.000	293.380	822	S380	330.000	293.380	872	S330	-670.000	293.380
773	S429	1310.000	168.380	823	S379	310.000	168.380	873	S329	-690.000	168.380
774	S428	1290.000	293.380	824	S378	290.000	293.380	874	S328	-710.000	293.380
775	S427	1270.000	168.380	825	S377	270.000	168.380	875	S327	-730.000	168.380
776	S426	1250.000	293.380	826	S376	250.000	293.380	876	S326	-750.000	293.380
777	S425	1230.000	168.380	827	S375	230.000	168.380	877	S325	-770.000	168.380
778	S424	1210.000	293.380	828	S374	210.000	293.380	878	S324	-790.000	293.380
779	S423	1190.000	168.380	829	S373	190.000	168.380	879	S323	-810.000	168.380
780	S422	1170.000	293.380	830	S372	170.000	293.380	880	S322	-830.000	293.380
781	S421	1150.000	168.380	831	S371	150.000	168.380	881	S321	-850.000	168.380
782	S420	1130.000	293.380	832	S370	130.000	293.380	882	S320	-870.000	293.380
783	S419	1110.000	168.380	833	S369	110.000	168.380	883	S319	-890.000	168.380
784	S418	1090.000	293.380	834	S368	90.000	293.380	884	S318	-910.000	293.380
785	S417	1070.000	168.380	835	S367	70.000	168.380	885	S317	-930.000	168.380
786	S416	1050.000	293.380	836	S366	50.000	293.380	886	S316	-950.000	293.380
787	S415	1030.000	168.380	837	S365	30.000	168.380	887	S315	-970.000	168.380
788	S414	1010.000	293.380	838	S364	10.000	293.380	888	S314	-990.000	293.380
789	S413	990.000	168.380	839	S363	-10.000	168.380	889	S313	-1010.000	168.380
790	S412	970.000	293.380	840	S362	-30.000	293.380	890	S312	-1030.000	293.380
791	S411	950.000	168.380	841	S361	-50.000	168.380	891	S311	-1050.000	168.380
792	S410	930.000	293.380	842	S360	-70.000	293.380	892	S310	-1070.000	293.380
793	S409	910.000	168.380	843	S359	-90.000	168.380	893	S309	-1090.000	168.380
794	S408	890.000	293.380	844	S358	-110.000	293.380	894	S308	-1110.000	293.380
795	S407	870.000	168.380	845	S357	-130.000	168.380	895	S307	-1130.000	168.380
796	S406	850.000	293.380	846	S356	-150.000	293.380	896	S306	-1150.000	293.380
797	S405	830.000	168.380	847	S355	-170.000	168.380	897	S305	-1170.000	168.380
798	S404	810.000	293.380	848	S354	-190.000	293.380	898	S304	-1190.000	293.380
799	S403	790.000	168.380	849	S353	-210.000	168.380	899	S303	-1210.000	168.380
800	S402	770.000	293.380	850	S352	-230.000	293.380	900	S302	-1230.000	293.380

Pad #	Pad Name	X-pos	Y-pos	Pad #	Pad Name	X-pos	Y-pos	Pad #	Pad Name	X-pos	Y-pos
901	S301	-1250.000	168.380	951	S251	-2250.000	168.380	1001	S201	-3250.000	168.380
902	S300	-1270.000	293.380	952	S250	-2270.000	293.380	1002	S200	-3270.000	293.380
903	S299	-1290.000	168.380	953	S249	-2290.000	168.380	1003	S199	-3290.000	168.380
904	S298	-1310.000	293.380	954	S248	-2310.000	293.380	1004	S198	-3310.000	293.380
905	S297	-1330.000	168.380	955	S247	-2330.000	168.380	1005	S197	-3330.000	168.380
906	S296	-1350.000	293.380	956	S246	-2350.000	293.380	1006	S196	-3350.000	293.380
907	S295	-1370.000	168.380	957	S245	-2370.000	168.380	1007	S195	-3370.000	168.380
908	S294	-1390.000	293.380	958	S244	-2390.000	293.380	1008	S194	-3390.000	293.380
909	S293	-1410.000	168.380	959	S243	-2410.000	168.380	1009	S193	-3410.000	168.380
910	S292	-1430.000	293.380	960	S242	-2430.000	293.380	1010	S192	-3430.000	293.380
911	S291	-1450.000	168.380	961	S241	-2450.000	168.380	1011	S191	-3450.000	168.380
912	S290	-1470.000	293.380	962	S240	-2470.000	293.380	1012	S190	-3470.000	293.380
913	S289	-1490.000	168.380	963	S239	-2490.000	168.380	1013	S189	-3490.000	168.380
914	S288	-1510.000	293.380	964	S238	-2510.000	293.380	1014	S188	-3510.000	293.380
915	S287	-1530.000	168.380	965	S237	-2530.000	168.380	1015	S187	-3530.000	168.380
916	S286	-1550.000	293.380	966	S236	-2550.000	293.380	1016	S186	-3550.000	293.380
917	S285	-1570.000	168.380	967	S235	-2570.000	168.380	1017	S185	-3570.000	168.380
918	S284	-1590.000	293.380	968	S234	-2590.000	293.380	1018	S184	-3590.000	293.380
919	S283	-1610.000	168.380	969	S233	-2610.000	168.380	1019	S183	-3610.000	168.380
920	S282	-1630.000	293.380	970	S232	-2630.000	293.380	1020	S182	-3630.000	293.380
921	S281	-1650.000	168.380	971	S231	-2650.000	168.380	1021	S181	-3650.000	168.380
922	S280	-1670.000	293.380	972	S230	-2670.000	293.380	1022	S180	-3670.000	293.380
923	S279	-1690.000	168.380	973	S229	-2690.000	168.380	1023	S179	-3690.000	168.380
924	S278	-1710.000	293.380	974	S228	-2710.000	293.380	1024	S178	-3710.000	293.380
925	S277	-1730.000	168.380	975	S227	-2730.000	168.380	1025	S177	-3730.000	168.380
926	S276	-1750.000	293.380	976	S226	-2750.000	293.380	1026	S176	-3750.000	293.380
927	S275	-1770.000	168.380	977	S225	-2770.000	168.380	1027	S175	-3770.000	168.380
928	S274	-1790.000	293.380	978	S224	-2790.000	293.380	1028	S174	-3790.000	293.380
929	S273	-1810.000	168.380	979	S223	-2810.000	168.380	1029	S173	-3810.000	168.380
930	S272	-1830.000	293.380	980	S222	-2830.000	293.380	1030	S172	-3830.000	293.380
931	S271	-1850.000	168.380	981	S221	-2850.000	168.380	1031	S171	-3850.000	168.380
932	S270	-1870.000	293.380	982	S220	-2870.000	293.380	1032	S170	-3870.000	293.380
933	S269	-1890.000	168.380	983	S219	-2890.000	168.380	1033	S169	-3890.000	168.380
934	S268	-1910.000	293.380	984	S218	-2910.000	293.380	1034	S168	-3910.000	293.380
935	S267	-1930.000	168.380	985	S217	-2930.000	168.380	1035	S167	-3930.000	168.380
936	S266	-1950.000	293.380	986	S216	-2950.000	293.380	1036	S166	-3950.000	293.380
937	S265	-1970.000	168.380	987	S215	-2970.000	168.380	1037	S165	-3970.000	168.380
938	S264	-1990.000	293.380	988	S214	-2990.000	293.380	1038	S164	-3990.000	293.380
939	S263	-2010.000	168.380	989	S213	-3010.000	168.380	1039	S163	-4010.000	168.380
940	S262	-2030.000	293.380	990	S212	-3030.000	293.380	1040	S162	-4030.000	293.380
941	S261	-2050.000	168.380	991	S211	-3050.000	168.380	1041	S161	-4050.000	168.380
942	S260	-2070.000	293.380	992	S210	-3070.000	293.380	1042	S160	-4070.000	293.380
943	S259	-2090.000	168.380	993	S209	-3090.000	168.380	1043	S159	-4090.000	168.380
944	S258	-2110.000	293.380	994	S208	-3110.000	293.380	1044	S158	-4110.000	293.380
945	S257	-2130.000	168.380	995	S207	-3130.000	168.380	1045	S157	-4130.000	168.380
946	S256	-2150.000	293.380	996	S206	-3150.000	293.380	1046	S156	-4150.000	293.380
947	S255	-2170.000	168.380	997	S205	-3170.000	168.380	1047	S155	-4170.000	168.380
948	S254	-2190.000	293.380	998	S204	-3190.000	293.380	1048	S154	-4190.000	293.380
949	S253	-2210.000	168.380	999	S203	-3210.000	168.380	1049	S153	-4210.000	168.380
950	S252	-2230.000	293.380	1000	S202	-3230.000	293.380	1050	S152	-4230.000	293.380

Pad #	Pad Name	X-pos	Y-pos	Pad #	Pad Name	X-pos	Y-pos	Pad #	Pad Name	X-pos	Y-pos
1051	S151	-4250.000	168.380	1101	S101	-5250.000	168.380	1151	S51	-6250.000	168.380
1052	S150	-4270.000	293.380	1102	S100	-5270.000	293.380	1152	S50	-6270.000	293.380
1053	S149	-4290.000	168.380	1103	S99	-5290.000	168.380	1153	S49	-6290.000	168.380
1054	S148	-4310.000	293.380	1104	S98	-5310.000	293.380	1154	S48	-6310.000	293.380
1055	S147	-4330.000	168.380	1105	S97	-5330.000	168.380	1155	S47	-6330.000	168.380
1056	S146	-4350.000	293.380	1106	S96	-5350.000	293.380	1156	S46	-6350.000	293.380
1057	S145	-4370.000	168.380	1107	S95	-5370.000	168.380	1157	S45	-6370.000	168.380
1058	S144	-4390.000	293.380	1108	S94	-5390.000	293.380	1158	S44	-6390.000	293.380
1059	S143	-4410.000	168.380	1109	S93	-5410.000	168.380	1159	S43	-6410.000	168.380
1060	S142	-4430.000	293.380	1110	S92	-5430.000	293.380	1160	S42	-6430.000	293.380
1061	S141	-4450.000	168.380	1111	S91	-5450.000	168.380	1161	S41	-6450.000	168.380
1062	S140	-4470.000	293.380	1112	S90	-5470.000	293.380	1162	S40	-6470.000	293.380
1063	S139	-4490.000	168.380	1113	S89	-5490.000	168.380	1163	S39	-6490.000	168.380
1064	S138	-4510.000	293.380	1114	S88	-5510.000	293.380	1164	S38	-6510.000	293.380
1065	S137	-4530.000	168.380	1115	S87	-5530.000	168.380	1165	S37	-6530.000	168.380
1066	S136	-4550.000	293.380	1116	S86	-5550.000	293.380	1166	S36	-6550.000	293.380
1067	S135	-4570.000	168.380	1117	S85	-5570.000	168.380	1167	S35	-6570.000	168.380
1068	S134	-4590.000	293.380	1118	S84	-5590.000	293.380	1168	S34	-6590.000	293.380
1069	S133	-4610.000	168.380	1119	S83	-5610.000	168.380	1169	S33	-6610.000	168.380
1070	S132	-4630.000	293.380	1120	S82	-5630.000	293.380	1170	S32	-6630.000	293.380
1071	S131	-4650.000	168.380	1121	S81	-5650.000	168.380	1171	S31	-6650.000	168.380
1072	S130	-4670.000	293.380	1122	S80	-5670.000	293.380	1172	S30	-6670.000	293.380
1073	S129	-4690.000	168.380	1123	S79	-5690.000	168.380	1173	S29	-6690.000	168.380
1074	S128	-4710.000	293.380	1124	S78	-5710.000	293.380	1174	S28	-6710.000	293.380
1075	S127	-4730.000	168.380	1125	S77	-5730.000	168.380	1175	S27	-6730.000	168.380
1076	S126	-4750.000	293.380	1126	S76	-5750.000	293.380	1176	S26	-6750.000	293.380
1077	S125	-4770.000	168.380	1127	S75	-5770.000	168.380	1177	S25	-6770.000	168.380
1078	S124	-4790.000	293.380	1128	S74	-5790.000	293.380	1178	S24	-6790.000	293.380
1079	S123	-4810.000	168.380	1129	S73	-5810.000	168.380	1179	S23	-6810.000	168.380
1080	S122	-4830.000	293.380	1130	S72	-5830.000	293.380	1180	S22	-6830.000	293.380
1081	S121	-4850.000	168.380	1131	S71	-5850.000	168.380	1181	S21	-6850.000	168.380
1082	S120	-4870.000	293.380	1132	S70	-5870.000	293.380	1182	S20	-6870.000	293.380
1083	S119	-4890.000	168.380	1133	S69	-5890.000	168.380	1183	S19	-6890.000	168.380
1084	S118	-4910.000	293.380	1134	S68	-5910.000	293.380	1184	S18	-6910.000	293.380
1085	S117	-4930.000	168.380	1135	S67	-5930.000	168.380	1185	S17	-6930.000	168.380
1086	S116	-4950.000	293.380	1136	S66	-5950.000	293.380	1186	S16	-6950.000	293.380
1087	S115	-4970.000	168.380	1137	S65	-5970.000	168.380	1187	S15	-6970.000	168.380
1088	S114	-4990.000	293.380	1138	S64	-5990.000	293.380	1188	S14	-6990.000	293.380
1089	S113	-5010.000	168.380	1139	S63	-6010.000	168.380	1189	S13	-7010.000	168.380
1090	S112	-5030.000	293.380	1140	S62	-6030.000	293.380	1190	S12	-7030.000	293.380
1091	S111	-5050.000	168.380	1141	S61	-6050.000	168.380	1191	S11	-7050.000	168.380
1092	S110	-5070.000	293.380	1142	S60	-6070.000	293.380	1192	S10	-7070.000	293.380
1093	S109	-5090.000	168.380	1143	S59	-6090.000	168.380	1193	S9	-7090.000	168.380
1094	S108	-5110.000	293.380	1144	S58	-6110.000	293.380	1194	S8	-7110.000	293.380
1095	S107	-5130.000	168.380	1145	S57	-6130.000	168.380	1195	S7	-7130.000	168.380
1096	S106	-5150.000	293.380	1146	S56	-6150.000	293.380	1196	S6	-7150.000	293.380
1097	S105	-5170.000	168.380	1147	S55	-6170.000	168.380	1197	S5	-7170.000	168.380
1098	S104	-5190.000	293.380	1148	S54	-6190.000	293.380	1198	S4	-7190.000	293.380
1099	S103	-5210.000	168.380	1149	S53	-6210.000	168.380	1199	S3	-7210.000	168.380
1100	S102	-5230.000	293.380	1150	S52	-6230.000	293.380	1200	S2	-7230.000	293.380

Pad #	Pad Name	X-pos	Y-pos	Pad #	Pad Name	X-pos	Y-pos	Pad #	Pad Name	X-pos	Y-pos
1201	S1	-7250.000	168.380	1251	G228	-8290.000	168.380	1301	G128	-9290.000	168.380
1202	S0	-7270.000	293.380	1252	G226	-8310.000	293.380	1302	G126	-9310.000	293.380
1203	LSENIN7	-7330.000	168.380	1253	G224	-8330.000	168.380	1303	G124	-9330.000	168.380
1204	LSENIN8	-7350.000	293.380	1254	G222	-8350.000	293.380	1304	G122	-9350.000	293.380
1205	LSENIN9	-7370.000	168.380	1255	G220	-8370.000	168.380	1305	G120	-9370.000	168.380
1206	G318	-7390.000	293.380	1256	G218	-8390.000	293.380	1306	G118	-9390.000	293.380
1207	G316	-7410.000	168.380	1257	G216	-8410.000	168.380	1307	G116	-9410.000	168.380
1208	G314	-7430.000	293.380	1258	G214	-8430.000	293.380	1308	G114	-9430.000	293.380
1209	G312	-7450.000	168.380	1259	G212	-8450.000	168.380	1309	G112	-9450.000	168.380
1210	G310	-7470.000	293.380	1260	G210	-8470.000	293.380	1310	G110	-9470.000	293.380
1211	G308	-7490.000	168.380	1261	G208	-8490.000	168.380	1311	G108	-9490.000	168.380
1212	G306	-7510.000	293.380	1262	G206	-8510.000	293.380	1312	G106	-9510.000	293.380
1213	G304	-7530.000	168.380	1263	G204	-8530.000	168.380	1313	G104	-9530.000	168.380
1214	G302	-7550.000	293.380	1264	G202	-8550.000	293.380	1314	G102	-9550.000	293.380
1215	G300	-7570.000	168.380	1265	G200	-8570.000	168.380	1315	G100	-9570.000	168.380
1216	G298	-7590.000	293.380	1266	G198	-8590.000	293.380	1316	G98	-9590.000	293.380
1217	G296	-7610.000	168.380	1267	G196	-8610.000	168.380	1317	G96	-9610.000	168.380
1218	G294	-7630.000	293.380	1268	G194	-8630.000	293.380	1318	G94	-9630.000	293.380
1219	G292	-7650.000	168.380	1269	G192	-8650.000	168.380	1319	G92	-9650.000	168.380
1220	G290	-7670.000	293.380	1270	G190	-8670.000	293.380	1320	G90	-9670.000	293.380
1221	G288	-7690.000	168.380	1271	G188	-8690.000	168.380	1321	G88	-9690.000	168.380
1222	G286	-7710.000	293.380	1272	G186	-8710.000	293.380	1322	G86	-9710.000	293.380
1223	G284	-7730.000	168.380	1273	G184	-8730.000	168.380	1323	G84	-9730.000	168.380
1224	G282	-7750.000	293.380	1274	G182	-8750.000	293.380	1324	G82	-9750.000	293.380
1225	G280	-7770.000	168.380	1275	G180	-8770.000	168.380	1325	G80	-9770.000	168.380
1226	G278	-7790.000	293.380	1276	G178	-8790.000	293.380	1326	G78	-9790.000	293.380
1227	G276	-7810.000	168.380	1277	G176	-8810.000	168.380	1327	G76	-9810.000	168.380
1228	G274	-7830.000	293.380	1278	G174	-8830.000	293.380	1328	G74	-9830.000	293.380
1229	G272	-7850.000	168.380	1279	G172	-8850.000	168.380	1329	G72	-9850.000	168.380
1230	G270	-7870.000	293.380	1280	G170	-8870.000	293.380	1330	G70	-9870.000	293.380
1231	G268	-7890.000	168.380	1281	G168	-8890.000	168.380	1331	G68	-9890.000	168.380
1232	G266	-7910.000	293.380	1282	G166	-8910.000	293.380	1332	G66	-9910.000	293.380
1233	G264	-7930.000	168.380	1283	G164	-8930.000	168.380	1333	G64	-9930.000	168.380
1234	G262	-7950.000	293.380	1284	G162	-8950.000	293.380	1334	G62	-9950.000	293.380
1235	G260	-7970.000	168.380	1285	G160	-8970.000	168.380	1335	G60	-9970.000	168.380
1236	G258	-7990.000	293.380	1286	G158	-8990.000	293.380	1336	G58	-9990.000	293.380
1237	G256	-8010.000	168.380	1287	G156	-9010.000	168.380	1337	G56	-10010.000	168.380
1238	G254	-8030.000	293.380	1288	G154	-9030.000	293.380	1338	G54	-10030.000	293.380
1239	G252	-8050.000	168.380	1289	G152	-9050.000	168.380	1339	G52	-10050.000	168.380
1240	G250	-8070.000	293.380	1290	G150	-9070.000	293.380	1340	G50	-10070.000	293.380
1241	G248	-8090.000	168.380	1291	G148	-9090.000	168.380	1341	G48	-10090.000	168.380
1242	G246	-8110.000	293.380	1292	G146	-9110.000	293.380	1342	G46	-10110.000	293.380
1243	G244	-8130.000	168.380	1293	G144	-9130.000	168.380	1343	G44	-10130.000	168.380
1244	G242	-8150.000	293.380	1294	G142	-9150.000	293.380	1344	G42	-10150.000	293.380
1245	G240	-8170.000	168.380	1295	G140	-9170.000	168.380	1345	G40	-10170.000	168.380
1246	G238	-8190.000	293.380	1296	G138	-9190.000	293.380	1346	G38	-10190.000	293.380
1247	G236	-8210.000	168.380	1297	G136	-9210.000	168.380	1347	G36	-10210.000	168.380
1248	G234	-8230.000	293.380	1298	G134	-9230.000	293.380	1348	G34	-10230.000	293.380
1249	G232	-8250.000	168.380	1299	G132	-9250.000	168.380	1349	G32	-10250.000	168.380
1250	G230	-8270.000	293.380	1300	G130	-9270.000	293.380	1350	G30	-10270.000	293.380

Pad #	Pad Name	X-pos	Y-pos
1351	G28	-10290.000	168.380
1352	G26	-10310.000	293.380
1353	G24	-10330.000	168.380
1354	G22	-10350.000	293.380
1355	G20	-10370.000	168.380
1356	G18	-10390.000	293.380
1357	G16	-10410.000	168.380
1358	G14	-10430.000	293.380
1359	G12	-10450.000	168.380
1360	G10	-10470.000	293.380
1361	G8	-10490.000	168.380
1362	G6	-10510.000	293.380
1363	G4	-10530.000	168.380
1364	G2	-10550.000	293.380
1365	G0	-10570.000	168.380
1366	LSENIN10	-10590.000	293.380
1367	LSENIN11	-10610.000	168.380
1368	LSENIN12	-10630.000	293.380
1369	DUMMY	-10650.000	168.380
1370	DUMMY	-10670.000	293.380
1371	DUMMY	-10690.000	168.380
1372	DUMMY	-10710.000	293.380

Confidential

6 PIN DESCRIPTIONS

Key:

- I = Input
- O = Output
- IO = Bi-directional (input/output)
- P = Power pin

Table 6-1: Power Supply Pins

Pin Name	Type	Connect to	Function	Description	When not in use
V _{SS}	P	GND	Ground of Power Supply	System ground pin of the IC.	-
AV _{SS}		GND		Grounding for analog circuit.	-
V _{SSRC}		GND		Grounding for analog circuit. This pin requires a noise free path for providing accurate LCD driving voltages.	-
IOGND		GND		Grounding for logic I/O.	-
V _{CHS}		GND		Grounding for booster circuit.	-
V _{CORE}	P	V _{REGC}	Power Supply for Core Logic	V _{DD} for core use	-
V _{DDIO}		System V _{DD}	Power Supply for Interface Logic Pins	Voltage input pin for logic I/O.	-
DV _{DDM}		V _{REGCM}	Power Supply for MIPI Logic	Voltage supply for MIPI logic circuit.	-
AV _{DDM}		V _{REGCM}	Power Supply for MIPI Analog Circuit	Voltage supply for MIPI analog circuit.	-
V _{CI}	P	Power Supply	Power Supply for Analog Circuits	Booster input voltage pin. - Connect to voltage source between 2.5V to 3.6V	-
V _{CIR}		Power supply		Voltage supply pin for regulator circuit. - Connect to same source of V _{CI}	-
V _{CIP}		V _{CI}		Voltage supply pin for analog circuit. This pin requires a noise free path for providing accurate LCD driving voltages. - Connect to same source of V _{CI}	-
HC		V _{SS}		- Connect to V _{SS}	-
V _{REGC}	O	Stabilizing capacitor	Regulated Voltage	Regulator output for V _{CORE} use..	-
V _{REGCM}	O	Stabilizing capacitor	Regulated Voltage	Regulator output for MIPI logic circuit.	-
V _{CIM}	O	Stabilizing capacitor	Booster Voltages	Negative voltage of V _{CI} .	-
V _{CIX2}		Stabilizing capacitor		Equals to or less than 2 × V _{CI}	-
V _{CIX2G}	P	V _{CIX2} on FPC	Power Supply for Analog Circuits	Power supply used by on chip analog blocks and V _{GH} /V _{GL} dcde. Must connect V _{CIX2} together	-

Pin Name	Type	Connect to	Function	Description	When not in use
V _{COMR}	P	External voltage source or Open	External Reference	This pin provides voltage reference for internal voltage regulator when register VDV[4:0] of Power Control 4 set to "01111". - Connect to an external voltage source for reference	Open
V _{COMH}	O	Stabilizing capacitor	Voltages for VCOM Signal	This pin indicates a HIGH level of VCOM generated in driving the VCOM alternation.	-
V _{COML}		Stabilizing capacitor		This pin indicates a LOW level of VCOM generated in driving the VCOM alternation.	-
V _{LCD255}	O	Stabilizing capacitor	LCD Driving Voltages	This pin is the maximum source driver voltage.	-
V _{GH}		Stabilizing capacitor		A positive voltage output pin for gate driver.	-
V _{GL}		Stabilizing capacitor		A negative voltage output pin for gate driver.	-
EXVR	I	GND	External Reference	External reference of internal gamma resistor - Connect to V _{SS}	-
CXP	I	Booster capacitor	Booster and Stabilization Capacitors	- Connect a capacitor to CXN	-
CXN				- Connect a capacitor to CXP	-
CYP		Booster capacitor		- Connect a capacitor to CYN	-
CYN				- Connect a capacitor to CYP	-
C1P		Booster capacitor		- Connect a capacitor to C1N	-
C1N				- Connect a capacitor to C1P	-
C2P		Booster capacitor		- Connect a capacitor to C2N	-
C2N				- Connect a capacitor to C2P	-
C3P		Booster capacitor		- Connect a capacitor to C3N	-
C3N				- Connect a capacitor to C3P	-
CDUM0	I	Stabilizing capacitor	Charge Sharing Capacitors	- Connect a capacitor to V _{SS}	Open
CSVCMN		Stabilizing capacitor		- Connect a capacitor to CSVCMN	Open
CSVCMN		Stabilizing capacitor		- Connect a capacitor to CSVCMN	Open

Table 6-2 - Interface Logic Pins

Name	Type	Connect to	Function	Description	When not in use
SDC	I	MPU	Logic Control	Data or command	V _{DDIO} or V _{SS}
\overline{CS}		MPU		Chip select pin for SPI interface	-
\overline{RES}	I	MPU	System Reset	System reset pin. - An active low pulse at this pin will reset the IC, Connect to V _{DDIO} in normal operation	-
SCK	I	MPU	Serial interface	Clock input pin in serial interface.	V _{SS}
SDI		MPU		Data iutput pin in serial interface	V _{SS}
SDO	O	MPU		Data output pin in serial interface	Open
SPID	I	MPU		Serial Data ID	V _{DDIO} or V _{SS}

Table 6-3: MIPI Pins

Name	Type	Connect to	Function	Description	When not in use
DATAP	IO	MIPI Interface Signal	MIPI differential Data Pair	Positive polarity of low voltage differential data signal	-
DATAN				Negative polarity of low voltage differential data signal	-
CLKP	I		MIPI differential Clock Pair	Positive polarity of low voltage differential clock signal	-
CLKN	I			Negative polarity of low voltage differential clock signal	-
RBCLK	I	External Clock	Clock Input	MIPI read back clock input for MIPI read back mode. External Clock input for MTP program.	Open
APAD	O	Stabilizing capacitor	Test Pin of MIPI Analog circuit	A positive voltage output pin for MIPI analog circuit. - Connect a capacitor to V _{SS}	-

Table 6-4: Mode Selection Pins

Name	Type	Connect to	Function	Description	When not in use												
CM	I	V _{DDIO} or V _{SS}	Logic Control	Input pin to select 16.7M-color or 8-color display mode. After entered 8-color display mode, the driver will switch to Frame-Inversion-Mode, and only MSB of the data Red, Green and Blue will be considered. - Connect to V _{DDIO} for 8-color display mode - Connect to V _{SS} for 16.7M-color display mode	V _{SS}												
STYPE[1:0]	I	V _{DDIO} or V _{SS}	Interface Selection	<table border="1"> <thead> <tr> <th>STYPE1</th> <th>STYPE0</th> <th>Interface Mode</th> </tr> </thead> <tbody> <tr> <td>0</td> <td>x</td> <td>3-wires SPI with 24bits</td> </tr> <tr> <td>1</td> <td>0</td> <td>3-wires SPI with 9bits</td> </tr> <tr> <td>1</td> <td>1</td> <td>4-wires SPI with 8bits</td> </tr> </tbody> </table>	STYPE1	STYPE0	Interface Mode	0	x	3-wires SPI with 24bits	1	0	3-wires SPI with 9bits	1	1	4-wires SPI with 8bits	-
STYPE1	STYPE0	Interface Mode															
0	x	3-wires SPI with 24bits															
1	0	3-wires SPI with 9bits															
1	1	4-wires SPI with 8bits															
GAMAS[1:0]	I	V _{DDIO} or V _{SS}	Logic Control	Gamma selection pin. These pins should be connected to V _{DDIO} / V _{SS}	-												

Table 6-5: Driver Output Pins

Name	Type	Connect to	Function	Description	When not in use
VCOM	O	LCD	LCD Driving Signals	A power supply for the TFT-display common electrode.	Open
G0-G319		LCD		Gate driver output pins. These pins output V _{GH} or V _{GL} level.	Open
S0-S719		LCD		Source driver output pins. S(3n) : display Red if BGR = LOW, Blue if BGR = HIGH. S(3n+1) : display Green. S(3n+2) : display Blue if BGR = LOW, Red if BGR = HIGH.	Open

Table 6-6: Photo sensor Pins

Name	Type	Connect to	Function	Description	When not in use
LSENFBI – LSENFBI9	I	FPC	Sensing Range Adjustment	Please refer to application notes for more details.	-
LSENNI1 – LSENNI12	I	Photo Diodes	Photo Sensor Connection	Please refer to application notes for more details.	-
LSENOU1 – LSENOU3	O			Please refer to application notes for more details.	-
LSENV	P	V _{CIM}	External Reference	External reference of the photo sensor circuit. - Connect to V _{CIM}	-
SENSW	I	V _{DDIO} or V _{SS}	Sensor Mode Selection	Input pin to select Voltage or Current mode of photo sensing circuit. - Connect to V _{DDIO} for voltage sensing mode - Connect to V _{SS} for current sensing mode	-

Table 6-7: Miscellaneous Pins

Name	Type	Connect to	Function	Description	When not in use
NC	-	-	-	These pins must be left open and cannot be connected together	Open
DUMMY	-	-	-	Floating pins and no connection inside the IC. These pins can be shorted together or connect to any signal.	Open
V _{PP}	P	FPC	Power for MTP Program	Please refer to application notes for more details.	-
TESTA	IO	FPC	IC Testing Signals	Test pin of the internal circuit. - Leave this pin open and optional to insert test point in FPC for evaluation.	Open
TESTB		FPC		Test pin of the internal circuit. - Leave this pin open and optional to insert test point in FPC for evaluation.	Open
TESTC		FPC		Test pin of the internal circuit. - Leave this pin open and optional to insert test point in FPC for evaluation.	Open
TEST1~28	IO	-	Testing Signal	Test pin of the internal circuit. - Please refer to application note for pin connection.	-
MFF-G	I	V _{DDIO} or V _{SS}		Please refer to application notes for more details.	V _{SS}
TS	I	V _{DDIO} or V _{SS}	MIPI Test Mode pin	Connect to V _{SS} for normal operation. Connect to V _{DDIO} for test mode.	V _{SS}

7 FUNCTIONAL BLOCK DESCRIPTIONS

7.1 System Interface

TBD

7.2 The MIPI Link

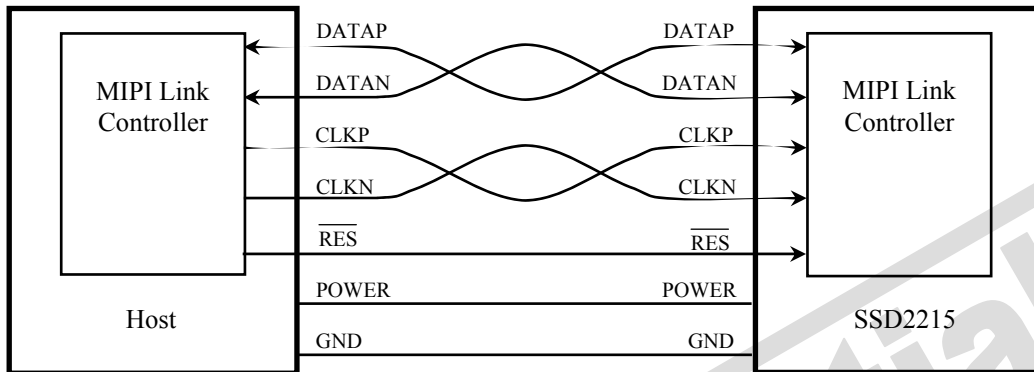

Confidential

7.3 The MIPI Block Structure

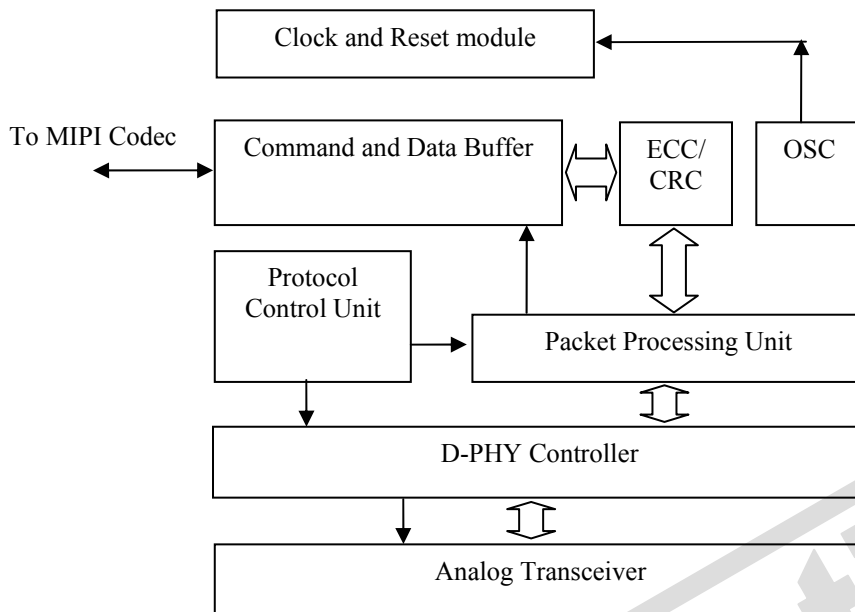

7.4 MIPI controller

7.4.1 D-PHY controller

The D-PHY controller is in charge of the communication with the analog block. During transmission, it receives data and informs the analog transmitter how to transmit. During reception, it receives data from analog receiver and passes the data to the PPU for further processing. At the same time, it is also performing the handshaking process, such as, bus turn around and switching between different modes.

7.4.2 Protocol Control Unit (PCU)

The PCU is in charge of the handling of outgoing and incoming data stream. It has a state machine to decide what packet to be sent when an event comes in and how to react to the received packet.

7.4.3 Packet Processing Unit (PPU)

The PPU is in charge of packet assembly and disassembly. During transmission, it will form the packet according to the instruction from the PCU. During reception, it will extract necessary information from the packet and pass to the PCU.

7.4.4 Error Correction Code/ Cyclic Redundancy Check (ECC/CRC)

During transmission, the ECC/CRC module will generate the ECC or CRC for the outgoing bit stream.

During reception, the ECC/CRC module will check the correctness of the ECC and CRC field of the incoming stream.

If there is 1 bit of error in the data and ECC field, this error will be corrected by the ECC module. If there are more than 1 bit of error in the data and ECC field, the ECC module will detect the error and report it. If there is at least 1 bit of error in the data and CRC field, the CRC module will detect the error and report it.

7.4.5 Internal Data and Command Buffer

The internal data and command buffer is used as temporary storage for incoming command and display data.

For the command buffer, the width is 8 bits. It can hold at most 2 command queues, where each command queue cannot be longer than 8 bytes (including the command itself). The two command queues are sent out alternatively.

For the data buffer, the width is 18/24 bit, which is to accommodate the largest pixel size. The data buffer size is determined by the display window width (maximum size is 240 pixels). It can hold at most 2 lines of display data. They are also sent out alternatively.

7.5 Analog Transceiver

TBD

Confidential

7.6 Gamma/Grayscale Voltage Generator

The grayscale voltage circuit generates a LCD driver circuit that corresponds to the grayscale levels as specified in the grayscale gamma-adjusting resistor. 262K/16.7M possible colors can be displayed when $1 \text{ pixel} = 18/24 \text{ bit}$. For details, see the gamma-adjusting resistor.

7.7 Booster and Regulator Circuit

These two functional blocks generate the voltage of V_{GH} , V_{GL} , V_{COM} levels and V_{LCD255} which are necessary for operating a TFT LCD.

7.8 Oscillation Circuit (OSC)

This module is an On-Chip low power RC oscillator circuitry. The oscillator generates the clock for the DC-DC voltage converter. This clock is also used in the Display Timing Generator.

7.9 Data Latches

This block is a series of latches carrying the display signal information. These latches hold the data, which will be fed to the HV Buffer Cell and Level Selector to output the required voltage level.

Confidential

8 COMMAND TABLE

Table 8-1: Command Table

MIPI COMMAND SET - TBD

Reg#	Register	Direction	IB7	IB6	IB5	IB4	IB3	IB2	IB1	IB0
R39H	enter_idle_mode	NA	NA							
R21H	enter_invert_mode	NA	NA							
R13H	enter_normal_mode	NA	NA							
R10H	enter_sleep_mode	NA	NA							
R38H	exit_idle_mode	NA	NA							
R20H	exit_invert_mode	NA	NA							
R11H	exit_sleep_mode	NA	NA							
R00H	nop	NA	NA							
R28H	set_display_off	NA	NA							
R29H	set_display_on	NA	NA							
R26H	set_gamma_curve	NA	NA							
R3AH	set_pixel_format	H->D	X	D6	D5	D4	X	D2	D1	D0
R01H	soft_reset	NA	NA							

Confidential

SSD2215 Command Set - TBD

Reg#	Register	Direction	IB7	IB6	IB5	IB4	IB3	IB2	IB1	IB0
RB1H	Driver output control	H->D	X	X	X	CAD	X	SM	X	MUX8
		H->D	MUX7	MUX6	MUX5	MUX4	MUX3	MUX2	MUX1	MUX0
RB2H	LCD drive AC control	H->D	0	0	0	FLD	ENWS	B/C	EOR	WSMD
		H->D	NW7	NW6	NW5	NW4	NW3	NW2	NW1	NW0
RB3H	Power control (1)	H->D	DCT3	DCT2	DCT1	DCT0	BT2	BT1	BT0	0
		H->D	DC3	DC2	DC1	DC0	AP2	AP1	AP0	0
RB5H	Compare register (1)	H->D	CPR5	CPR4	CPR3	CPR2	CPR1	CPR0	0	0
		H->D	CPG5	CPG4	CPG3	CPG2	CPG1	CPG0	0	0
RB6H	Compare register (2)	H->D	CPB5	CPB4	CPB3	CPB2	CPB1	CPB0	0	0
RB7H	Display control	H->D	0	0	0	PT1	PT0	X	X	SPT
		H->D	0	0	GON	DTE	X	0	D1	D0
RBBH	Frame cycle control	H->D	NO1	NO0	SDT1	SDT0	0	EQ2	EQ1	EQ0
		H->D	DIV1	DIV0	SDIV	SRTN	RTN3	RTN2	RTN1	RTN0
RBCH	Power control (2)	H->D	0	0	0	0	0	VRC2	VRC1	VRC0
RBDH	Power control (3)	H->D	0	0	0	0	VRH3	VRH2	VRH1	VRH0
RBEH	Power control (4)	H->D	0	0	VCOMG	VDV4	VDV3	VDV2	VDV1	VDV0
RBFH	Gate scan start position	H->D	0	0	0	0	0	0	0	SCN8
		H->D	SCN7	SCN6	SCN5	SCN4	SCN3	SCN2	SCN1	SCN0
RC1H	Entry mode	H->D	VS mode	X	X	TRANS	OEDef	WMode	DMode1	DMode0
		H->D	TY1	TY0	ID1	ID0	AM	LG2	LG1	LG0
RC6H	Horizontal Porch	H->D	XL7	XL6	XL5	XL4	XL3	XL2	XL1	XL0
		H->D	HBP7	HBP6	HBP5	HBP4	HBP3	HBP2	HBP1	HBP0
RC7H	Vertical Porch	H->D	VFP7	VFP6	VFP5	VFP4	VFP3	VFP2	VFP1	VFP0
		H->D	VBP7	VBP6	VBP5	VBP4	VBP3	VBP2	VBP1	VBP0
RCEH	Power control (5)	H->D	nOTP	0	VCM5	VCM4	VCM3	VCM2	VCM1	VCM0
RD3H	RAM write data mask (1)	H->D	WMR5	WMR4	WMR3	WMR2	WMR1	WMR0	0	0
		H->D	WMG5	WMG4	WMG3	WMG2	WMG1	WMG0	0	0
RD4H	RAM write data mask (2)	H->D	WMB5	WMB4	WMB3	WMB2	WMB1	WMB0	0	0
RD5H	Frame Frequency	H->D	OSC3	OSC2	OSC1	OSC0	0	0	0	0
RD8H	VCOM OTP	H->D	0	0	0	0	0	0	0	0
		H->D	0	0	0	0	1	0	1	0
RD9H	VCOM OTP	H->D	1	0	0	0	0	0	0	0
		H->D	1	1	0	0	0	0	0	0
RE0H	γ control (1)	H->D	0	0	0	0	0	PKP12	PKP11	PKP10
		H->D	0	0	0	0	0	PKP02	PKP01	PKP00

Reg#	Register	Direction	IB7	IB6	IB5	IB4	IB3	IB2	IB1	IB0
RE1H	γ control (2)	H->D	0	0	0	0	0	PKP32	PKP31	PKP30
		H->D	0	0	0	0	0	PKP22	PKP21	PKP20
RE2H	γ control (3)	H->D	0	0	0	0	0	PKP52	PKP51	PKP50
		H->D	0	0	0	0	0	PKP42	PKP41	PKP40
RE3H	γ control (4)	H->D	0	0	0	0	0	PRP12	PRP11	PRP10
		H->D	0	0	0	0	0	PRP02	PRP01	PRP00
RE4H	γ control (5)	H->D	0	0	0	0	0	PKN12	PKN11	PKN10
		H->D	0	0	0	0	0	PKN02	PKN01	PKN00
RE5H	γ control (6)	H->D	0	0	0	0	0	PKN32	PKN31	PKN30
		H->D	0	0	0	0	0	PKN22	PKN21	PKN20
RE6H	γ control (7)	H->D	0	0	0	0	0	PKN52	PKN51	PKN50
		H->D	0	0	0	0	0	PKN42	PKN41	PKN40
RE7H	γ control (8)	H->D	0	0	0	0	0	PRN12	PRN11	PRN10
		H->D	0	0	0	0	0	PRN02	PRN01	PRN00
REAH	γ control (9)	H->D	0	0	0	VRP14	VRP13	VRP12	VRP11	VRP10
		H->D	0	0	0	0	VRP03	VRP02	VRP01	VRP00
REBH	γ control (10)	H->D	0	0	0	VRN14	VRN13	VRN12	VRN11	VRN10
		H->D	0	0	0	0	VRN03	VRN02	VRN01	VRN00

Confidential

9 GAMMA ADJUSTMENT FUNCTION

The SSD2215 incorporates gamma adjustment function for the 16M-color display. Gamma adjustment is implemented by deciding the 8-grayscale levels with angle adjustment and micro adjustment register. Also, angle adjustment and micro adjustment is fixed for each of the internal positive and negative polarity.

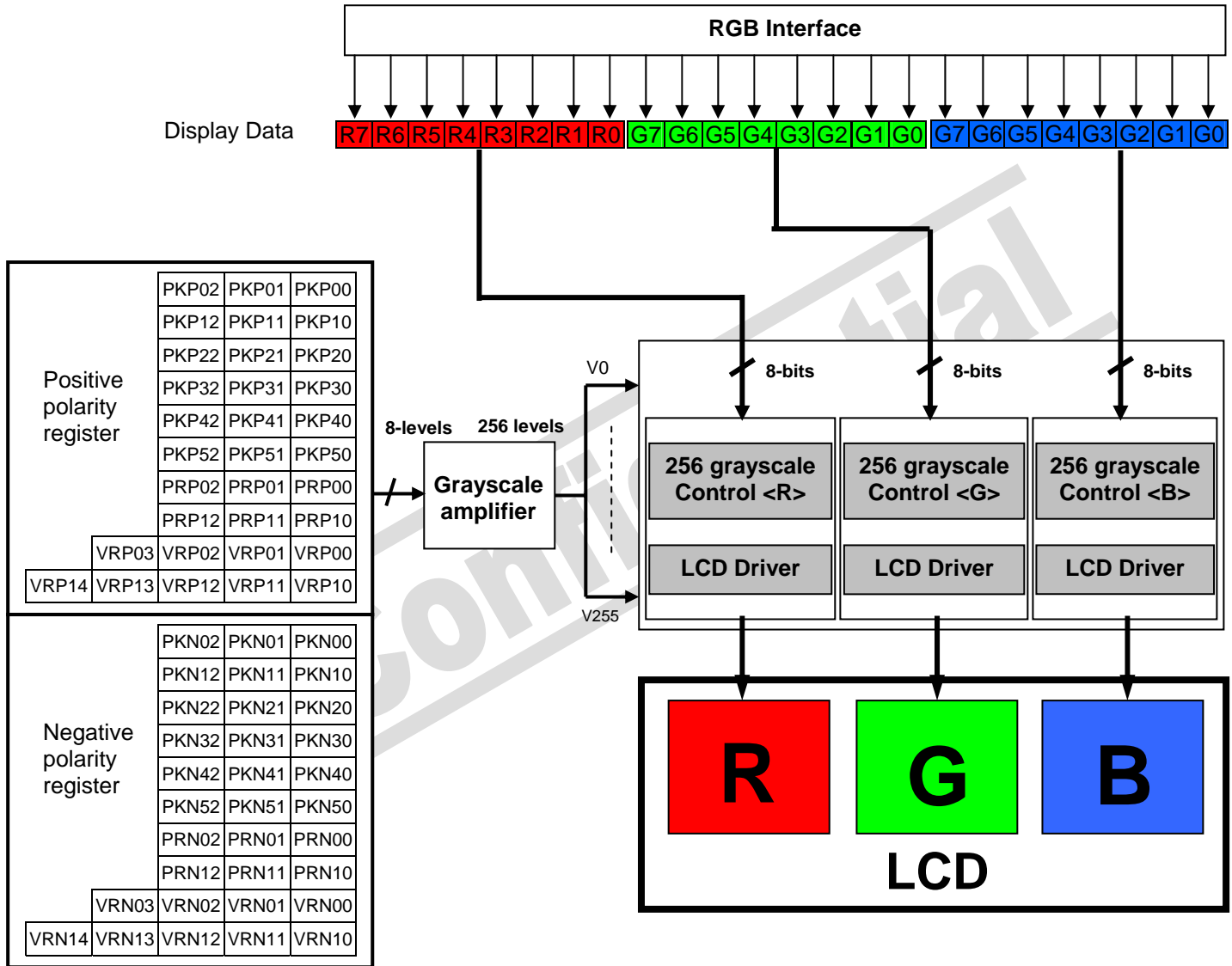

9.1 Structure of Grayscale Amplifier

Below figure indicates the structure of the grayscale amplifier. It determines 8 levels (VIN0-VIN7) by the gradient adjuster and the micro adjustment register. Also, dividing these levels with ladder resistors generates V0 to V255.

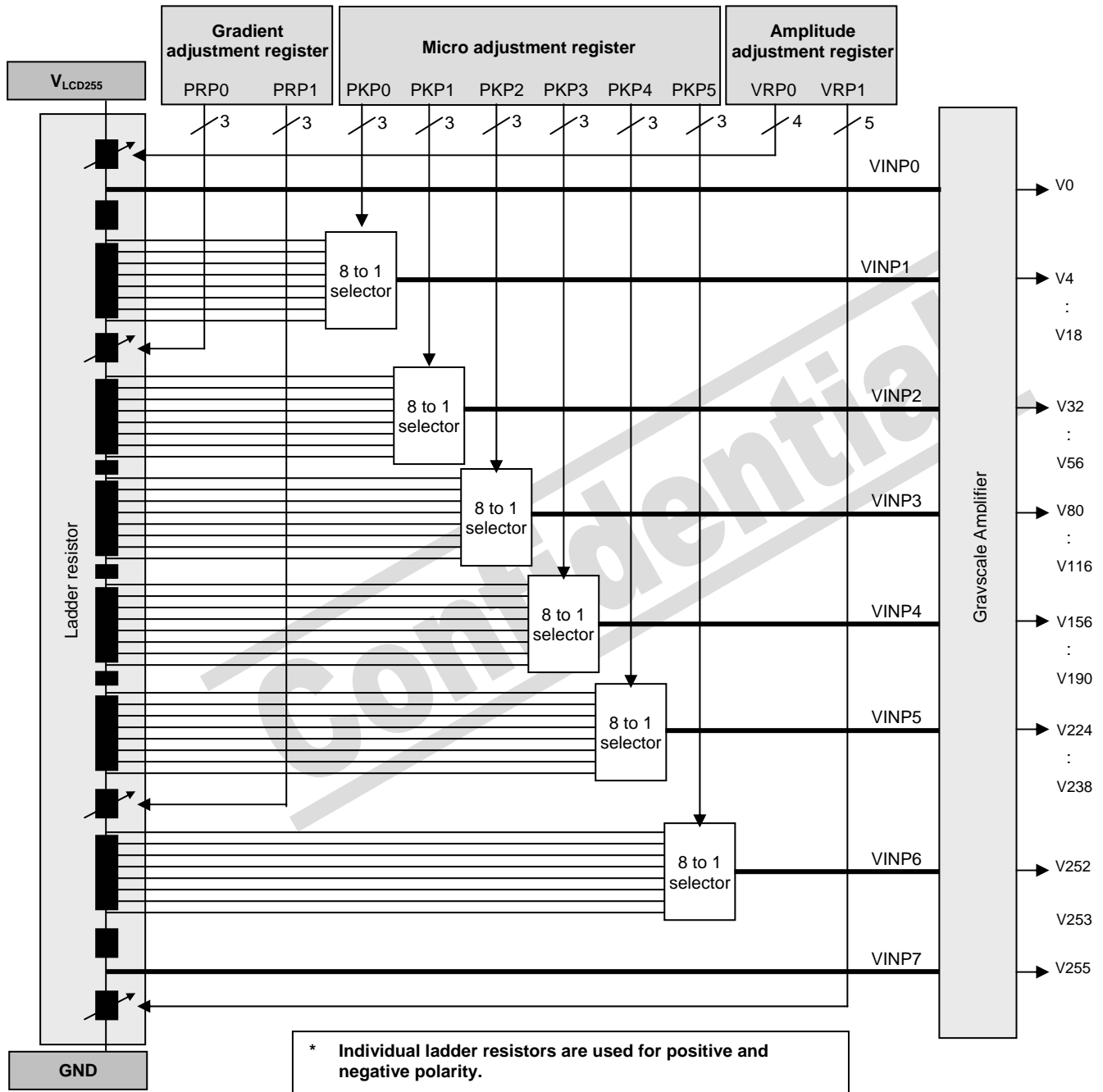

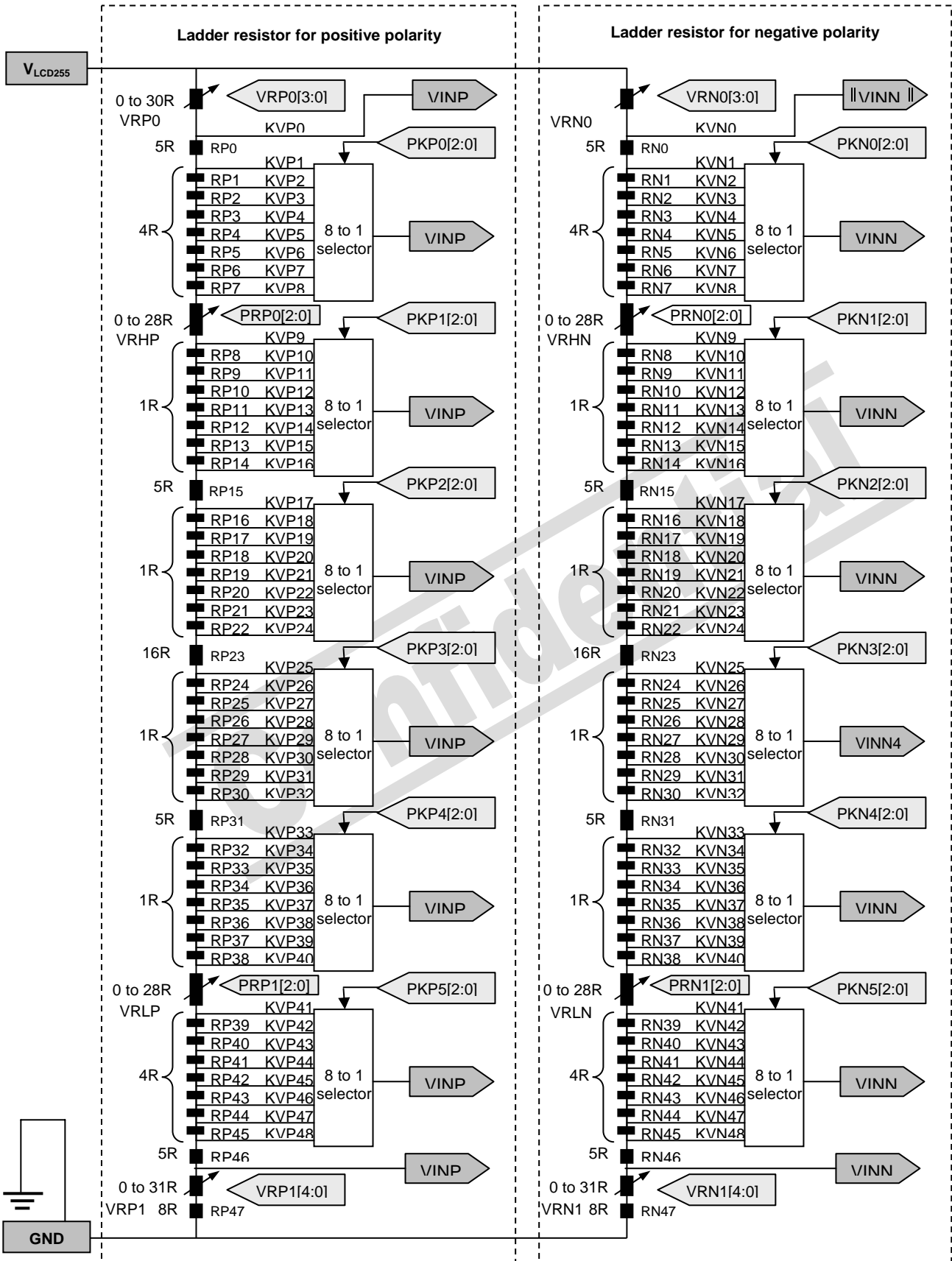

9.2 Separate RGB Gamma Adjustment

Separate RGB Gamma Adjustment is used in SSD2215 where 3 separate resistor ladders are used for defining the RGB source grayscale output voltage instead of single resistor ladder. Each RGB color can be adjusted by its resistor ladder. The RGB gamma curves can be programmed independently and this can be used to adjust for different white balance conditions.

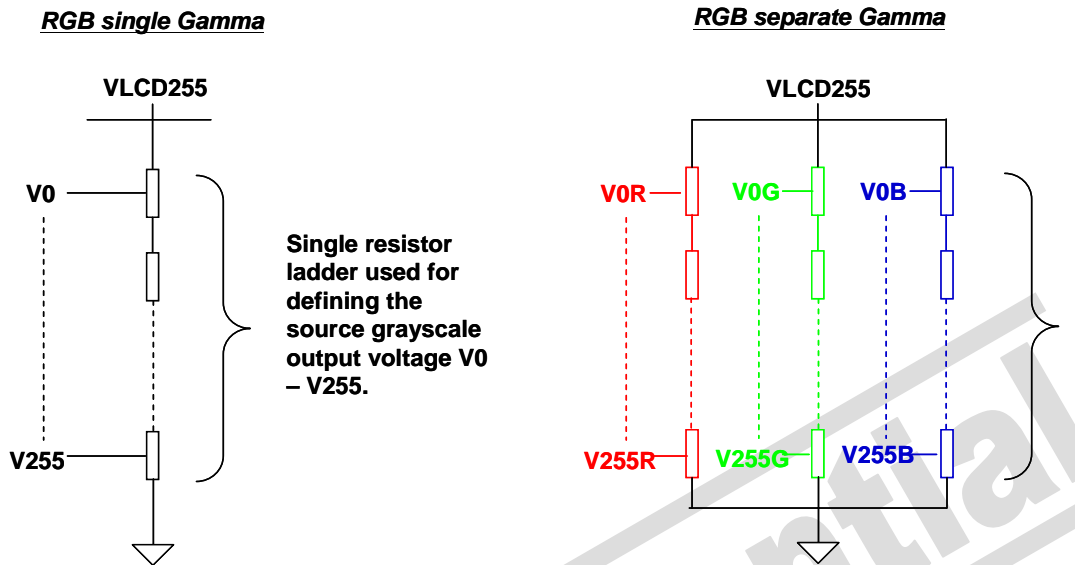

V0 ~ V255 same for RGB

V0 ~ V255 are different for RGB,
 $V0R \neq V0G \neq V0B$, (4.2 ~ 5.0V)
 $V255R \neq V255G \neq V255B$ (0.2 ~ 1.2V)
 (assuming VLCD255 = 5V)

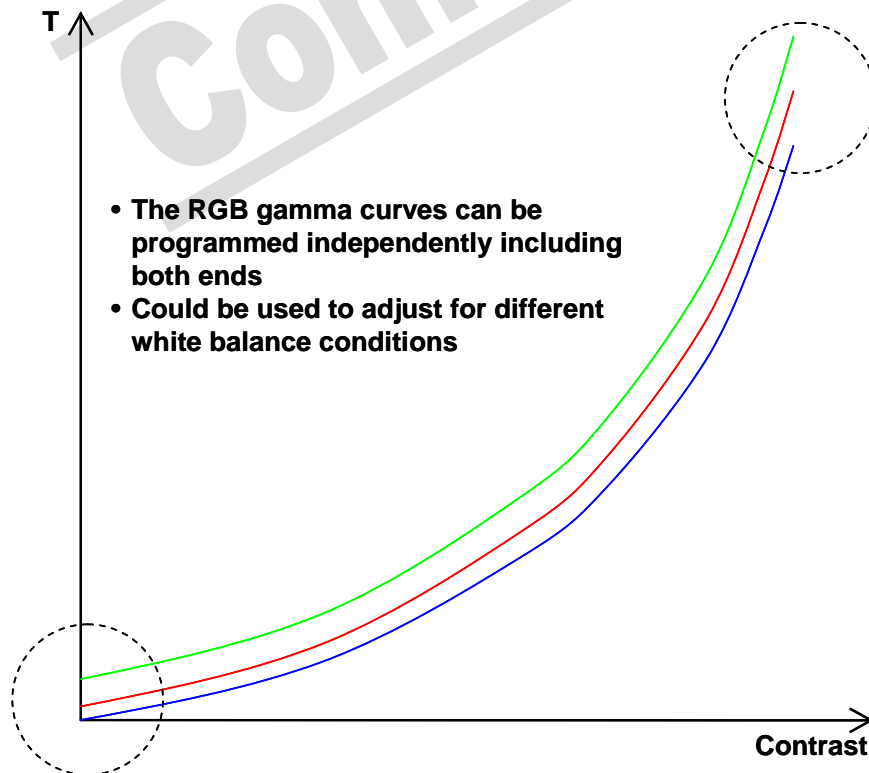

10 APPLICATION CIRCUIT

Figure 10-1: Booster Capacitors

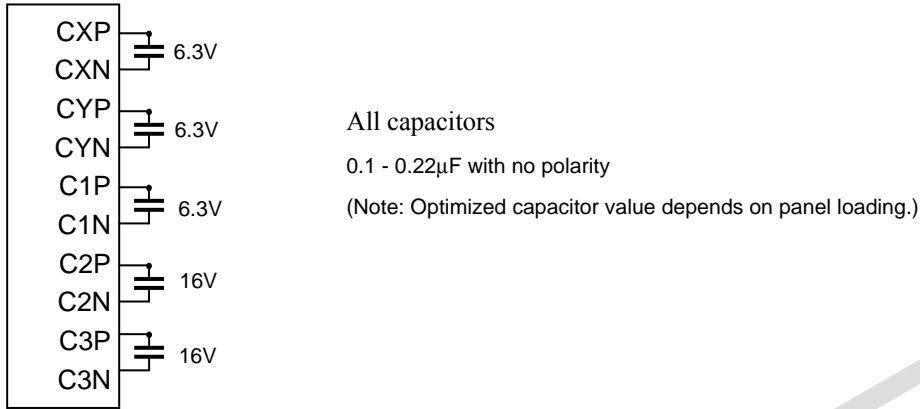

Figure 10-2: Filtering and Charge Sharing Capacitors

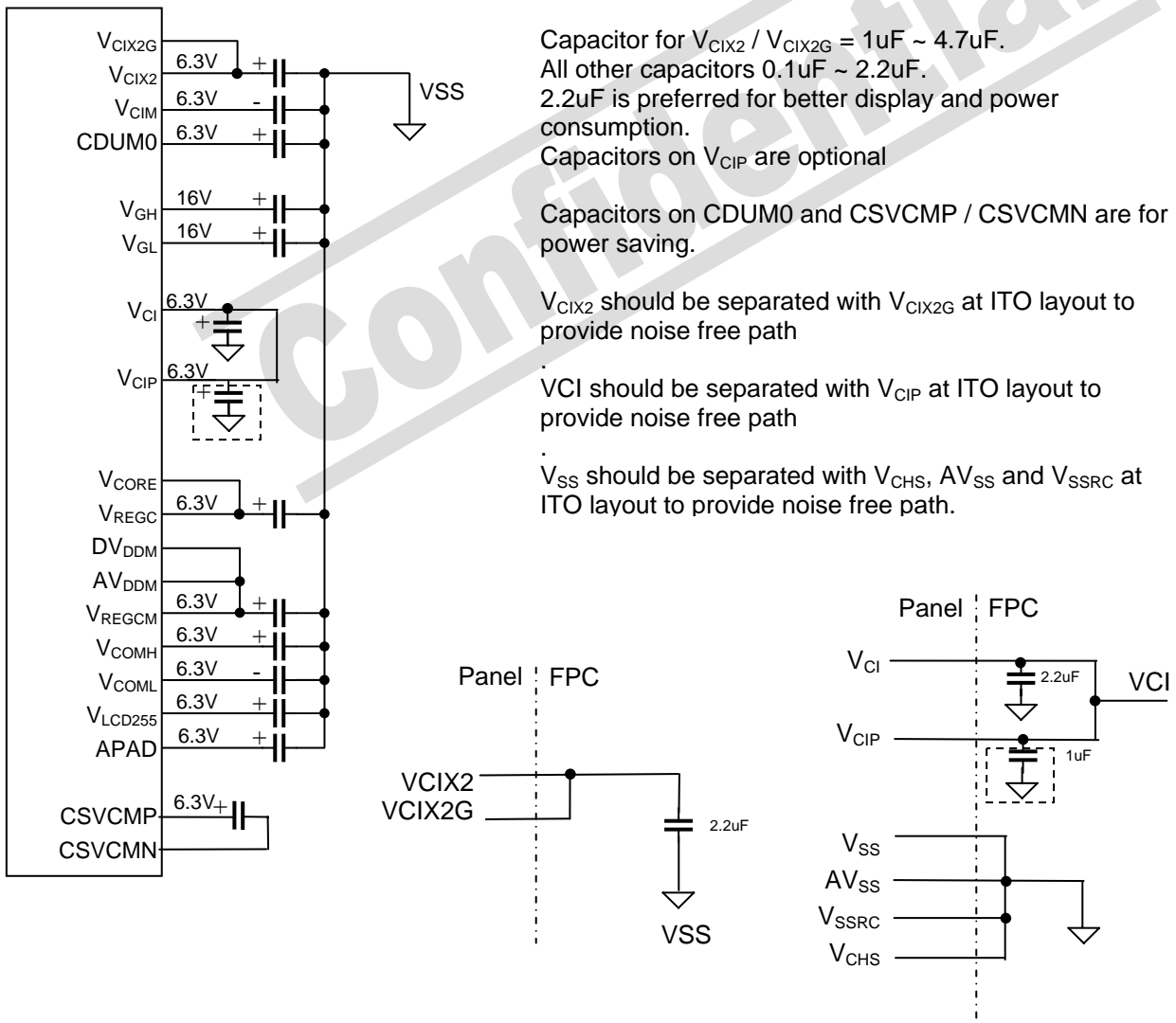
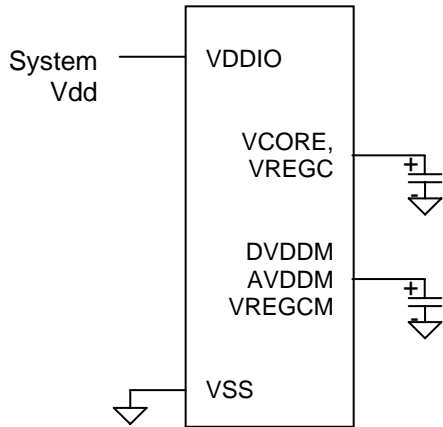

Figure 10-3 - Power Supply Pins Connections (Examples)



Confidential

Figure 10-4 - Application Diagram

SSD2215 control one Main TFT Panel with MIPI and SPI interface

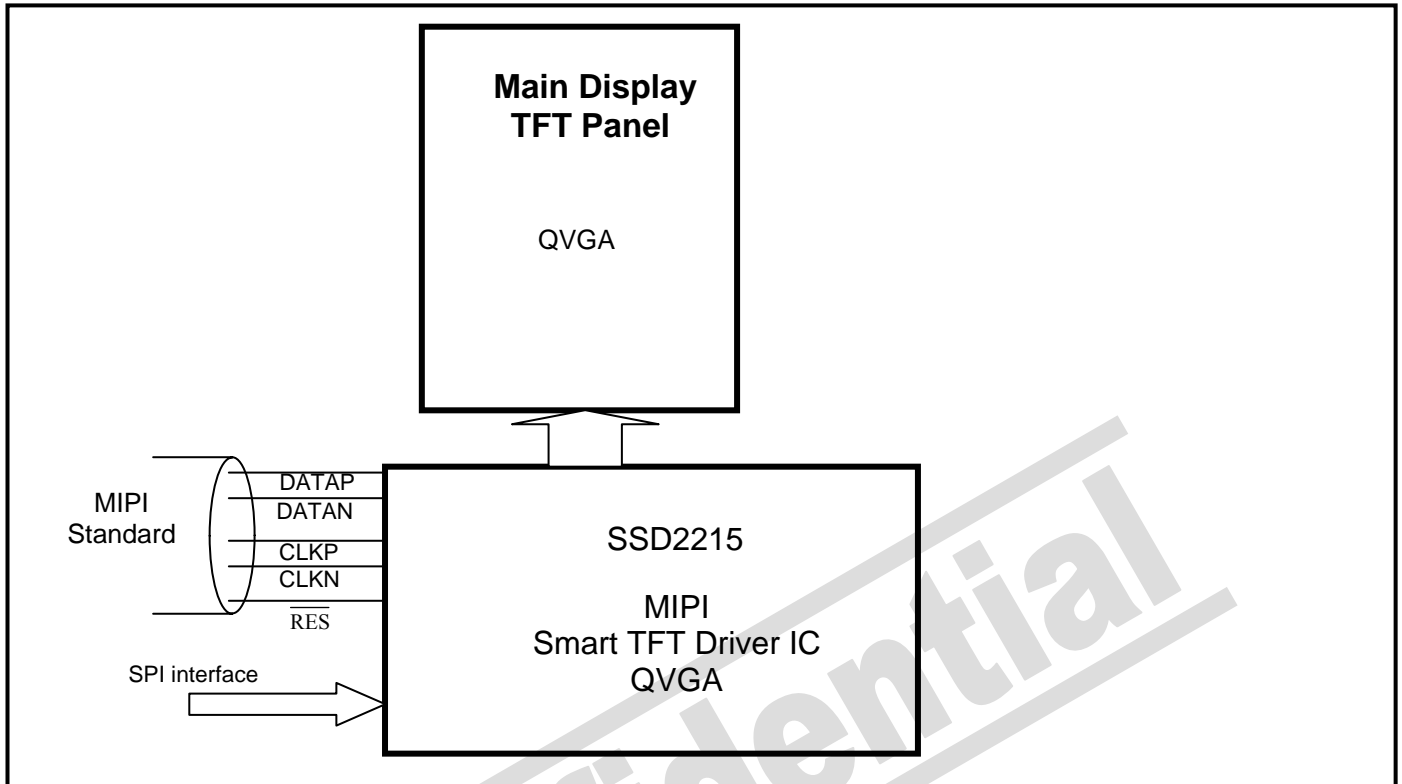

Confidential

Solomon Systech reserves the right to make changes without notice to any products herein. Solomon Systech makes no warranty, representation or guarantee regarding the suitability of its products for any particular purpose, nor does Solomon Systech assume any liability arising out of the application or use of any product or circuit, and specifically disclaims any, and all, liability, including without limitation consequential or incidental damages. "Typical" parameters can and do vary in different applications. All operating parameters, including "Typical" must be validated for each customer application by the customer's technical experts. Solomon Systech does not convey any license under its patent rights nor the rights of others. Solomon Systech products are not designed, intended, or authorized for use as components in systems intended for surgical implant into the body, or other applications intended to support or sustain life, or for any other application in which the failure of the Solomon Systech product could create a situation where personal injury or death may occur. Should Buyer purchase or use Solomon Systech products for any such unintended or unauthorized application, Buyer shall indemnify and hold Solomon Systech and its offices, employees, subsidiaries, affiliates, and distributors harmless against all claims, costs, damages, and expenses, and reasonable attorney fees arising out of, directly or indirectly, any claim of personal injury or death associated with such unintended or unauthorized use, even if such claim alleges that Solomon Systech was negligent regarding the design or manufacture of the part.

All Solomon Systech Products complied with six (6) hazardous substances limitation requirement per European Union (EU) "Restriction of Hazardous Substance (RoHS) Directive (2002/95/EC)" and China standard "电子信息产品污染控制标识要求 (SJ/T11364-2006)" with control Marking Symbol . Hazardous Substances test report is available upon requested.

<http://www.solomon-systech.com>